



## PRODUCT SPECIFICATION

### MONO LCD MODULE MODEL: G2409A0SBX6G-B2 Ver:1.0

< ◇ > Preliminary Specification

< ◆ > Finally Specification

CUSTOMER'S APPROVAL	
CUSTOMER :	
SIGNATURE:	DATE:

APPROVED BY	PM REVIEWD	PD REVIEWD	PREPARED BY



## Table of Contents

No.	Contents	Page
1.	FEATURES.....	4
2.	MECHANICAL SPECIFICATIONS .....	4
3.	ELECTRICAL SPECIFICATIONS .....	4
4.	TERMINAL FUNCTIONS AND BLOCK DIAGRAM .....	6
5.	TIMING CHARACTERISTICS .....	8
6.	INSTRUCTION SET.....	12
7.	QUALITY SPECIFICATIONS .....	13
8.	RELIABILITY.....	18
9.	HANDLING PRECAUTION. ....	19
10.	OUTLINE DIMENSION .....	20

## 1. FEATURES

The features of LCD are as follows

- \* Display mode : STN /Yellow-Green/Transflective/Positive
- \* IC : UC1608XGBE
- \* Interface Input Data : 8 – Bits,4-Bits,SPI-3,SPI-4
- \* Driving Method : 1/96Duty, 1/11 Bias
- \* Viewing Direction : 6 O'clock
- \* Backlight : LED /Super Y-G
- \*Sample NO :G2409A0SBX6G-B2\_01/20101023

## 2. MECHANICAL SPECIFICATIONS

Item	Specification	Unit
Module Size	107(W) x46.8(H) x 10.3(D)	mm
Number of Dots	240 x 96 Dots	
Viewing Area	100(H) x 35 (V)	mm
Activity Area	95.98(H) x32.62(V)	mm
Dot Size	0.38(H) x 0.32(V)	mm
Dot Pitch	0.4(H) x 0.34(V)	mm

## 3. ELECTRICAL SPECIFICATIONS

### 3-1 ABSOLUTR MAZIMUM RATINGS (Ta = 25 °C)

Item	Symbol	Standard Value			Unit
		Min.	Typ.	Max.	
Supply Voltage For Logic	$V_{DD}-V_{SS}$	-0.3	-	4.0	V
Supply Voltage For LCD Drive	$V_{OP}=V_{LCD}-V_{SS}$	-0.3	-	17	V
Input Voltage	$V_{in}$	-0.4	-	$V_{DD}+0.5$	V
Operating Temp.	$T_{op}$	-20	-	+70	°C
Storage Temp.	$T_{st}$	-30	-	+80	°C

\*. NOTE: The response time will be extremely slow when the operating temperature is around -10°C, and the back ground will become darker at high temperature operating.

**3-2 ELECTRICAL CHARACTERISTICS**

Item		Symbol	Test Condition	Min.	Typ.	Max.	Unit
Logic supply Voltage		$V_{DD}-V_{SS}$	$T_a = 25\text{ }^\circ\text{C}$ $V_{DD}=3V \pm 10\%$	2.7	3	3.3	V
LCD Drive		$V_{OP}=V_{LCD}-V_{SS}$		12.5	12.8	13.1	V
Input Voltage	"H" Level	$V_{IH}$		0.8 $V_{DD}$	-		V
	"L" Level	$V_{IL}$			-	0.2 $V_{DD}$	V
Frame Frequency		$f_{FLM}$		-	75	-	Hz
Current Consumption		$I_{DD}$		-	0.79	-	mA

**3-3. BACKLIGHT3-3-1. Absolute Maximum Ratings**

Item	Symbol	Condition	Min.	Typ.	Max.	Unit
Forward Current	IF	$T_a = 25\text{ }^\circ\text{C}$	-	-	30	mA
Reverse Voltage	VR		-	-	5	V
Power Dissipation	PD		-	-	132	mW

**3-3-2. Electrical-optical Characteristics**

Item	Symbol	Condition	min	Typ	Max	Unit
Forward Voltage	VF	$I_f=30\text{mA}$ $T_a = 25\text{ }^\circ\text{C}$	3.85	4.0	4.3	V
Average Luminous Intensity	$I_v$		17.5	25	-	$\text{cd/m}^2$
Peak emission wavelength	$\lambda_P$		569	572	575	nm

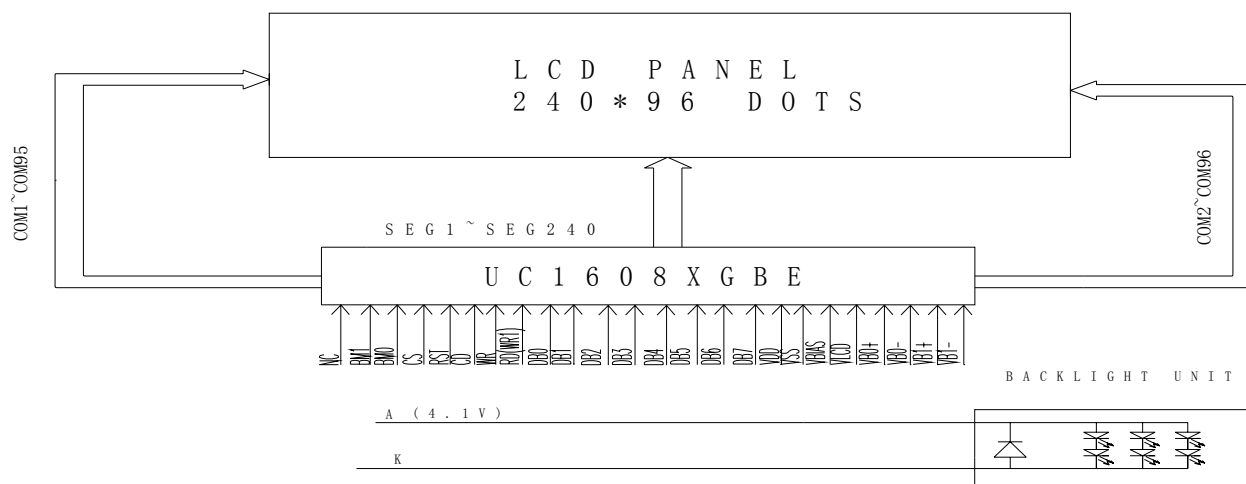
**The brightness is measured without LCD panel**

## 4. TERMINAL FUNCTIONS AND BLOCK DIAGRAM

### 4-1. INTERFACE PIN FUNCTION DESCRIPTION

Pin No.	Pin Name	Function																																											
1-2	VB1-,VB1+ ,	LCD bias voltage																																											
3-4	VB0-,VB0+	LCD bias voltage																																											
5	VLCD	Supply voltage for LCD drive																																											
6	VBIAS	Segment driving voltage																																											
7	VSS	Ground																																											
8	VDD	Supply voltage for logical circuit																																											
9-16	DB7~DB0	Bi-directional bus for both serial and parallel host interfaces. In serial modes, connect D[0] to SCK, D[3] to SDA,																																											
		<table border="1"> <thead> <tr> <th></th> <th>BM=1x (Parallel)</th> <th>BM=0x (Parallel)</th> <th>BM=01 (S9)</th> <th>BM=00 (S8/S8uc)</th> </tr> </thead> <tbody> <tr> <td>D0</td> <td>D0</td> <td>D0/D4</td> <td>SCK</td> <td>SCK</td> </tr> <tr> <td>D1</td> <td>D1</td> <td>D1/D5</td> <td>-</td> <td>-</td> </tr> <tr> <td>D2</td> <td>D2</td> <td>D2/D6</td> <td>-</td> <td>-</td> </tr> <tr> <td>D3</td> <td>D3</td> <td>D3/D7</td> <td>SDA</td> <td>SDA</td> </tr> <tr> <td>D4</td> <td>D4</td> <td>-</td> <td>-</td> <td>-</td> </tr> <tr> <td>D5</td> <td>D5</td> <td>-</td> <td>-</td> <td>-</td> </tr> <tr> <td>D6</td> <td>D6</td> <td>-</td> <td>S9</td> <td>S8/S8uc</td> </tr> <tr> <td>D7</td> <td>D7</td> <td>0</td> <td>1</td> <td>1</td> </tr> </tbody> </table>		BM=1x (Parallel)	BM=0x (Parallel)	BM=01 (S9)	BM=00 (S8/S8uc)	D0	D0	D0/D4	SCK	SCK	D1	D1	D1/D5	-	-	D2	D2	D2/D6	-	-	D3	D3	D3/D7	SDA	SDA	D4	D4	-	-	-	D5	D5	-	-	-	D6	D6	-	S9	S8/S8uc	D7	D7	0
	BM=1x (Parallel)	BM=0x (Parallel)	BM=01 (S9)	BM=00 (S8/S8uc)																																									
D0	D0	D0/D4	SCK	SCK																																									
D1	D1	D1/D5	-	-																																									
D2	D2	D2/D6	-	-																																									
D3	D3	D3/D7	SDA	SDA																																									
D4	D4	-	-	-																																									
D5	D5	-	-	-																																									
D6	D6	-	S9	S8/S8uc																																									
D7	D7	0	1	1																																									
Connect unused pins to V <sub>DD</sub> or V <sub>SS</sub> .																																													
17	RD(WR1)	Read signal or Enable signal																																											
18	WR	Write signal or Write/Read signal select signal																																											
19	CD	Select the command is instruction or data																																											
20	RST	Reset signal																																											
21	CS	Chip selection																																											
22,23	BM0,BM1	Bus mode																																											
24	NC	No connection																																											

### 4-2. BLOCK DIAGRAM



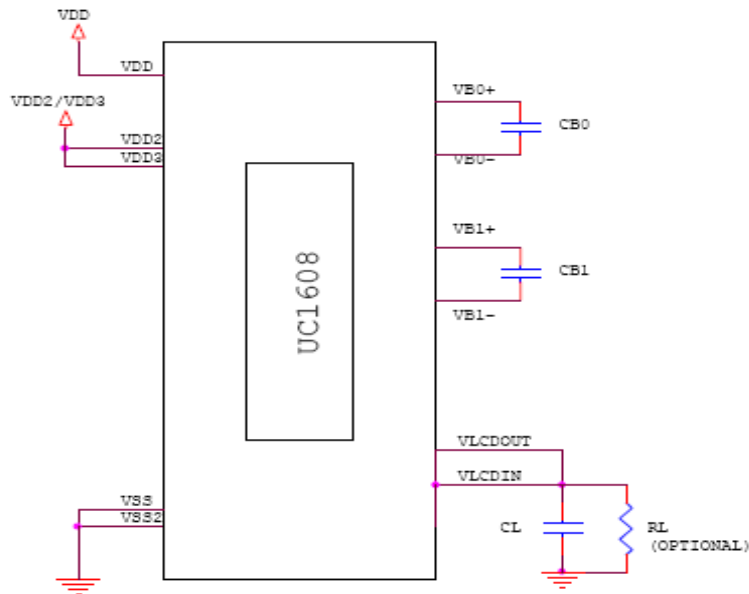
**4-3 High-voltage Mixed-signal IC****HI-V GENERATOR CIRCUIT**

FIGURE 1: Reference circuit using internal Hi-V generator circuit

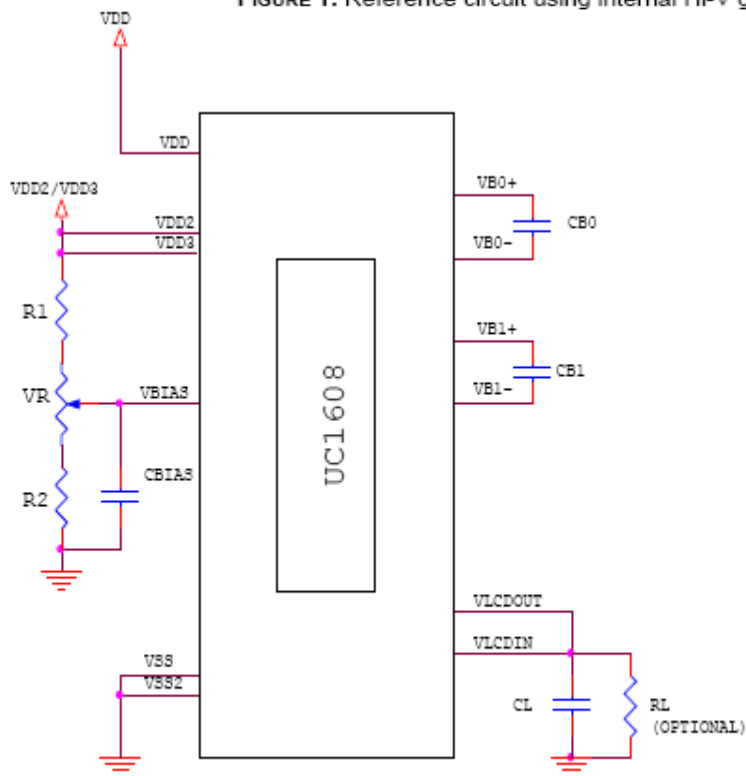


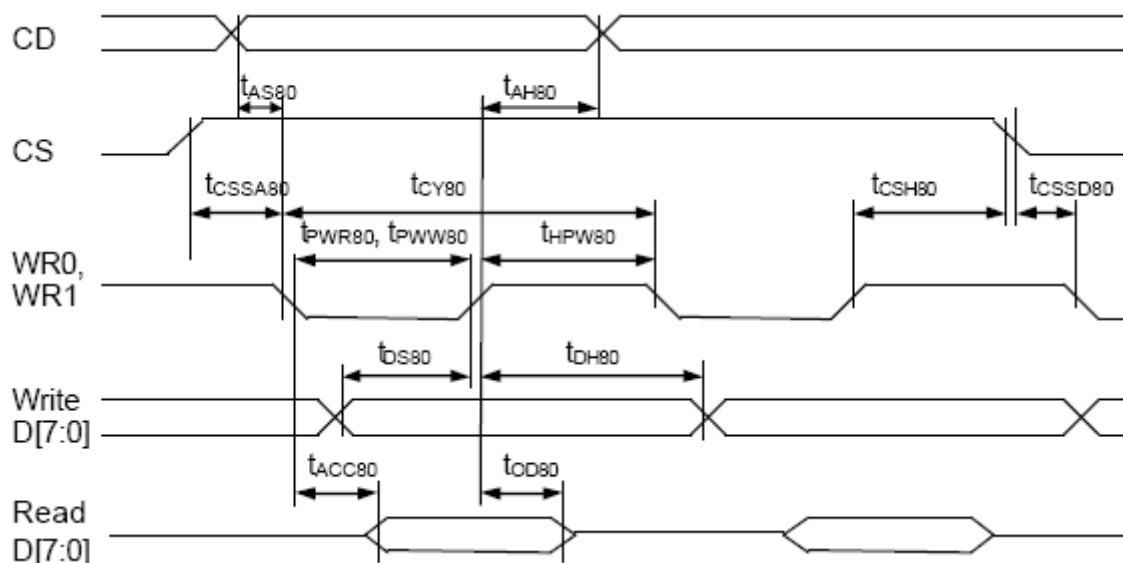
Figure 2: Reference circuit using external Bias source

**Note:**

- Recommended component values:
  - $C_B$ : 150 ~ 250x LCD load capacitance or 4.7 $\mu$ F (2V), whichever is higher.
  - $C_L$ : 50nF ~ 0.1 $\mu$ F (25V) is appropriate for most applications.
  - $R_L$ : 10M $\Omega$ . Acts as a draining circuit when the power is abnormally shut down.
  - $V_R$ : 1M $\Omega$ .
  - $R_1, R_2$ : See instructions below.
  - $C_{BIAS}$ : 10nF ~ 0.1 $\mu$ F is recommended.

## TIMING CHARACTERISTICS

Parallel Bus Timing Characteristics (for 8080 MCU)

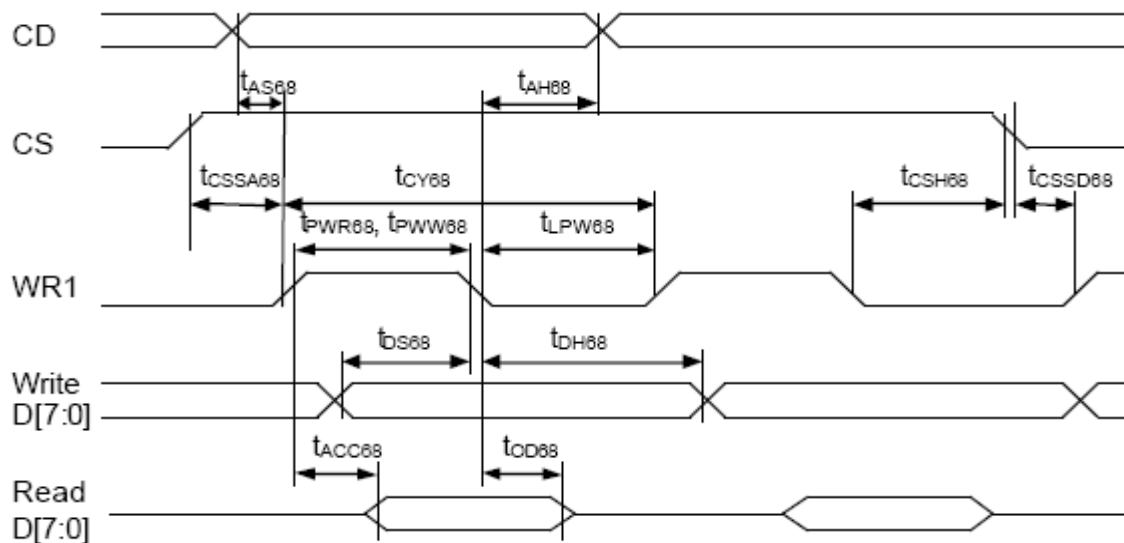


( $2.7V \leq V_{DD} < 3.3V$ ,  $T_a = -30$  to  $+85^\circ C$ )

Symbol	Signal	Description	Condition	Min.	Max.	Units
$t_{AS80}$	CD	Address setup time		0	-	nS
$t_{AH80}$		Address hold time		20	-	nS
$t_{CY80}$		System cycle time				nS
		8 bits bus (read)		140		
		(write)		140		
		4 bits bus (read)		140		
		(write)		140		
$t_{PWR80}$	WR1	Pulse width	8 bits (read)	65	-	nS
			4 bits	65		
$t_{PWW80}$	WR0	Pulse width	8 bits (write)	35	-	nS
			4 bits	35		
$t_{HPW80}$	WR0, WR1	High pulse width				nS
		8 bits bus (read)		65		
		(write)		35		
		4 bits bus (read)		65		
		(write)		35		
$t_{DS80}$	D0~D7	Data setup time		30	-	nS
$t_{DH80}$		Data hold time		20		nS
$t_{ACC80}$		Read access time	$C_L = 100pF$	-	60	nS
$t_{OD80}$		Output disable time		12	20	nS
$t_{SSA80}$	CS1/CS0	Chip select setup time		10		nS
$t_{CSSD80}$				10		
$t_{CSH80}$				20		



## Parallel Bus Timing Characteristics (for 6800 MCU)

(2.7V ≤ V<sub>DD</sub> < 3.3V, T<sub>a</sub> = -30 to +85°C)

Symbol	Signal	Description	Condition	Min.	Max.	Units
t <sub>AS68</sub>	CD	Address setup time		0	–	nS
t <sub>AH68</sub>	CD	Address hold time		20	–	nS
T <sub>CY68</sub>		System cycle time			–	nS
		8 bits bus (read)		140		
		(write)		140		
		4 bits bus (read)		140		
		(write)		140		
t <sub>PWR68</sub>	WR1	Pulse width 8 bits (read)		65		
		4 bits		65	–	nS
t <sub>PWW68</sub>		Pulse width 8 bits (write)		35	–	nS
		4 bits		35	–	nS
t <sub>LPW68</sub>		Low pulse width			–	nS
		8 bits bus (read)		65		
		(write)		35		
		4 bits bus (read)		65		
		(write)		35		
t <sub>DS68</sub>	D0~D7	Data setup time		30	–	nS
t <sub>DH68</sub>	D0~D7	Data hold time		20	–	nS
t <sub>ACC68</sub>		Read access time	C <sub>L</sub> = 100pF	–	60	nS
t <sub>OD68</sub>		Output disable time		12	20	nS
t <sub>CSSA68</sub>	CS1/CS0	Chip select setup time		10		nS
t <sub>CSSD68</sub>	CS1/CS0	Chip select setup time		10		nS
t <sub>CSH68</sub>	CS1/CS0	Chip select setup time		20		nS

## Parallel Bus Timing Characteristics (for SPI-4)

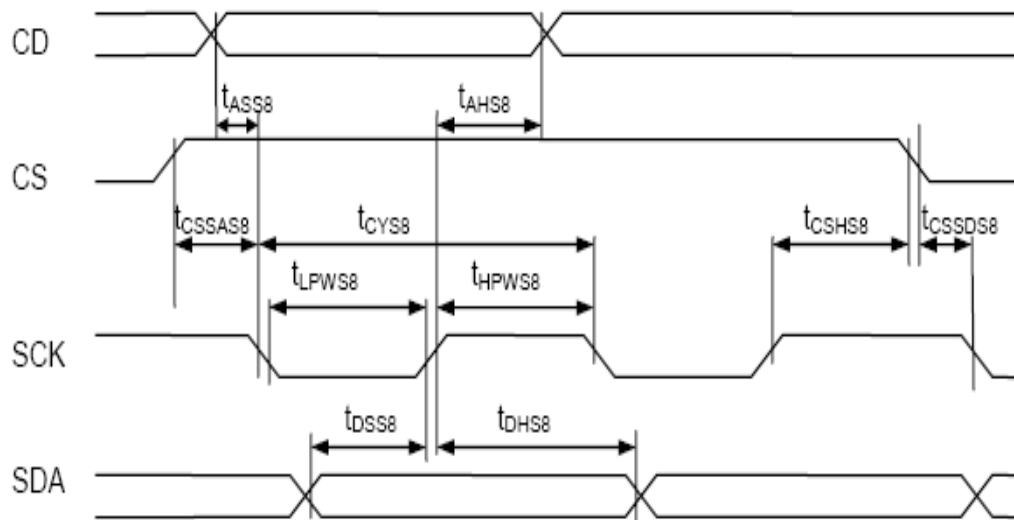


FIGURE 17: Serial Bus Timing Characteristics (for S8)

( $2.7V \leq V_{DD} < 3.3V$ ,  $T_a = -30$  to  $+85^\circ C$ )

Symbol	Signal	Description	Condition	Min.	Max.	Units
$t_{ASS8}$	CD	Address setup time		0	-	nS
$t_{AHS8}$		Address hold time		20	-	nS
$t_{CYS8}$	SCK	System cycle time		140	-	nS
$t_{LPWS8}$		Low pulse width		65	-	nS
$t_{HPWS8}$		High pulse width		65	-	nS
$t_{DSS8}$	SDA	Data setup time		30	-	nS
$t_{DHS8}$		Data hold time		20	-	nS
$t_{CSSAS8}$	CS	Chip select setup time		10		nS
$t_{CSSDS8}$				20		
$t_{CSHS8}$				10		

## Parallel Bus Timing Characteristics (for SPI-3)

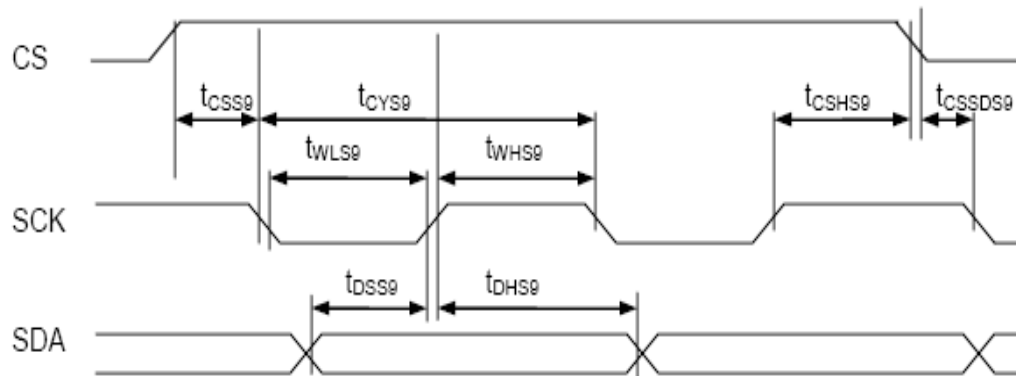
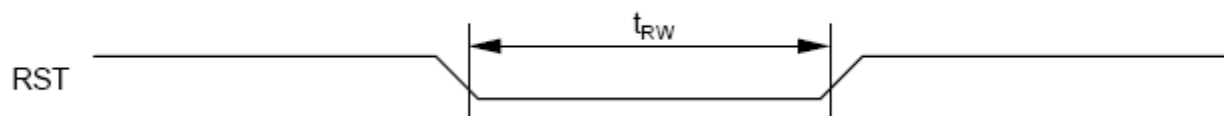


FIGURE 18: Serial Bus Timing Characteristics (for S9)

(2.7V  $\leq$  V<sub>DD</sub> < 3.3V, T<sub>a</sub> = -30 to +85°C)

Symbol	Signal	Description	Condition	Min.	Max.	Units
t <sub>CYS9</sub>	SCK	System cycle time		140	-	nS
t <sub>LPWS9</sub>		Low pulse width		65	-	nS
t <sub>HPWS9</sub>		High pulse width		65	-	nS
t <sub>DSS9</sub>	SDA	Data setup time		30	-	nS
t <sub>DHS9</sub>		Data hold time		20	-	nS
t <sub>CSSAS9</sub>	CS	Chip select setup time		10		nS
t <sub>CSSDS9</sub>				20		
t <sub>CSHS9</sub>				10		

## Reset timing

(2.7V  $\leq$  V<sub>DD</sub> < 3.3V, T<sub>a</sub> = -30 to +85°C)

Symbol	Signal	Description	Condition	Min.	Max.	Units
t <sub>RW</sub>	RST	Reset low pulse width		1000	-	nS

## 5. INSTRUCTION SET

The following is a list of host commands supported by UC1608

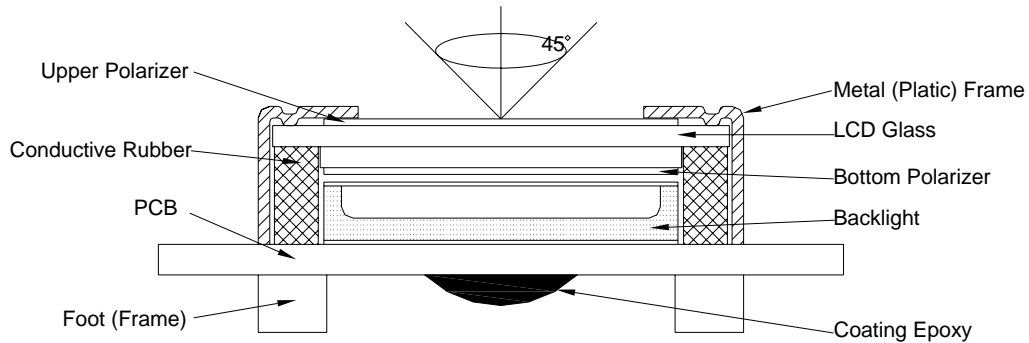
C/D: 0: Control, 1: Data  
 W/R: 0: Write Cycle, 1: Read Cycle  
 # Useful Data bits  
 - Don't Care

	Command	C/D	W/R	D7	D6	D5	D4	D3	D2	D1	D0	Action	Default
1	Write Data Byte	1	0	#	#	#	#	#	#	#	#	Write 1 byte	N/A
2	Read Data Byte	1	1	#	#	#	#	#	#	#	#	Read 1 byte	N/A
3	Get Status	0	1	BZ	MX	DE	RS	WA	GN1	GN0	1	Get Status	N/A
4	Set Column Address LSB	0	0	0	0	0	0	#	#	#	#	Set CA[3:0]	0
	Set Column Address MSB	0	0	0	0	0	1	#	#	#	#	Set CA[7:4]	0
5	Set Mux Rate and temperature compensation.	0	0	0	0	1	0	0	#	#	#	Set {MR, TC[1:0]}	MR: 1b TC: 00b
6	Set Power Control	0	0	0	0	1	0	1	#	#	#	Set PC[2:0]	101b
7	Set Adv. Program Control. (double byte command)	0	0	0	0	1	1	0	0	0	R	For UltraChip only. Do not use.	N/A
		0	0	#	#	#	#	#	#	#	#		
8	Set Start Line	0	0	0	1	#	#	#	#	#	#	Set SL[5:0]	0
9	Set Gain and Potentiometer (double-byte command)	0	0	1	0	0	0	0	0	0	1	Set {GN[1:0], PM[5:0]}	GN=3 PM=0
		0	0	#	#	#	#	#	#	#	#		
10	Set RAM Address Control	0	0	1	0	0	0	1	#	#	#	Set AC[2:0]	001b
11	Set All-Pixel-ON	0	0	1	0	1	0	0	1	0	#	Set DC[1]	0=disable
12	Set Inverse Display	0	0	1	0	1	0	0	1	1	#	Set DC[0]	0=disable
13	Set Display Enable	0	0	1	0	1	0	1	1	1	#	Set DC[2]	0=disable
14	Set Fixed Lines	0	0	1	0	0	1	#	#	#	#	Set FL[3:0]	0
15	Set Page Address	0	0	1	0	1	1	#	#	#	#	Set PA[3:0]	0
16	Set LCD Mapping Control	0	0	1	1	0	0	#	#	#	#	Set LC[3:0]	0
17	System Reset	0	0	1	1	1	0	0	0	1	0	System Reset	N/A
18	NOP	0	0	1	1	1	0	0	0	1	1	No operation	N/A
19	Set LCD Bias Ratio	0	0	1	1	1	0	1	0	#	#	Set BR[1:0]	10b=12
20	Reset Cursor Mode	0	0	1	1	1	0	1	1	1	0	AC[3]=0, CA=CR	N/A
21	Set Cursor Mode	0	0	1	1	1	0	1	1	1	1	AC[3]=1, CR=CA	N/A
22	Set Test Control (double byte command)	0	0	1	1	1	0	0	1	TT		For UltraChip only. Do not use.	N/A
		0	0	#	#	#	#	#	#	#	#		

## 7. QUALITY SPECIFICATIONS

### 7 - 1. LCM Appearance and Electric inspection Condition

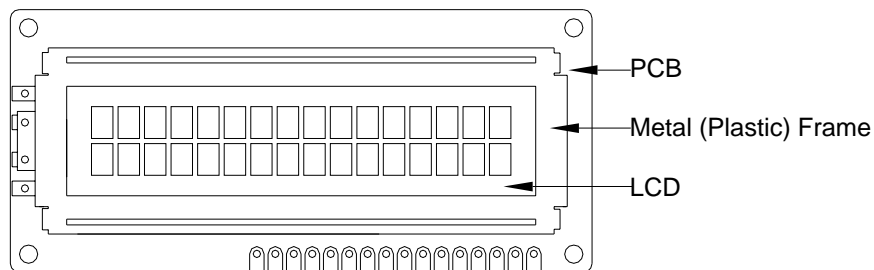
1. Inspection will be done by placing LCM 30cm away from inspector's eyeballs under normal illumination.



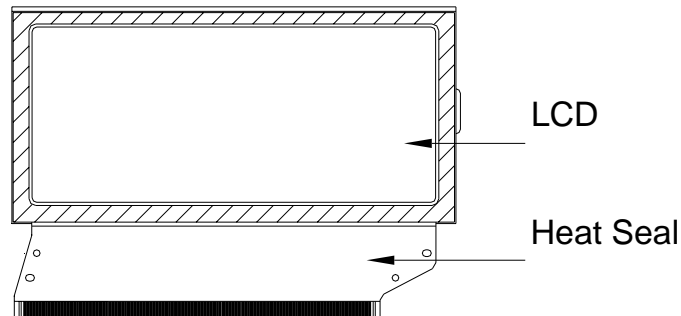
2. View Angle: with in 45° around perpendicular line.

### 7 - 2. Definition

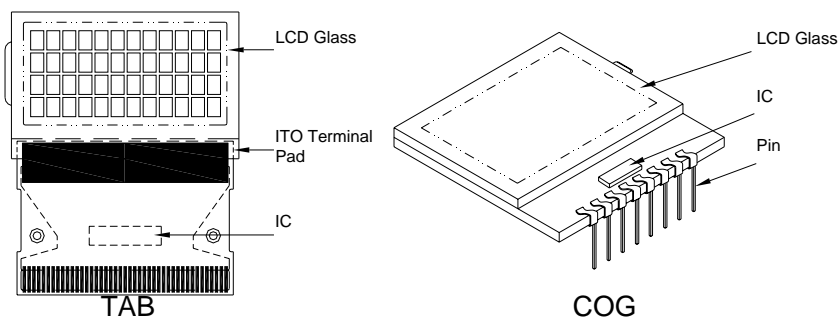
#### 1. COB



#### 2. Heat Seal



#### 3. TAB and COG



**7-3. Sampling Plan and Acceptance**

## 1. Sampling Plan

MIL - STD - 105E ( || ) ordinary single inspection is used.

## 2. Acceptance

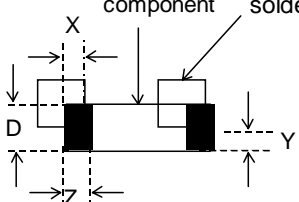
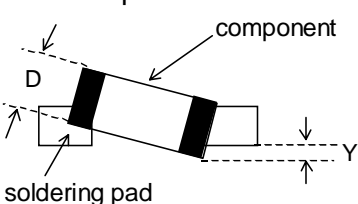
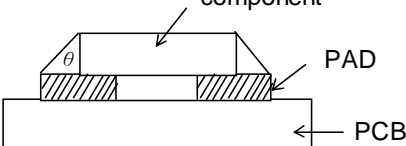
Major defect: AQL = 0.25%

Minor defect: AQL = 0.65%

**7-4. Criteria****1. COB**

Defect	Inspection Item	Inspection Standards	
Major	PCB copper flakes peeling off	Any copper flake in viewing Area should be greater than 1.0mm <sup>2</sup>	Reject
Major	Height of coating epoxy	Exceed the dimension of drawing	Reject
Major	Void or hole of coating epoxy	Expose bonding wire or IC	Reject
Major	PCB cutting defect	Exceed the dimension of drawing	Reject

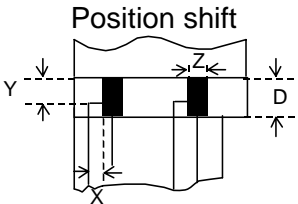
**2. SMT**

Defect	Inspection Item	Inspection Standards	
Minor	Component marking not readable		Reject
Minor	Component height	Exceed the dimension Of drawing	Reject
Major	Component solder defect (missing , extra, wrong component or wrong orientation)		Reject
Minor	Component position shift 	$X < 3/4Z$ $Y > 1/3D$	Reject Reject
Minor	Component tilt 	$Y > 1/3D$	Reject
Minor	Insufficient solder 	$\theta \leq 20^\circ$	Reject

**3. Metal (Plastic) Frame**

Defect	Inspection Item	Inspection Standards		
Major	Crack / breakage	Anywhere		
			Reject	
Minor	Frame Scratch	W	L	Acceptable of Scratch
		$w < 0.1\text{mm}$	Any	Ignore
		$0.1 \leq w < 0.2\text{mm}$	$L \leq 5.0\text{mm}$	2
		$0.2 \leq w < 0.3\text{mm}$	$L \leq 3.0\text{mm}$	1
		$w \geq 0.3\text{mm}$	Any	0
		Note : 1. Above criteria applicable to scratch lines with distance greater than 5mm. 2. Scratch on the back side of frame (not visible) can be ignored .		
Minor	Frame Dent , Prick $\Phi = \frac{L + W}{2}$			Acceptable of Dents / Pricks
		$\Phi \leq 1.0\text{mm}$		2
		$1.0 < \Phi \leq 1.5\text{mm}$		1
		$1.5\text{mm} < \Phi$		0
		Note : 1. Above criteria applicable to any two dents / pricks with distance greater than 5mm 2. Dent / prick on the back side of frame (not visible) can be ignored		
Minor	Frame Deformation	Exceed the dimension of drawing		
Minor	Metal Frame Oxidation	Any rust		

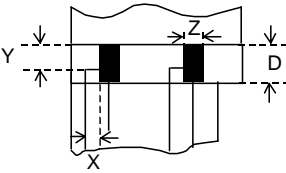
**4. Flexible Film Connector (FFC)**

Defect	Inspection Item	Inspection Standards	
Minor	Tilted soldering	Within the angle $+5^\circ$	Acceptable
Minor	Uneven solder joint /bump		Reject
Minor	Hole $\Phi = \frac{L + W}{2}$	Expose the conductive line	Reject
		$\Phi > 1.0\text{mm}$	Reject
Minor		$Y > 1/3D$	Reject
		$X > 1/2Z$	Reject

**5. Screw**

Defect	Inspection Item	Inspection Standards	
Major	Screw missing/loosen		Reject
Minor	Screw oxidation	Any rust	Reject
Minor	Screw deformation	Difficult to accept screw driver	Reject

**6. Heatseal 、TCP 、FPC**

Defect	Inspection Item	Inspection Standards	
Major	Scratch expose conductive layer		Reject
Minor	HS Hole $\Phi = \frac{L + W}{2}$	$\Phi > 0.5\text{mm}$	Reject
Major	Adhesion strength	Less than the specification	Reject
Minor	Position shift 	$Y > 1/3D$	Reject
		$X > 1/2Z$	Reject
Major	Conductive line break		Reject

**7. LED Backing Protective Film and Others**

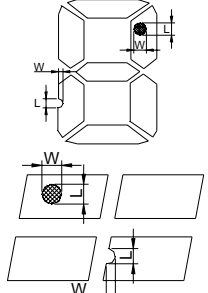
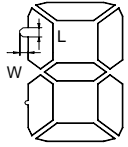
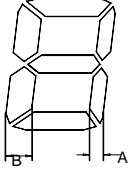
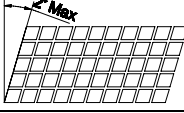
Defect	Inspection Item	Inspection Standards	
Minor	LED dirty, prick	Acceptable number of units	
		$\Phi \leq 0.10\text{mm}$	Ignore
		$0.10 < \Phi \leq 0.15\text{mm}$	2
		$0.15 < \Phi \leq 0.2\text{mm}$	1
		$\Phi > 0.2\text{mm}$	0
The distance between any two spots should be $\geq 5\text{mm}$ Any spot/dot/void outside of viewing area is acceptable			
Minor	Protective film tilt	Not fully cover LCD	Reject
Major	COG coating	Not fully cover ITO circuit	Reject

**8. Electric Inspection**

Defect	Inspection Item	Inspection Standards	
Major	Short		Reject
Major	Open		Reject



## 9. Inspection Specification of LCD

Defect	Inspect Item	Inspection Standards				
Minor	Linear Defect * Glass Scratch * Polarizer Scratch * Fiber and Linear material	W	$W \leq 0.03$	$0.03 < W \leq 0.05$	$W > 0.05$	
		L	$L < 5$	$L < 3$	Any	
		ACC. NO.	1	1	Reject	
		Note	L is the length and W is the width of the defect			
Minor	Black Spot and Polarizer Pricked * Foreign material between glass and polarizer or glass and glass * Polarizer hole or protuberance by external force	$\Phi$	$\Phi \leq 0.1$	$0.1 < \Phi \leq 0.15$	$0.15 < \Phi \leq 0.2$	$\Phi > 0.2$
		ACC. NO.	3EA / 100mm <sup>2</sup>	2	1	0
		Note	$\Phi$ is the average diameter of the defect. Distance between two defects > 10mm.			
Minor	White Spot and Bubble in polarizer * Unobvious transparent foreign material between glass and glass or glass and polarizer * Air protuberance between polarizer and glass	$\Phi$	$\Phi \leq 0.3$	$0.3 < \Phi \leq 0.5$	$0.5 < \Phi$	
		ACC. NO.	3EA / 100mm <sup>2</sup>	1	0	
		Note	$\Phi$ is the average diameter of the defect. Distance between two defects > 10mm.			
Minor	Segment Defect 	$\Phi$	$\Phi \leq 0.10$	$0.10 < \Phi \leq 0.20$	$0.20 < \Phi \leq 0.25$	$\Phi > 0.25$
		ACC. NO.	3EA / 100mm <sup>2</sup>	2	1	0
		Note	W is more than 1/2 segment width			Reject
		Note	$\Phi = \frac{L + W}{2}$ Distance between two defect is 10mm			
Minor	Protuberant Segment  $\Phi = (L + W) / 2$	$\Phi$	$\Phi \leq 0.10$	$0.10 < \Phi \leq 0.20$	$0.20 < \Phi \leq 0.25$	$\Phi > 0.25$
		W	Glue	$W \leq 1/2$ Seg $W \leq 0.2$	$W \leq 1/2$ Seg $W \leq 0.2$	Ignore
		ACC. NO.	3EA / 100mm <sup>2</sup>	2	1	0
Minor	Assembly Mis-alignment  	1. Segment				
		B	$B \leq 0.4\text{mm}$	$0.4 < B \leq 1.0\text{mm}$	$B > 1.0\text{mm}$	
		B-A	$B-A < 1/2B$	$B-A < 0.2$	$B-A < 0.25$	
		Judge	Acceptable	Acceptable	Acceptable	
		2. Dot Matrix				
Deformation > 2°				Reject		
Minor	Stain on LCD Panel Surface	Accept when stains can be wiped lightly with a soft cloth or a similar one. Otherwise, judged according to the above items: "Black spot" and "White Spot"				

**8. RELIABILITY**

NO.	Item	Condition	Criterion
1	High Temperature Operating	70°C , 96Hrs	No defect in cosmetic and operational function allowable. Total current Consumption should be below double of initial value.
2	Low Temperature Operating	-20°C , 96Hrs	
3	High Humidity	60°C , 90%RH, 96Hrs	
4	High Temperature Storage	80°C , 96Hrs	
5	Low Temperature Storage	-30°C , 96Hrs	
6	Vibration	Random wave 10 ~ 100Hz Acceleration: 2g 2 Hrs per direction(X,Y,Z)	
7	Thermal Shock	-20°C to 25°C to 70°C (60Min) (5Min) (60Min) 16Cycles	
8	ESD Testing	Contract Discharge Voltage: +1 ~ 5kV and -1 ~ -5kV  Air Discharge Voltage: +1 ~ 8kV and -1 ~ -8kV	There will be discharged ten times at every discharging voltage cycle. The voltage gap is 1kV.

Note: 1) Above conditions are suitable for our company standard products.

2) For restrict products, the test conditions listed as above must be revised.

## 9. HANDLING PRECAUTION

### (1) Mounting Method

The panel of the LCD Module consists of two thin glass plates with polarizers which easily get damaged since the Module is fixed by utilizing fitting holes in the printed circuit board. Extreme care should be taken when handling the LCD Modules.

### (2) Caution of LCD handling & cleaning

When cleaning the display surface, use soft cloth with solvent (recommended below) and wipe lightly.

- Isopropyl alcohol
- Ethyl alcohol
- Trichloro trifluro thane

Do not wipe the display surface with dry or hard materials that will damage the polarizer surface.

Do not use the following solvent:

- Water
- Ketone
- Aromatics

### (3) Caution against static charge

The LCD Module use C-MOS LSI drivers, so we recommend that you connect any unused input terminal to VDD or VSS, do not input any signals before power is turned on. And ground your body, Work/assembly table. And assembly equipment to protect against static electricity.

### (4) Packaging

- Modules use LCD elements, and must be treated as such. Avoid intense shock and falls from a height.
- To prevent modules from degradation. Do not operate or store them exposed directly to sunshine or high temperature/humidity.

### (5) Caution for operation

- It is indispensable to drive LCD's within the specified voltage limit since the higher voltage than the limit shorten LCD life. An electrochemical reaction due to direct current causes LCD deterioration, Avoid the use of direct current drive.
- Response time will be extremely delayed at lower temperature than the operating temperature range and on the other hand at higher temperature LCD's show dark color in them. However those phenomena do not mean malfunction or out of order with LCD's. Which will come back in the specified operating temperature range.
- If the display area is pushed hard during operation, some font will be abnormally displayed but it resumes normal condition after turning off once.
- A slight dew depositing on terminals is a cause for electro-chemical reaction resulting in terminal open circuit.

Usage under the relative condition of 40°C, 50%RH or less is reequired.

### (6) Storage

In the case of storing for a long period of time (for instance.) For years) for the purpose or replacement use, The following ways are recommended.

- Storage in a polyethylene bag with sealed so as not to enter fresh air outside in it, And with no desiccant.
- Placing in a dark place where neither exposure to direct sunlight nor light is. Keeping temperature in the specified storage temperature range.
- Storing with no touch on polarizer surface by the anything else. (It is recommended to store them as they have been contained in the inner container at the time of delivery)

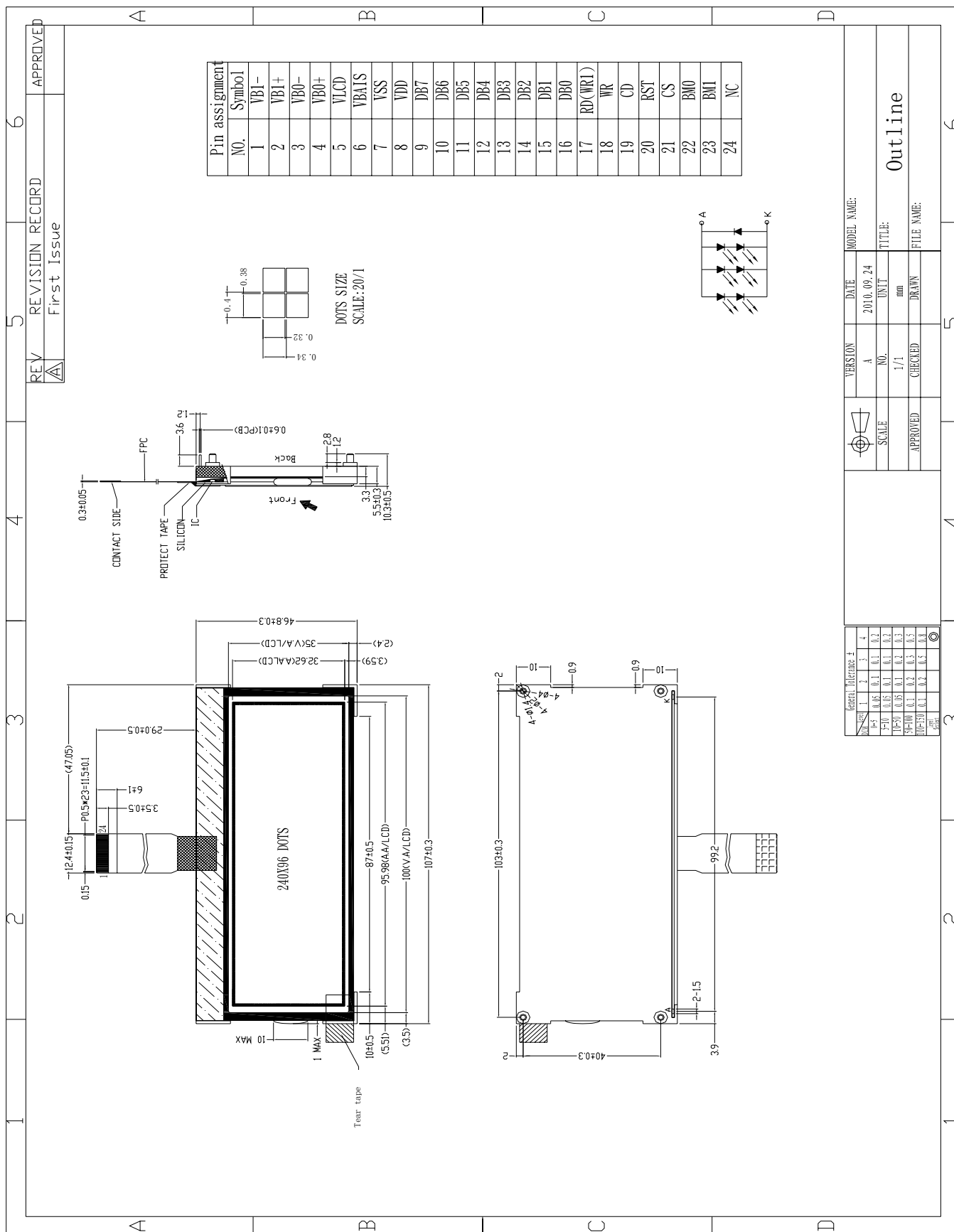
### (7) Safety

- It is recommendable to crash damaged or unnecessary LCD into pieces and wash off liquid crystal by using solvents such as acetone and ethanol.

Which should be burned up later.

When any liquid crystal leaked out of a damaged glass cell comes in contact with your hands, please wash it off well with soap and water.

# 10. OUTLINE DIMENSION



REV	REVISION RECORD	APPROVED
A	First Issue	

VERSION	DATE	MODEL NAME:
A	2010.09.24	

NO.	UNIT	TITLE:
1/1	mm	Outline

CHECKED	DRAWN	FILE NAME:

NO.	INTEGRITY	1	2	3	4
1-5	0.05	0.1	0.1	0.2	0.2
5-10	0.05	0.1	0.1	0.2	0.3
10-20	0.05	0.1	0.2	0.3	0.5
20-50	0.1	0.2	0.3	0.5	0.8
50-100	0.1	0.2	0.5	0.8	1.2