



PRODUCT SPECIFICATION

MONO LCD MODULE MODEL: G1604A0FVW1G-A0 Ver:1.1

< ◇ > Preliminary Specification

< ◆ > Finally Specification

CUSTOMER'S APPROVAL	
CUSTOMER :	
SIGNATURE:	DATE:

APPROVED BY	PM REVIEWED	PD REVIEWED	PREPARED By

Table of Contents

No.	Contents	Page
1.	FEATURES	4
2.	MECHANICAL SPECIFICATIONS	4
3.	ELECTRICAL SPECIFICATIONS.....	4
4.	TERMINAL FUNCTIONS AND BLOCK DIAGRAM	6
5.	TIMING CHARACTERISTICS	8
6.	INSTRUCTION SET	9
7.	QUALITY SPECIFICATIONS.....	15
8.	RELIABILITY	20
9.	HANDLING PRECAUTION.....	21
10.	OUTLINE DIMENSION.....	22

1. FEATURES

The features of LCD are as follows

- * Display mode : FSTN, Negative , Transmissive
- * IC : ST7528
- * Interface Input Data : 4-line serial interface
- * Driving Method : 1/44Duty, 1/7Bias
- * Viewing Direction : 6 O'clock
- * Backlight : LED Unit (White)
- * Sample NO :

2. MECHANICAL SPECIFICATIONS

Item	Specification	Unit
Module Size	85(W) x 32(H) x 4.5MAX(T)	mm
Viewing Area	80(W) x 21(H)	mm
Activity Area	73.58(W) x17.58(H)	mm
Number of Dots	160X44 Dots	-
Dot Size	0.44(W) x 0.38(H)	mm
Dot Pitch	0.46(W) x 0.4(H)	mm

3. ELECTRICAL SPECIFICATIONS

3-1 ABSOLUTR MAZIMUM RATINGS (Ta = 25 °C)

Item	Symbol	Standard Value			Unit
		Min.	Typ.	Max.	
Supply Voltage For Logic	$V_{DD} - V_{SS}$	-0.5	-	3.6	V
Supply Voltage For LCD Drive	$V_{OP} = V_0 - V_{SS}$	3.5	-	15	V
Input Voltage	V_{in}	-0.5	-	$V_{DD} + 0.5$	V
Operating Temp.	T_{op}	-10	-	+60	°C
Storage Temp.	T_{st}	-20	-	+70	°C

*. NOTE: The response time will be extremely slow when the operating temperature is around -20°C, and the back ground will become darker at high temperature operating.

3-2 ELECTRICAL CHARACTERISTICS

Item		Symbol	Test Condition	Min.	Typ.	Max.	Unit
Logic supply Voltage		$V_{DD} - V_{SS}$	$T_a = 25\text{ }^\circ\text{C}$	3.1	3.3	3.5	V
LCD Drive		$V_{OP}=V_0-V_{SS}$		8.5	9.0	9.5	V
Input Voltage	"H" Level	V_{IH}	$V_{DD}=3.3V \pm 5\%$	0.7 V_{DD}	-	V_{DD}	V
	"L" Level	V_{IL}		V_{SS}	-	0.3 V_{DD}	V
Frame Frequency		f_{FLM}	$V_{DD} = 3.3V$	-	77	-	Hz
Current Consumption		I_{DD}	$V_{DD} = 3.3V$	-	0.7	-	mA

3-3. BACKLIGHT**3-3-1. Absolute Maximum Ratings**

Item	Symbol	Condition	Min.	Typ.	Max.	Unit
Forward Current	I_F	$T_a = 25\text{ }^\circ\text{C}$	-	80	90	mA
Reverse Voltage	V_R		-	-	5	V
Power Dissipation	P_D		-	240	-	mW

3-3-2. Electrical-optical Characteristics

Item	Symbol	Condition	Min.		Typ.		Max.		Unit
Forward Voltage	V_F	$I_F=90\text{mA}$ $T_a = 25\text{ }^\circ\text{C}$	2.8		3.0		3.3		V
Average Luminous Intensity	I_v	$I_F=90\text{mA}$ $T_a = 25\text{ }^\circ\text{C}$	-		160		-		cd/m^2
Colour Coordinates	-	$I_F=90\text{mA}$ $T_a = 25\text{ }^\circ\text{C}$	X	Y	X	Y	X	Y	-
			-	-	0.28	0.28	-	-	

The brightness is measured without LCD panel

4. TERMINAL FUNCTIONS AND BLOCK DIAGRAM**4-1. INTERFACE PIN FUNCTION DESCRIPTION**

Pin No.	Pin Name	Function
1-5	V0,V1,V2,V3,V4	LCD Driver Supply Voltage
6	NC	Not use
7	VOUT	DC/DC Voltage converter Connect a capacitor between the VOUT terminal and the VSS terminal
8	VSS	Power Ground
9	VDD	Supply Voltage for Logical circuit(3.3V)
10	SI	Date bus line or serial data input
11	SCL	Date bus line or serial Clock input
12	A0	Register select input pin
13	RST	Reset input pin
14	CSB	Chip Selection input pin

ST7528 I/O PIN ITO Resister Limitation

PIN Name	ITO Resister
PS2,PS1,PS0,REF,OCS1,INTRS,Mode, TA	No Limitation
T0...9 , VR(No used) , VEXT(No used)	Floating
Vdd, Vdd2, Vss, Vss2, VOUT_IN , VOUT_OUT,	<100Ω
VR(used) , VEXT(used)	<500Ω
CSB , E , R/W , A0 , D0 ...D7	<1KΩ
V1 , V2 , V3 , V4	<500Ω
RST	<10KΩ

4-2. BLOCK DIAGRAM

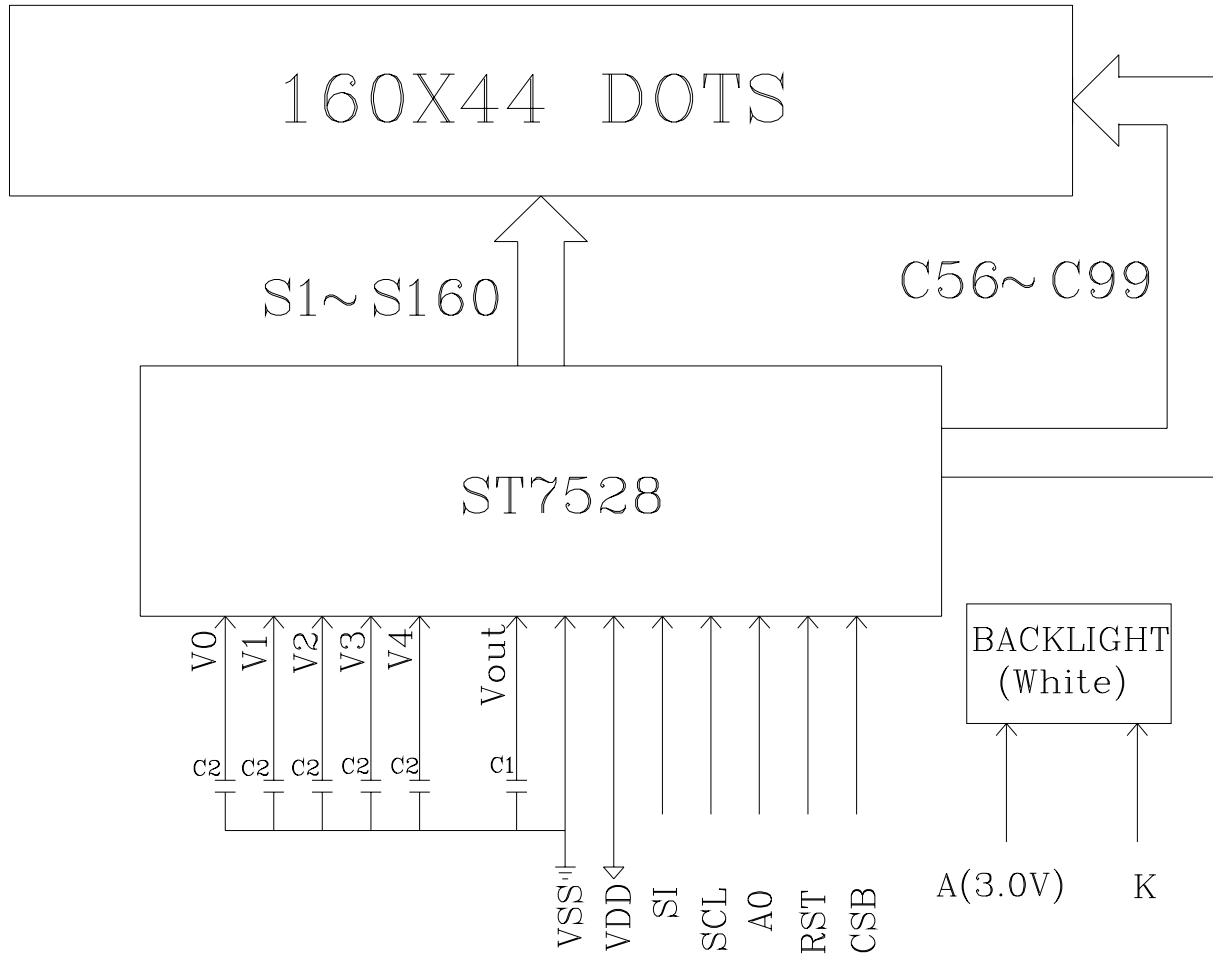

C1=1uF~4.7uF, C2=0.1uF~1uF
Suggestion Value: C1=1uF, C2=0.1uF

4-3. The MPU interface(4-line interface)

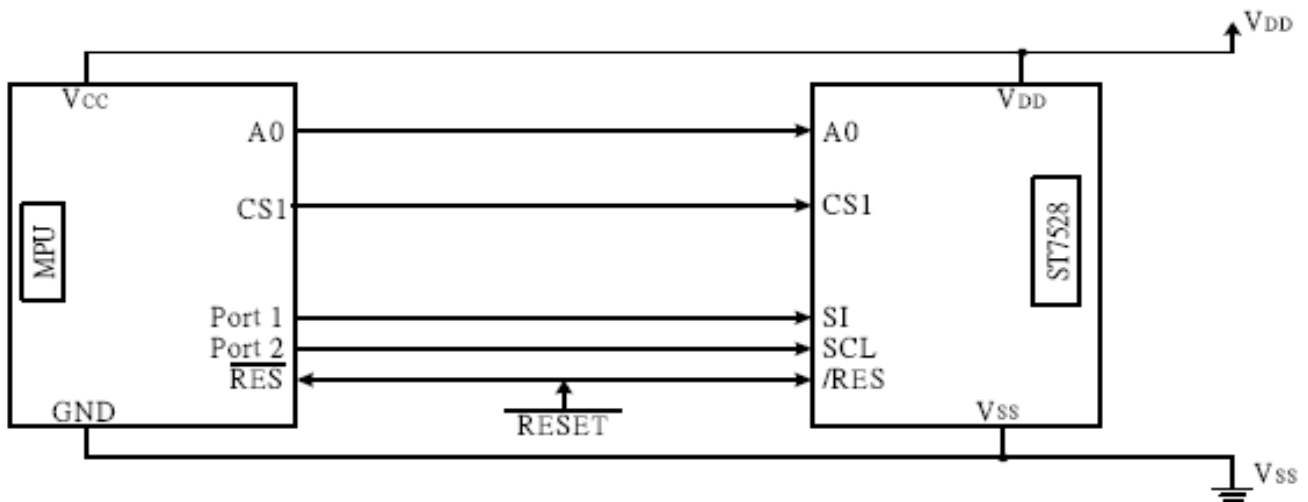

5. TIMING CHARACTERISTICS

5-1 4-line SPI MODE SET(PS0= "L" ,PS1= "H" ,PS2= "L")

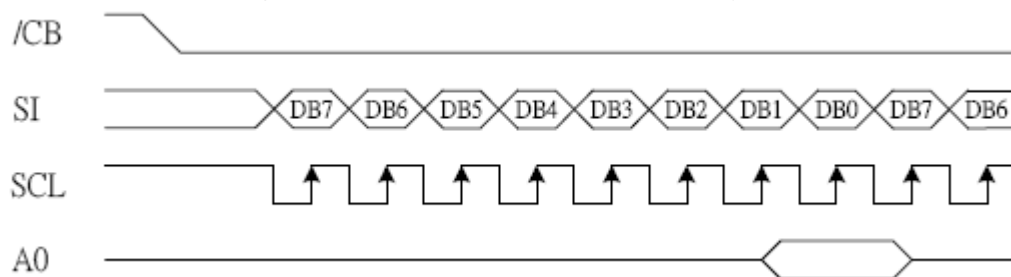

5-2 4-line SPI MODE

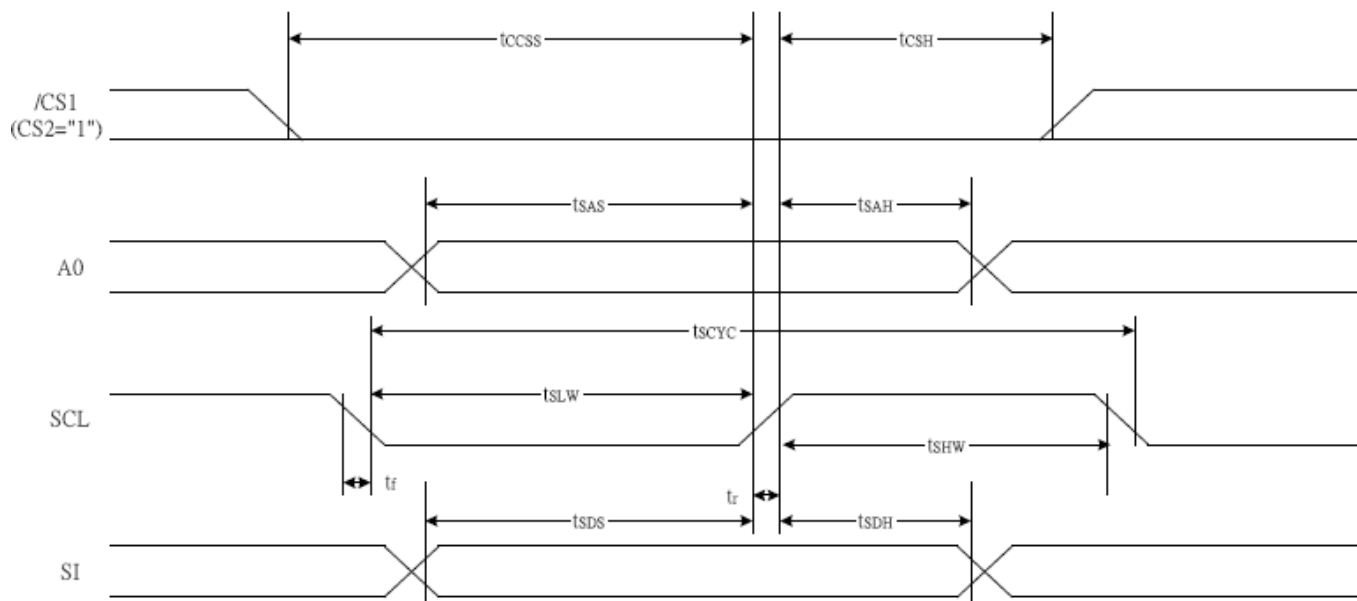

Item	Signal	Symbol	Condition	Rating		Units
				Min.	Max.	
Serial Clock Period	SCL	tSCYC		50	—	ns
SCL "H" pulse width		tSHW		25	—	
SCL "L" pulse width		tSLW		25	—	
Address setup time	A0	tSAS		20	—	
Address hold time		tSAH		10	—	
Data setup time	SI	tSDS		20	—	
Data hold time		tSDH		10	—	
CS-SCL time	CSB	tCSS		20	—	
CS-SCL time		tCSH		40	—	

*1 The input signal rise and fall time (t_r , t_f) are specified at 15 ns or less.

*2 All timing is specified using 20% and 80% of VDD as the standard.

6. INSTRUCTION SET

Instruction	A0	RW	DB7	DB6	DB5	DB4	DB3	DB2	DB1	DB0	Description
EXT=0 or 1											
Mode Set	0	0	0	0	1	1	1	0	0	0	2-byte instruction to set Mode and
	0	0	FR3	FR2	FR1	FR0	0	BE	x'	EXT	FR(Frame frequency control) BE(Booster efficiency control)
EXT=0											
Read display data	1	1	Read data							Read data into DDRAM	
Write display data	1	0	Write data							Write data into DDRAM	
Read status	0	1	BUSY	ON	RES	MF2	MF1	MF0	DS1	DS0	Read the internal status
ICON control register ON/OFF	0	0	1	0	1	0	0	0	1	ICON	ICON=0: ICON disable(default) ICON=1: ICON enable & set the page address to 16
Set page address	0	0	1	0	1	1	P3	P2	P1	P0	Set page address
Set column address MSB	0	0	0	0	0	1	Y9	Y8	Y7	Y6	Set column address MSB
Set column address LSB	0	0	0	0	0	0	Y5	Y4	Y3	Y2	Set column address LSB
Set modify-read	0	0	1	1	1	0	0	0	0	0	Set modify-read mode
Reset modify-read	0	0	1	1	1	0	1	1	1	0	release modify-read mode
Display ON/OFF	0	0	1	0	1	0	1	1	1	D	D=0: Display OFF D=1: Display ON
Set initial display line register	0	0	0	1	0	0	0	0	x'	x'	2-byte instruction to specify the initial display line to realize vertical scrolling
	0	0	x'	S6	S5	S4	S3	S2	S1	S0	
Set initial COM0 register	0	0	0	1	0	0	0	1	x'	x'	2-byte instruction to specify the initial COM0 to realize window scrolling
	0	0	x'	C6	C5	C4	C3	C2	C1	C0	
Select partial display line	0	0	0	1	0	0	1	0	x'	x'	2-byte instruction to set partial display ratio
	0	0	D7	D6	D5	D4	D3	D2	D1	D0	
Set N-line inversion	0	0	0	1	0	0	1	1	x'	x'	2-byte instruction to set N-line inversion register
	0	0	x'	x'	x'	N4	N3	N2	N1	N0	
Release N-line inversion	0	0	1	1	1	0	0	1	0	0	Release N-line inversion mode
Reverse display ON/OFF	0	0	1	0	1	0	0	1	1	REV	REV=0: normal display REV=1: reverse display
Entire display ON/OFF	0	0	1	0	1	0	0	1	0	EON	EON=0: normal display EON=1: entire display ON

Instruction	A0	RW	DB7	DB6	DB5	DB4	DB3	DB2	DB1	DB0	Description
Ext=0											
Power control	0	0	0	0	1	0	1	VC	VR	VF	Control power circuit operation
Select DC-DC step-up	0	0	0	1	1	0	0	1	DC1	DC0	Select the step-up of internal voltage converter
Select regulator register	0	0	0	0	1	0	0	R2	R1	R0	Select the internal resistance ratio of the regulator resistor
Select electronic volumn register	0	0	1	0	0	0	0	0	0	1	2-byte instruction to specify the reference voltage
	0	0	x'	x'	EV5	EV4	EV3	EV2	EV1	EV0	
Select LCD bias	0	0	0	1	0	1	0	B2	B1	B0	Select LCD bias
Set Bias Power Save Mode	0	0	1	1	1	1	0	0	1	1	Bias Power save Save the Bias current consumption
	0	0	0	0	0	0	0	0	0	0	
Release Bias Power Save Mode	0	0	1	1	1	1	0	0	1	1	Bias Power save release set the Bias power to normal
	0	0	0	0	0	0	0	1	0	0	
SHL select	0	0	1	1	0	0	SHL	x'	x'	x'	COM bi-directional selection SHL=0: normal direction SHL=1: reverse direction
ADC select	0	0	1	0	1	0	0	0	0	ADC	SEG bi-direction selection ADC=0: normal direction ADC=1: reverse direction
Oscillator on start	0	0	1	0	1	0	1	0	1	1	Start the built-in oscillator
Set power save mode	0	0	1	0	1	0	1	0	0	P	P=0: normal mode P=1: sleep mode
Release power save mode	0	0	1	1	1	0	0	0	0	1	release power save mode
Reset	0	0	1	1	1	0	0	0	1	0	initial the internal function
Set data direction & display data length(DDL)	x'	x'	1	1	1	0	1	0	0	0	2-byte instruction to specify the number of data bytes. (SPI mode)
	x'	x'	D7	D6	D5	D4	D3	D2	D1	D0	
Select FRC and PWM mode	0	0	1	0	0	1	0	FRC	PWM1	PWM0	FRC(1:3FRC, 0:4FRC) PWM1 PWM0 0 0 45PWM 0 1 45 PWM 1 0 60PWM 1 1 ---
NOP	0	0	1	1	1	0	0	0	1	1	<i>No operation</i>
Test Instruction	0	0	1	1	1	1	x'	x'	x'	x'	<i>Don't use this instruction</i>

Instruction	A0	RW	DB7	DB6	DB5	DB4	DB3	DB2	DB1	DB0	Description
EXT=1											
Set white mode and 1 st frame, set pulse width	0	0	1	0	0	0	0	0	0	0	Set white mode and 1st frame
	0	0	X'	X'	GA05	GA04	GA03	GA02	GA01	GA00	
Set white mode and 2 nd frame, set pulse width	0	0	1	0	0	0	0	0	0	1	Set white mode and 2nd frame
	0	0	X'	X'	GA05	GA04	GA03	GA02	GA01	GA00	
Set white mode and 3 rd frame, set pulse width	0	0	1	0	0	0	0	0	1	0	Set white mode and 3rd frame
	0	0	X'	X'	GA05	GA04	GA03	GA02	GA01	GA00	
Set white mode and 4 th frame, set pulse width	0	0	1	0	0	0	0	0	1	1	Set white mode and 4th frame
	0	0	X'	X'	GA05	GA04	GA03	GA02	GA01	GA00	
Set gray level 1 mode	0	0	84H~87H (4 bytes)							Set gray level1	
Set gray level 2 mode	0	0	88H~8BH (4 bytes)							Set gray level2	
Set gray level 3 mode	0	0	8CH~8FH (4bytes)							Set gray level3	
Set gray level 4 mode	0	0	90H~93H (4bytes)							Set gray level4	
Set gray level 5 mode	0	0	94H~97H (4bytes)							Set gray level5	
Set gray level 6 mode	0	0	98H~9BH (4 bytes)							Set gray level6	
Set gray level 7 mode	0	0	9CH~9FH (4 bytes)							Set gray level7	
Set gray level 8 mode	0	0	A0H~A3H (4 bytes)							Set gray level8	
Set gray level 9 mode	0	0	A4H~A7H (4 bytes)							Set gray level9	
Set gray level 10 mode	0	0	A8H~ABH (4 bytes)							Set gray level10	
Set gray level 11mode	0	0	ACH~AFH (4 bytes)							Set gray level11	
Set gray level 12 mode	0	0	B0H~B3H (4 bytes)							Set gray level12	
Set gray level 13 mode	0	0	B4H~B7H (4 bytes)							Set gray level13	
Set gray level 14 mode	0	0	B8H~BBH (4 bytes)							Set gray level14	
Set Dark mode and 1st frame, set pulse width	0	0	1	0	1	1	1	1	0	0	Set Dark mode and 1st frame, set pulse width
	0	0	X'	X'	GAF5	GAF4	GAF3	GAF2	GAF1	GAF0	
Set Dark mode and 2nd frame, set pulse width	0	0	1	0	1	1	1	1	0	1	Set Dark mode and 2nd frame, set pulse width
	0	0	X'	X'	GAF5	GAF4	GAF3	GAF2	GAF1	GAF0	
Set Dark mode and 3rd frame, set pulse width	0	0	1	0	1	1	1	1	1	0	Set Dark mode and 3rd frame, set pulse width
	0	0	X'	X'	GAF5	GAF4	GAF3	GAF2	GAF1	GAF0	
Set Dark mode and 4th frame, set pulse width	0	0	1	0	1	1	1	1	1	1	Set Dark mode and 4th frame, set pulse width
	0	0	X'	X'	GAF5	GAF4	GAF3	GAF2	GAF1	GAF0	

6-2-1 .Referential Instruction Setup Flow: Initializing with the built-inpower Supply Circuits

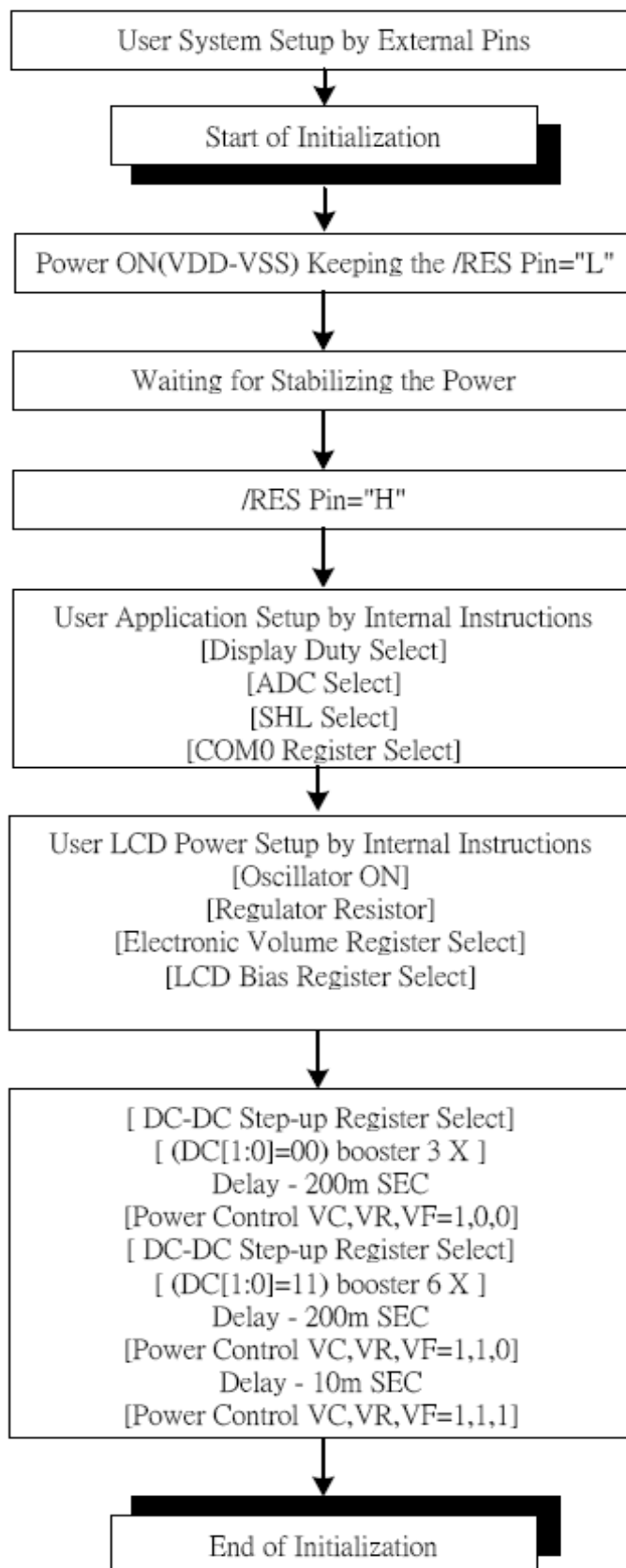

6-2-2 .Referential Instruction Setup Flow: Initializing without the built-inpower Supply Circuits

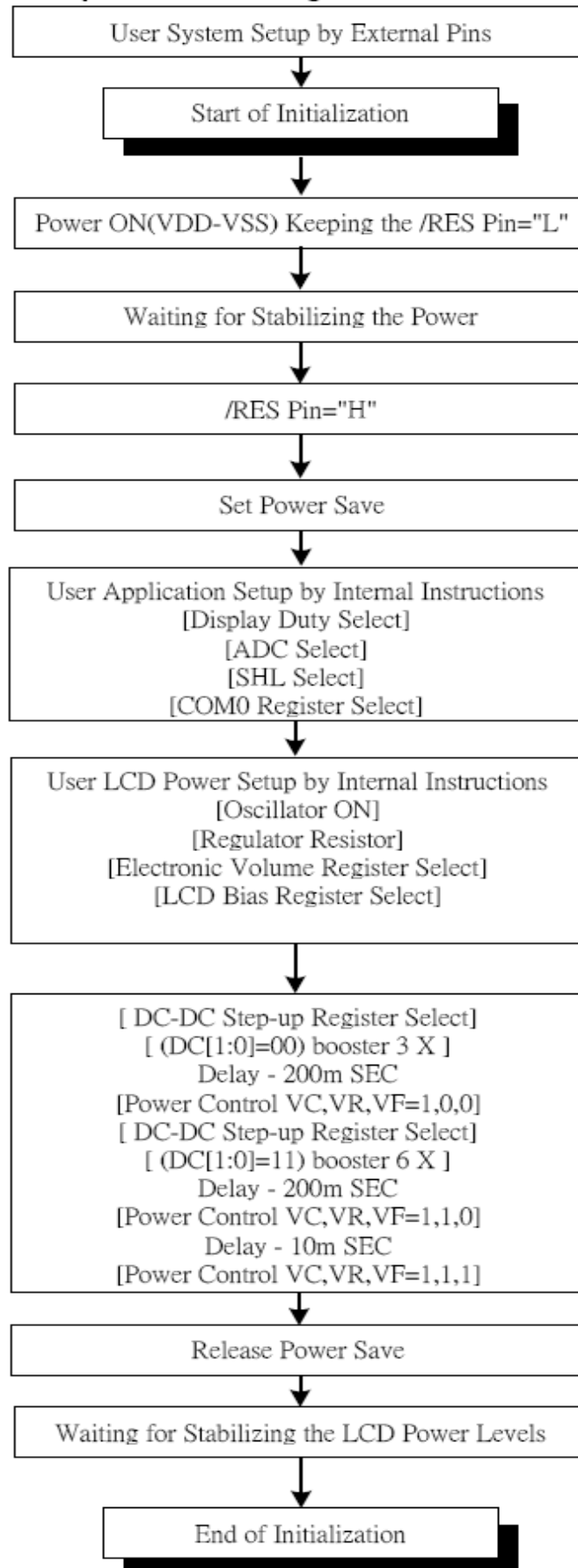

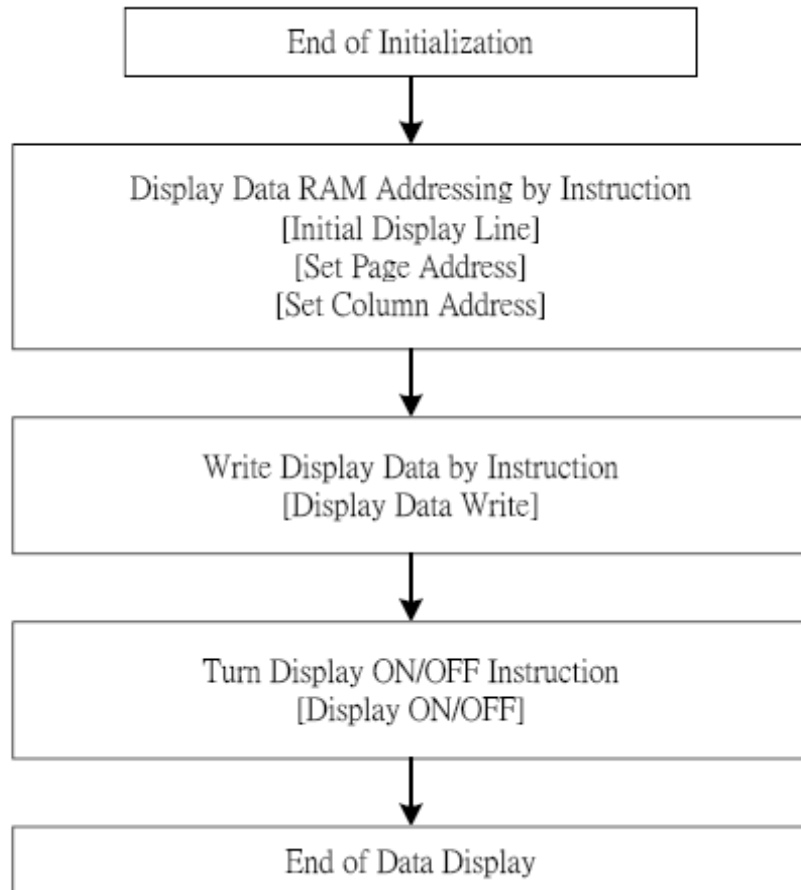
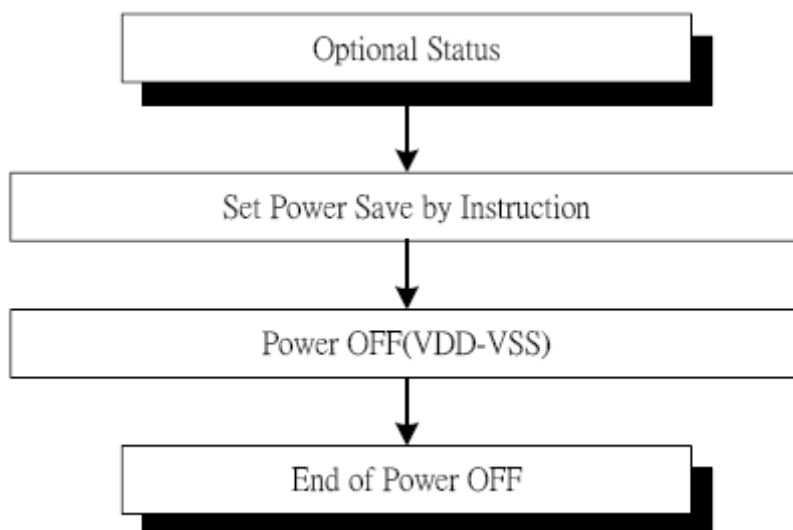
6-3 .Referential Instruction Setup Flow: Date displaying**6-4.Referential Instruction Setup Flow: Power off**

7. QUALITY SPECIFICATIONS

7 - 1. LCM Appearance and Electric inspection Condition

1. Inspection will be done by placing LCM 30cm away from inspector's eyeballs under normal illumination.

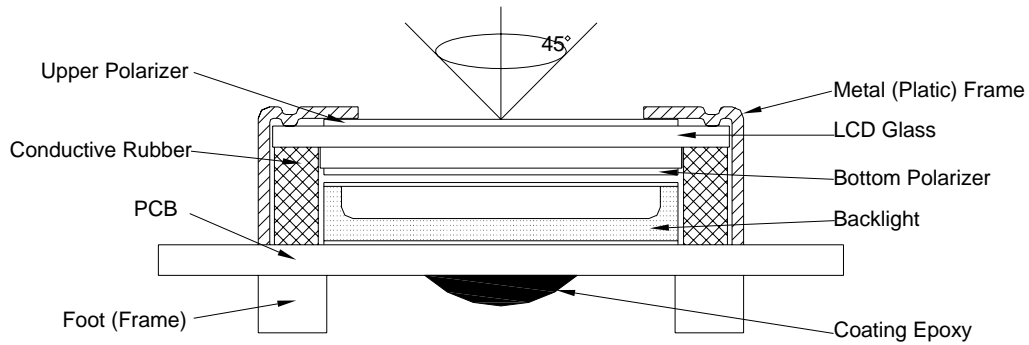

2. View Angle: with in 45° around perpendicular line.

7 - 2. Definition

1. COB

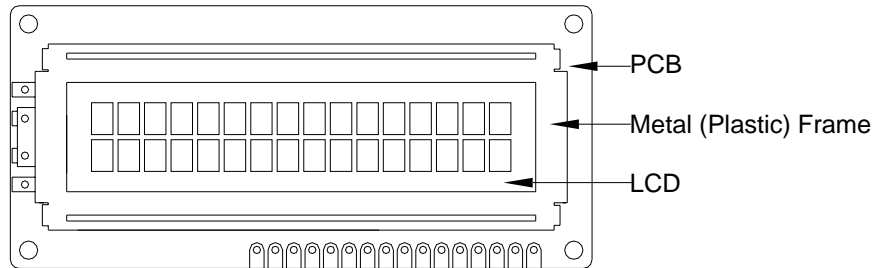

2. Heat Seal

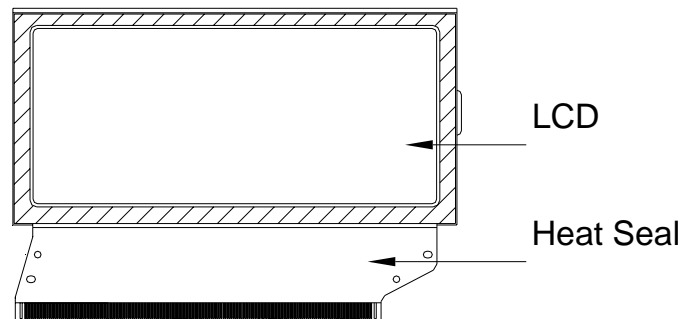

3. TAB and COG

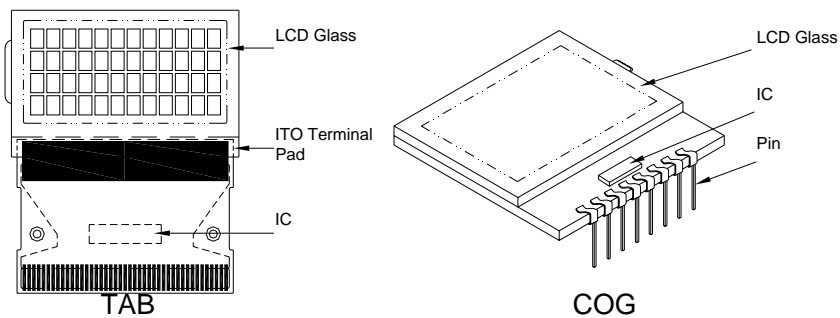

7-3. Sampling Plan and Acceptance

1. Sampling Plan

MIL - STD - 105E (||) ordinary single inspection is used.

2. Acceptance

Major defect: AQL = 0.65%

Minor defect: AQL = 1.5%

7-4. Criteria**1. COB**

Defect	Inspection Item	Inspection Standards	
Major	PCB copper flakes peeling off	Any copper flake in viewing Area should be greater than 1.0mm ²	Reject
Major	Height of coating epoxy	Exceed the dimension of drawing	Reject
Major	Void or hole of coating epoxy	Expose bonding wire or IC	Reject
Major	PCB cutting defect	Exceed the dimension of drawing	Reject

2. SMT

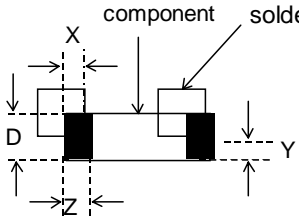
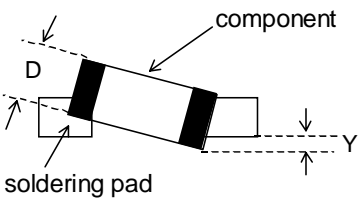
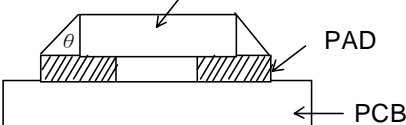
Defect	Inspection Item	Inspection Standards	
Minor	Component marking not readable		Reject
Minor	Component height	Exceed the dimension Of drawing	Reject
Major	Component solder defect (missing , extra, wrong component or wrong orientation)		Reject
Minor	Component position shift 	$X < 3/4Z$ $Y > 1/3D$	Reject Reject
Minor	Component tilt 	$Y > 1/3D$	Reject
Minor	Insufficient solder 	$\theta \leq 20^\circ$	Reject

3. Metal (Plastic) Frame

Defect	Inspection Item	Inspection Standards	
Major	Crack / breakage	Anywhere	
		W	L
		w<0.1mm	Any
Minor	Frame Scratch	0.1≤w<0.2mm	L≤5.0mm
		0.2≤w<0.3mm	L≤3.0mm
		w>0.3mm	Any
		Note : 1. Above criteria applicable to scratch lines with distance greater than 5mm. 2. Scratch on the back side of frame (not visible) can be ignored .	
			Acceptable of Dents / Pricks
Minor	Frame Dent , Prick $\Phi = \frac{L + W}{2}$	$\Phi \leq 1.0\text{mm}$	2
		$1.0 < \Phi \leq 1.5\text{mm}$	1
		$1.5\text{mm} < \Phi$	0
		Note : 1. Above criteria applicable to any two dents / pricks with distance greater than 5mm 2. Dent / prick on the back side of frame (not visible) can be ignored	
Minor	Frame Deformation	Exceed the dimension of drawing	
Minor	Metal Frame Oxidation	Any rust	

4. Flexible Film Connector (FFC)

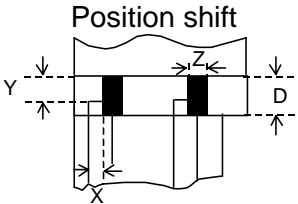
Defect	Inspection Item	Inspection Standards	
Minor	Tilted soldering	Within the angle +5°	Acceptable
Minor	Uneven solder joint /bump		Reject
Minor	Hole $\Phi = \frac{L + W}{2}$	Expose the conductive line	Reject
		$\Phi > 1.0\text{mm}$	Reject
Minor	Position shift 	$Y > 1/3D$	Reject
		$X > 1/2Z$	Reject

5. Screw

Defect	Inspection Item	Inspection Standards	
Major	Screw missing/loosen		Reject
Minor	Screw oxidation	Any rust	Reject
Minor	Screw deformation	Difficult to accept screw driver	Reject

6. Heatseal 、TCP 、FPC

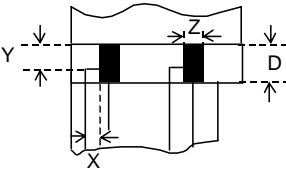
Defect	Inspection Item	Inspection Standards	
Major	Scratch expose conductive layer		Reject
Minor	HS Hole $\Phi = \frac{L+W}{2}$	$\Phi > 0.5\text{mm}$	Reject
Major	Adhesion strength	Less than the specification	Reject
Minor	Position shift 	$Y > 1/3D$	Reject
		$X > 1/2Z$	Reject
Major	Conductive line break		Reject

7. LED Backing Protective Film and Others

Defect	Inspection Item	Inspection Standards	
Minor	LED dirty, prick	Acceptable number of units	
		$\Phi \leq 0.10\text{mm}$	Ignore
		$0.10 < \Phi \leq 0.15\text{mm}$	2
		$0.15 < \Phi \leq 0.2\text{mm}$	1
		$\Phi > 0.2\text{mm}$	0
The distance between any two spots should be $\geq 5\text{mm}$ Any spot/dot/void outside of viewing area is acceptable			
Minor	Protective film tilt	Not fully cover LCD	Reject
Major	COG coating	Not fully cover ITO circuit	Reject

8. Electric Inspection

Defect	Inspection Item	Inspection Standards	
Major	Short		Reject
Major	Open		Reject

9. Inspection Specification of LCD

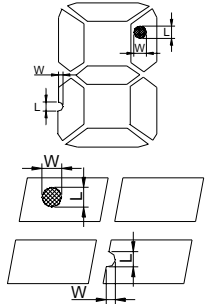
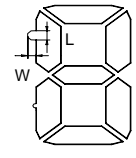
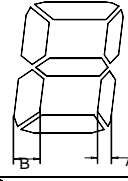
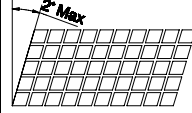
Defect	Inspect Item	Inspection Standards				
		W	$W \leq 0.03$	$0.03 < W \leq 0.05$	$W > 0.05$	
Minor	Linear Defect * Glass Scratch * Polarizer Scratch * Fiber and Linear material	L	$L < 5$	$L < 3$	Any	
		ACC. NO.	1	1	Reject	
		Note	L is the length and W is the width of the defect			
Minor	Black Spot and Polarizer Pricked * Foreign material between glass and polarizer or glass and glass * Polarizer hole or protuberance by external force	Φ	$\Phi \leq 0.1$	$0.1 < \Phi \leq 0.15$	$0.15 < \Phi \leq 0.2$	$\Phi > 0.2$
		ACC. NO.	3EA / 100mm ²	2	1	0
		Note	Φ is the average diameter of the defect. Distance between two defects > 10mm.			
Minor	White Spot and Bubble in polarizer * Unobvious transparent foreign material between glass and glass or glass and polarizer * Air protuberance between polarizer and glass	Φ	$\Phi \leq 0.3$	$0.3 < \Phi \leq 0.5$	$0.5 < \Phi$	
		ACC. NO.	3EA / 100mm ²	1	0	
		Note	Φ is the average diameter of the defect. Distance between two defects > 10mm.			
Minor	Segment Defect 	Φ	$\Phi \leq 0.10$	$0.10 < \Phi \leq 0.20$	$0.20 < \Phi \leq 0.25$	$\Phi > 0.25$
		ACC. NO.	3EA / 100mm ²	2	1	0
		Note	W is more than 1/2 segment width			Reject
			$\Phi = \frac{L + W}{2}$ Distance between two defect is 10mm			
Minor	Protuberant Segment  $\Phi = (L + W) / 2$	Φ	$\Phi \leq 0.10$	$0.10 < \Phi \leq 0.20$	$0.20 < \Phi \leq 0.25$	$\Phi > 0.25$
		W	Glue	$W \leq 1/2$ Seg $W < 0.2$	$W \leq 1/2$ Seg $W < 0.2$	Ignore
		ACC. NO.	3EA / 100mm ²	2	1	0
Minor	Assembly Mis-alignment  	1. Segment				
		B	$B \leq 0.4\text{mm}$	$0.4 < B \leq 1.0\text{mm}$	$B > 1.0\text{mm}$	
		B-A	$B-A < 1/2B$	$B-A < 0.2$	$B-A < 0.25$	
		Judge	Acceptable	Acceptable	Acceptable	
		2. Dot Matrix				
		Deformation > 2°			Reject	
Minor	Stain on LCD Panel Surface	Accept when stains can be wiped lightly with a soft cloth or a similar one. Otherwise, judged according to the above items: "Black spot" and "White Spot"				

8. RELIABILITY

NO.	Item	Condition	Criterion
1	High Temperature Operating	60°C , 96Hrs	No defect in cosmetic and operational function allowable.
2	Low Temperature Operating	-10°C , 96Hrs	
3	High Humidity	50°C , 90%RH, 96Hrs	
4	High Temperature Storage	70°C , 96Hrs	
5	Low Temperature Storage	-20°C , 96Hrs	
6	Vibration	Random wave 10 ~ 100Hz Acceleration: 2g 2 Hrs per direction(X,Y,Z)	Total current Consumption should be below double of initial value.
7	Thermal Shock	-10°C to 25°C to 60°C (60Min) (5Min) (60Min) 16Cycles	
8	ESD Testing	Contract Discharge Voltage: +1 ~ 5kV and -1 ~ -5kV Air Discharge Voltage: +1 ~ 8kV and -1 ~ -8kV	There will be discharged ten times at every discharging voltage cycle. The voltage gap is 1kV.

Note: 1) Above conditions are suitable for our company standard products.
2) For restrict products, the test conditions listed as above must be revised.

9. HANDLING PRECAUTION

(1) Mounting Method

The panel of the LCD Module consists of two thin glass plates with polarizers which easily get damaged since the Module is fixed by utilizing fitting holes in the printed circuit board. Extreme care should be taken when handling the LCD Modules.

(2) Caution of LCD handling & cleaning

When cleaning the display surface, use soft cloth with solvent (recommended below) and wipe lightly.

- Isopropyl alcohol
- Ethyl alcohol
- Trichloro trifluro thane

Do not wipe the display surface with dry or hard materials that will damage the polarizer surface.

Do not use the following solvent:

- Water
- Ketone
- Aromatics

(3) Caution against static charge

The LCD Module use C-MOS LSI drivers, so we recommend that you connect any unused input terminal to VDD or VSS, do not input any signals before power is turned on. And ground your body, Work/assembly table. And assembly equipment to protect against static electricity.

(4) Packaging

- Modules use LCD elements, and must be treated as such. Avoid intense shock and falls from a height.
- To prevent modules from degradation. Do not operate or store them exposed directly to sunshine or high temperature/humidity.

(5) Caution for operation

- It is indispensable to drive LCD's within the specified voltage limit since the higher voltage than the limit shorten LCD life. An electrochemical reaction due to direct current causes LCD deterioration, Avoid the use of direct current drive.
- Response time will be extremely delayed at lower temperature than the operating temperature range and on the other hand at higher temperature LCD's show dark color in them. However those phenomena do not mean malfunction or out of order with LCD's. Which will come back in the specified operating temperature range.
- If the display area is pushed hard during operation, some font will be abnormally displayed but it resumes normal condition after turning off once.
- A slight dew depositing on terminals is a cause for electro-chemical reaction resulting in terminal open circuit.

Usage under the relative condition of 40°C, 50%RH or less is reequired.

(6) Storage

In the case of storing for a long period of time (for instance.) For years) for the purpose or replacement use, The following ways are recommended.

- Storage in a polyethylene bag with sealed so as not to enter fresh air outside in it, And with no desiccant.
- Placing in a dark place where neither exposure to direct sunlight nor light is. Keeping temperature in the specified storage temperature range.
- Storing with no touch on polarizer surface by the anything else. (It is recommended to store them as they have been contained in the inner container at the time of delivery)

(7) Safety

- It is recommendable to crash damaged or unnecessary LCD into pieces and wash off liquid crystal by using solvents such as acetone and ethanol.

Which should be burned up later.

- When any liquid crystal leaked out of a damaged glass cell comes in contact with your hands, please wash it off well with soap and water.

10. OUTLINE DIMENSION

