



PRODUCT SPECIFICATION

MONO LCD MODULE MODEL: G1206K4SGW6G-B0 Ver:1.0

< ◇ > Preliminary Specification

< ◆ > Finally Specification

CUSTOMER'S APPROVAL	
CUSTOMER :	
SIGNATURE:	DATE:

APPROVED BY	PM REVIEWED	PD REVIEWED	PREPARED BY

Table of Contents

No.	Contents	Page
1.	FEATURES.....	4
2.	MECHANICAL SPECIFICATIONS	4
3.	ELECTRICAL SPECIFICATIONS	4
4.	TERMINAL FUNCTIONS AND BLOCK DIAGRAM	6
5.	TIMING CHARACTERISTICS	8
6.	COMMAND LIST	10
7.	QUALITY SPECIFICATIONS	11
8.	RELIABILITY	16
9.	HANDLING PRECAUTION	17
10.	OUTLINE DIMENSION	18

1. Features

The features of LCD are as follows

- * Display mode : STN/ Blue/Transmissive/Negative
- * Drive IC : ST7565R
- * Interface Input Data : 6800,8080 Series or SPI-4
- * Driving Method : 1/65 Duty, 1/9 Bias
- * Viewing Direction : 6 O'clock
- * Backlight : LED/White

2. MECHANICAL SPECIFICATIONS

Item	Specification	Unit
Module Size	73(W) x53(H) x 6.2(D)	mm
Number of Dots	128 X 64 Dots	-
Viewing Area	61(W) x 43(H)	mm
Activity Area	56.27(W)x38.35(H)	mm
Dot Size	0.39 (W) x 0.55(H)	mm
Dot Pitch	0.44(W) x0.60(H)	mm

3. ELECTRICAL SPECIFICATIONS

3-1 ABSOLUTR MAZIMUM RATINGS (Ta = 25 °C)

Item	Symbol	Standard Value			Unit
		Min.	Typ.	Max.	
Supply Voltage For Logic	$V_{DD} - V_{SS}$	-0.3	-	3.6	V
Supply Voltage For LCD Drive	$V_O - V_{SS}$	-0.3	-	13.5	V
Input Voltage	V_{in}	-0.3	-	$V_{DD}+0.3$	V
Operating Temp.	T_{op}	-20	-	+70	°C
Storage Temp.	T_{st}	-30	-	+80	°C

3-2 ELECTRICAL CHARACTERISTICS

Item		Symbol	Test Condition	Min.	Typ.	Max.	Unit
Logic supply Voltage		$V_{DD} - V_{SS}$	$T_a = 25\text{ }^\circ\text{C}$ $V_{DD}=3.3V \pm 10\%$	3.0	3.3	3.6	V
LCD Drive		$V_O - V_{SS}$		9.7	10	10.3	V
Input Voltage	"H" Level	V_{IH}		0.8VDD	-	VDD	V
	"L" Level	V_{IL}		VSS	-	0.2VDD	V
Frame Frequency		f_{FLM}		-	64	-	Hz
Current Consumption		I_{DD}		-	13.0	-	mA

*. NOTE: The response time will be extremely slow when the operating temperature is around $-20\text{ }^\circ\text{C}$, and the back ground will become darker at high temperature operating.

3-3 BACKLIGHT**3-3-1. Absolute Maximum Ratings**

Item	Symbol	Condition	Min.	Typ.	Max.	Unit
Forward Current	IF	$T_a = 25\text{ }^\circ\text{C}$	-	-	15	mA
Reverse Voltage	VR		-	-	5	V
Power Dissipation	PD		-	-	48	mW

3-3-2. Electrical-optical Characteristics

Item	Symbol	Condition	Min.		Typ.		Max.		Unit
Forward Voltage	VF	$I_f=15\text{mA}$ $T_a = 25\text{ }^\circ\text{C}$	2.9		3.1		3.2		V
Average Luminous Intensity	I_v		35		50		-		cd/m^2
Colour coordinate	-		X	Y	X	Y	X	Y	-
			0.25	0.25	0.28	0.28	0.31	0.31	

The brightness is measured without LCD panel
 For operation above $25\text{ }^\circ\text{C}$, The I_{fm} & P_d must be derated, the current derating is $-0.36\text{mA}/\text{ }^\circ\text{C}$ for DC drive and $-0.86\text{mA}/\text{ }^\circ\text{C}$ for Pulse drive, the Power dissipation is $-0.75\text{mW}/\text{ }^\circ\text{C}$. The product working current must not more than the 60% of the I_{fm} or I_{fp} according to the working temperature.

4. TERMINAL FUNCTIONS AND BLOCK DIAGRAM

4-1. INTERFACE PIN FUNCTION DESCRIPTION

PIN NO.	SYMBOL	FUNCIONS
1	CS1B	Chip select signal
2	RST	Reset signal
3	A0	Register select input pin
4	/WR(R/W)	<ul style="list-style-type: none"> When connected to 8080 series MPU, this pin is treated as the "/WR" signal of the 8080 MPU and is LOW-active. The signals on the data bus are latched at the rising edge of the /WR signal. When connected to 6800 series MPU, this pin is treated as the "R/W" signal of the 6800 MPU and decides the access type : When R/W = "H": Read. When R/W = "L": Write.
5	/RD(E)	<ul style="list-style-type: none"> When connected to 8080 series MPU, this pin is treated as the "/RD" signal of the 8080 MPU and is LOW-active. The data bus is in an output status when this signal is "L". When connected to 6800 series MPU, this pin is treated as the "E" signal of the 6800 MPU and is HIGH-active. This is the enable clock input terminal of the 6800 Series MPU.
6-13	DB0-DB7	Data bus
14	VDD	Supply voltage for logical circuit(3.3V)
15	VSS	Ground (0V)
16	VOOUT	DC/DC voltage converter.
17	CAP3P	DC/DC voltage converter. Connect a capacitor between this terminal
18	CAP1N	
19	CAP1P	
20	CAP2P	
21	CAP2N	
22-26	V4-V0	LCD Bias voltage
27	C86	<p>This is the MPU interface selection pin.</p> <p>C86 = "H": 6800 Series MPU interface.</p> <p>C86 = "L": 8080 Series MPU interface.</p>
28	PSB	This pin configures the interface to be parallel mode or serial mode.

4-2 BLOCK DIAGRAM

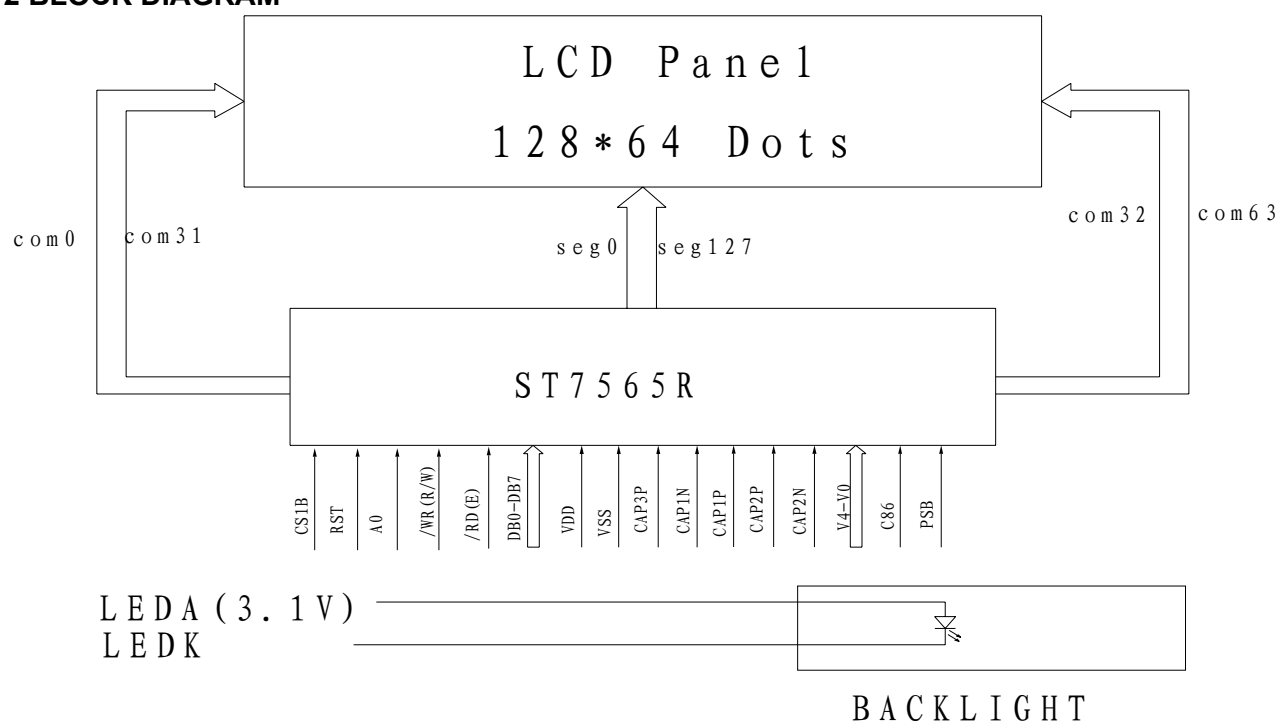

4-3 POWER SUPPLY
when the voltage regulator
internal resistor is used

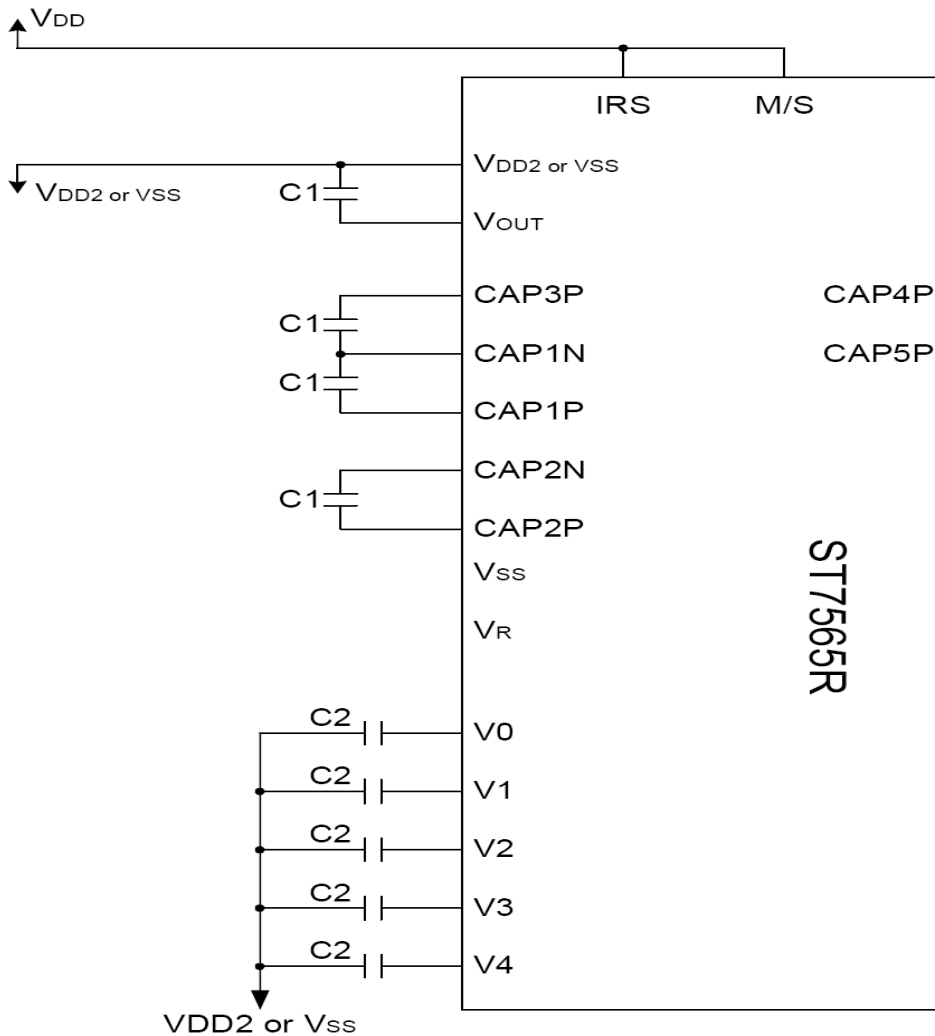

Item	Set value	unit
C1	1 ~ 2.2	uF
C2	0.1 ~ 1	uF

Note:

- C1 ~ C2 are determined by the size of the LCD being driven.
- The recommended panel size is smaller than 1.8".
- If the panel loading is too heavy and cause poor display quality, adding V0 capacitor can improve display quality.

5. TIMING CHARACTERISTICS

5.1 8080 serial read/write mode timing characteristics

(V_{DD} = 3.3V, T_a = -30 to 85°C)

Item	Signal	Symbol	Condition	Rating		Units
				Min.	Max.	
Address hold time	A0	t _{AH8}		0	—	Ns
Address setup time		t _{AW8}		0	—	
System cycle time		t _{CYC8}		240	—	
Enable L pulse width (WRITE)	WR	t _{CCLW}		80	—	
Enable H pulse width (WRITE)		t _{CCHW}		80	—	
Enable L pulse width (READ)	RD	t _{CCLR}		140	—	
Enable H pulse width (READ)		t _{CCHR}		80	—	
WRITE Data setup time	D0 to D7	t _{DS8}		40	—	
WRITE Address hold time		t _{DH8}		0	—	
READ access time		t _{ACC8}	CL = 100 pF	—	70	
READ Output disable time		t _{OH8}	CL = 100 pF	5	50	

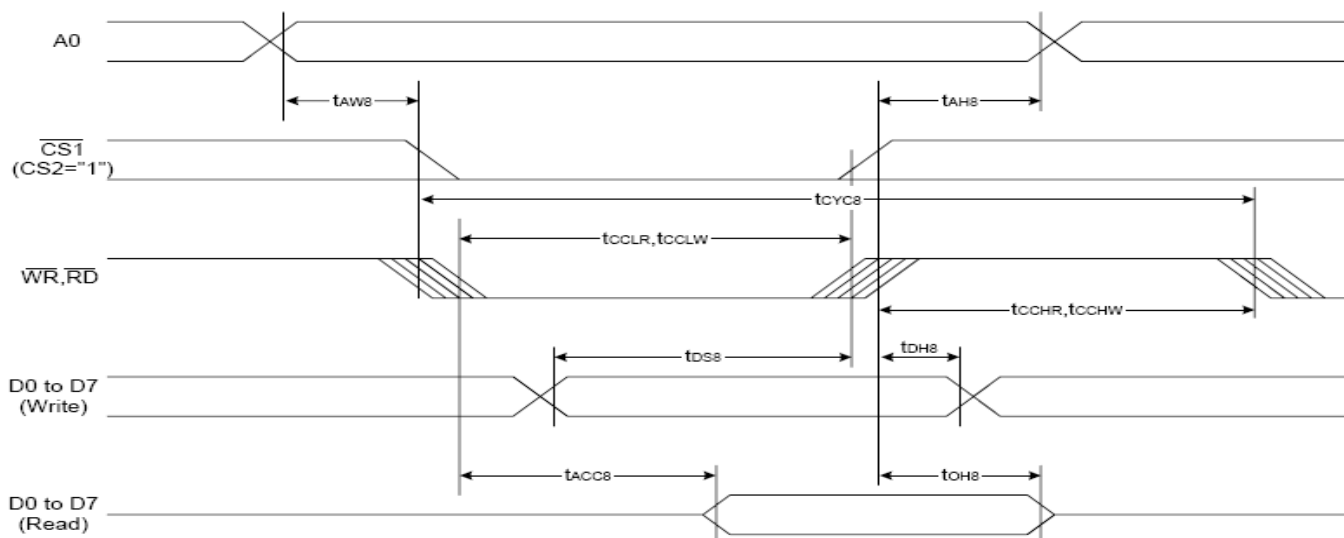

5.2 6800 series read/write mode timing characteristics

Item	Signal	Symbol	Condition	Rating		Units
				Min.	Max.	
Address hold time	A0	t _{AH6}		0	—	ns
Address setup time		t _{AW6}		0	—	
System cycle time		t _{CYC6}		240	—	
Enable L pulse width (WRITE)	WR	t _{EWLW}		80	—	
Enable H pulse width (WRITE)		t _{EWHW}		80	—	
Enable L pulse width (READ)	RD	t _{EWLR}		80	—	
Enable H pulse width (READ)		t _{EWHR}		140	—	
WRITE Data setup time	D0 to D7	t _{DS6}		40	—	
WRITE Address hold time		t _{DH6}		0	—	
READ access time		t _{ACC6}	CL = 100 pF	—	70	
READ Output disable time		t _{OH6}	CL = 100 pF	5	50	

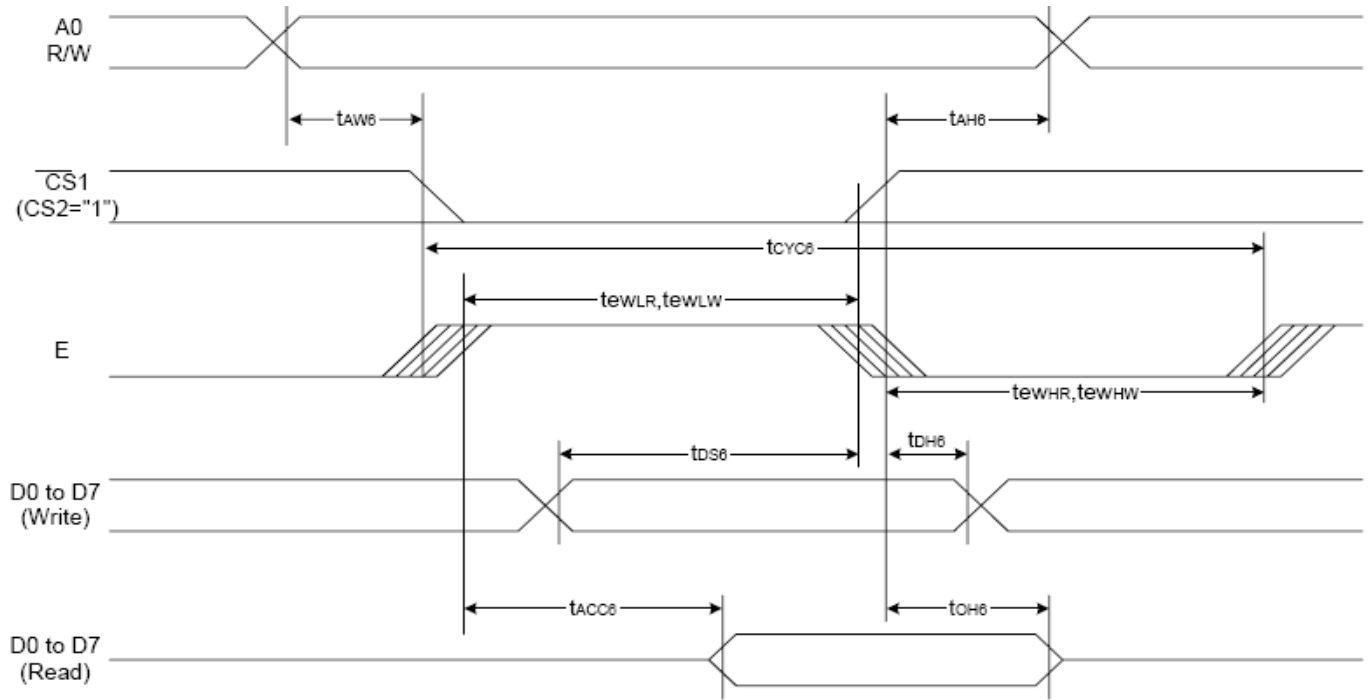

5.3 The 4-line SPI Interface

Item	Signal	Symbol	Condition	Rating		Units
				Min.	Max.	
4-line SPI Clock Period	SCL	T_{scyc}		50	—	ns
SCL "H" pulse width		T_{shw}		25	—	
SCL "L" pulse width		T_{SLW}		25	—	
Address setup time	A0	T_{sAS}		20	—	
Address hold time		T_{sah}		10	—	
Data setup time	SI	T_{sds}		20	—	
Data hold time		T_{SDH}		10	—	
CS-SCL time	CS	T_{css}		20	—	
CS-SCL time		T_{csh}		40	—	

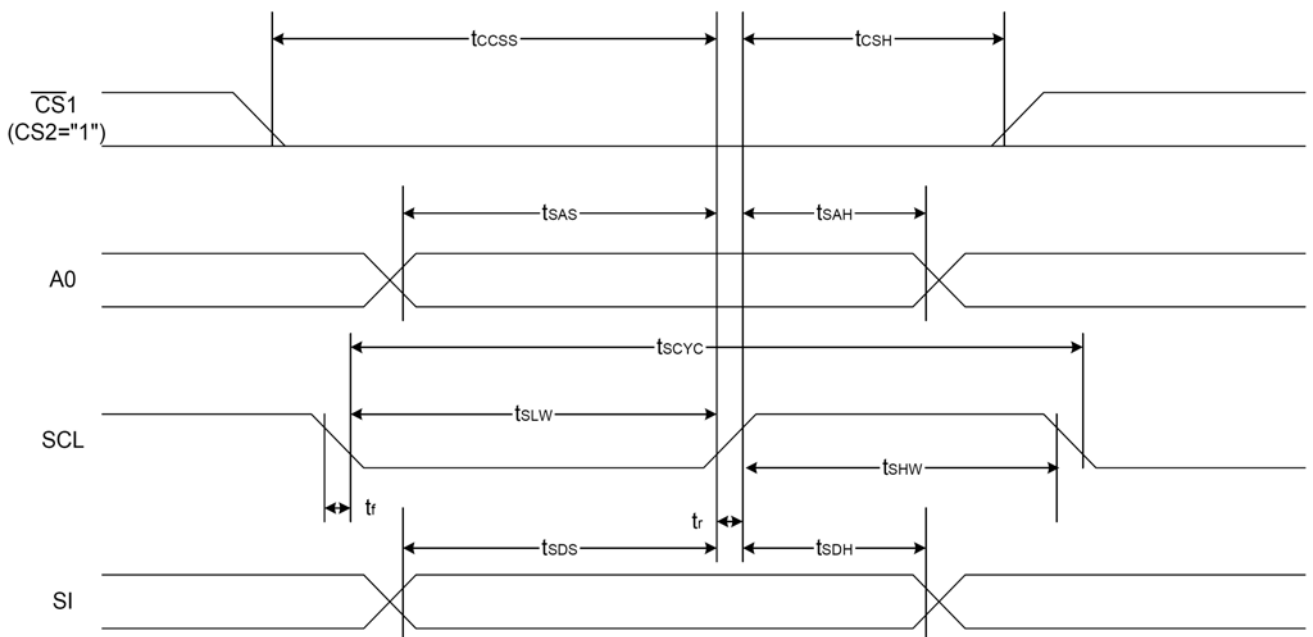

6. COMMAND LIST

Command	Command Code									Function				
	A0	/RD	/WR	D7	D6	D5	D4	D3	D2		D1	D0		
(1) Display ON/OFF	0	1	0	1	0	1	0	1	1	1	0	1	LCD display ON/OFF 0: OFF, 1: ON	
(2) Display start line set	0	1	0	0	1	Display start address					1	Sets the display RAM display start line address		
(3) Page address set	0	1	0	1	0	1	1	Page address				1	Sets the display RAM page address	
(4) Column address set upper bit	0	1	0	0	0	0	1	Most significant column address				1	Sets the most significant 4 bits of the display RAM column address. Sets the least significant 4 bits of the display RAM column address.	
Column address set lower bit				0	0	0	0	Least significant column address						
(5) Status read	0	0	1	Status				0	0	0	0	1	Reads the status data	
(6) Display data write	1	1	0	Write data							0	Writes to the display RAM		
(7) Display data read	1	0	1	Read data							0	Reads from the display RAM		
(8) ADC select	0	1	0	1	0	1	0	0	0	0	0	0	1	Sets the display RAM address SEG output correspondence 0: normal, 1: reverse
(9) Display normal/reverse	0	1	0	1	0	1	0	0	1	1	0	1	1	Sets the LCD display normal/ reverse 0: normal, 1: reverse
(10) Display all points ON/OFF	0	1	0	1	0	1	0	0	1	0	0	1	1	Display all points 0: normal display 1: all points ON
(11) LCD bias set	0	1	0	1	0	1	0	0	0	1	0	1	1	Sets the LCD drive voltage bias ratio 0: 1/9 bias, 1: 1/7 bias (ST7565R)
(12) Read-modify-write	0	1	0	1	1	1	0	0	0	0	0	0	0	Column address increment At write: +1 At read: 0
(13) End	0	1	0	1	1	1	0	1	1	1	0	0	0	Clear read/modify/write
(14) Reset	0	1	0	1	1	1	0	0	0	1	0	0	0	Internal reset
(15) Common output mode select	0	1	0	1	1	0	0	0	*	*	*	1	*	Select COM output scan direction 0: normal direction 1: reverse direction
(16) Power control set	0	1	0	0	0	1	0	1	Operating mode			0	1	Select internal power supply operating mode
(17) V ₀ voltage regulator internal resistor ratio set	0	1	0	0	0	1	0	0	Resistor ratio			0	1	Select internal resistor ratio(Rb/Ra) mode
(18) Electronic volume mode set	0	1	0	1	0	0	0	0	0	0	0	1	1	Set the V ₀ output voltage electronic volume register
Electronic volume register set				0	0	Electronic volume value								
(19) Sleep mode set	0	1	0	1	0	1	0	1	1	0	0	1	1	0: Sleep mode, 1: Normal mode
(20) Booster ratio set	0	1	0	1	1	1	1	1	0	0	0	0	0	select booster ratio 00: 2x,3x,4x 01: 5x 11: 6x
(21) NOP	0	1	0	1	1	1	0	0	0	0	1	1	1	Command for non-operation
(22) Test	0	1	0	1	1	1	1	*	*	*	*	*	*	Command for IC test. Do not use this command

7. QUALITY SPECIFICATIONS

7 - 1. LCM Appearance and Electric inspection Condition

1. Inspection will be done by placing LCM 30cm away from inspector's eyeballs under normal illumination.

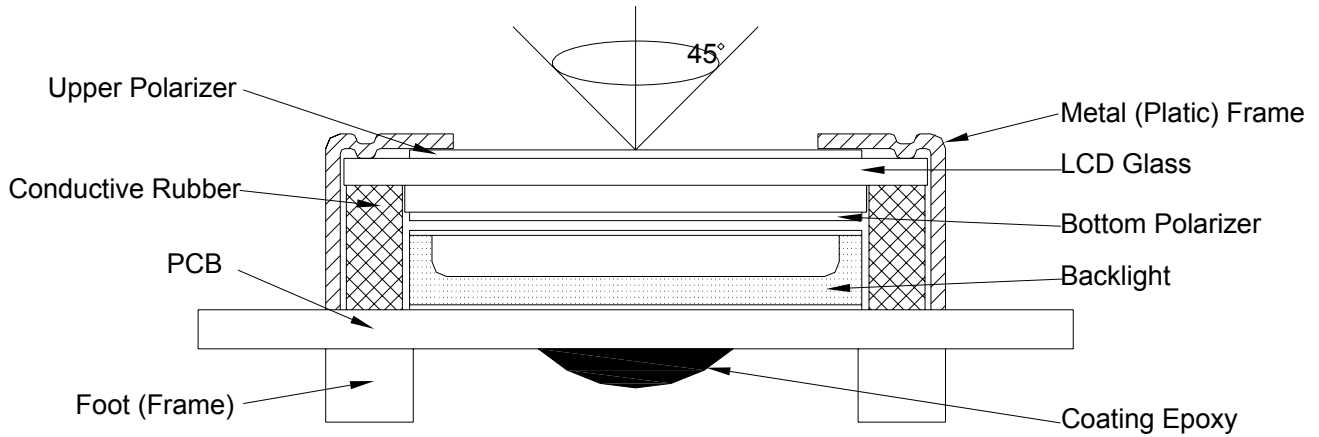

2. View Angle: with in 45° around perpendicular line.

7 - 2. Definition

1. COB

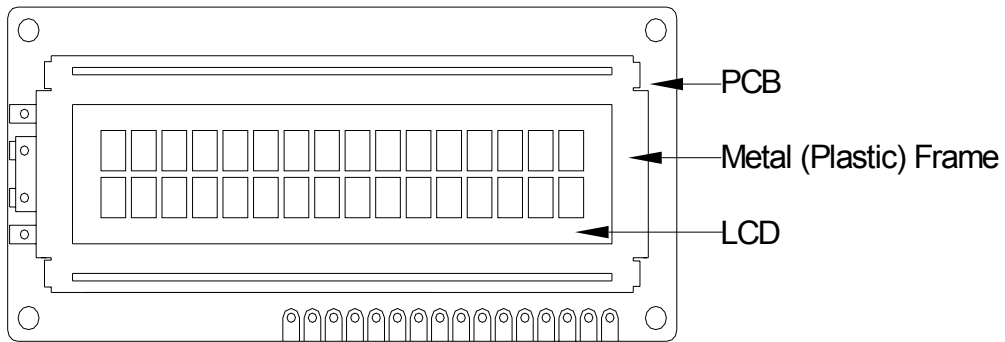

2. Heat Seal

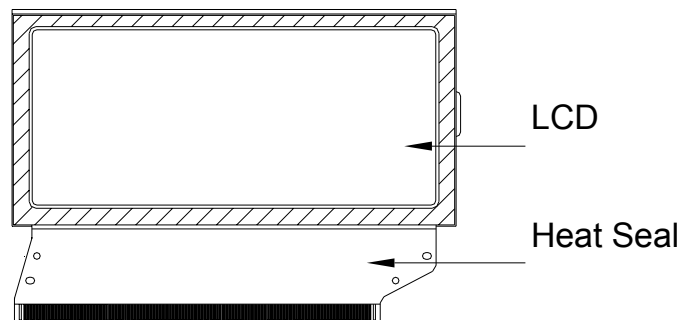

3. TAB and COG

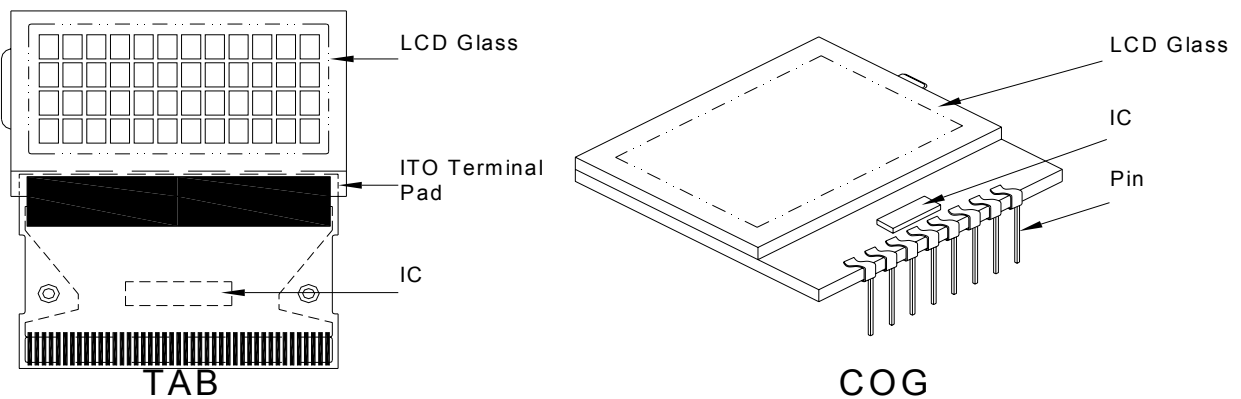

7-3. Sampling Plan and Acceptance

1. Sampling Plan

MIL - STD - 105E (||) ordinary single inspection is used.

2. Acceptance

Major defect: AQL = 0.65%

Minor defect: AQL = 1.5%

7-4. Criteria

1. COB

Defect	Inspection Item	Inspection Standards	
Major	PCB copper flakes peeling off	Any copper flake in viewing Area should be greater than 1.0mm ²	Reject
Major	Height of coating epoxy	Exceed the dimension of drawing	Reject
Major	Void or hole of coating epoxy	Expose bonding wire or IC	Reject
Major	PCB cutting defect	Exceed the dimension of drawing	Reject

2. SMT

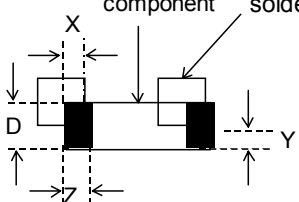
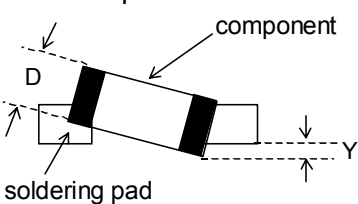
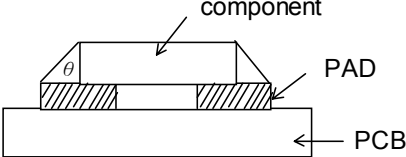
Defect	Inspection Item	Inspection Standards	
Minor	Component marking not readable		Reject
Minor	Component height	Exceed the dimension Of drawing	Reject
Major	Component solder defect (missing , extra, wrong component or wrong orientation)		Reject
Minor	<p>Component position shift</p> 	$X < 3/4Z$ $Y > 1/3D$	Reject Reject
Minor	<p>Component tilt</p> 	$Y > 1/3D$	Reject
Minor	<p>Insufficient solder</p> 	$\theta \leq 20^\circ$	Reject

3. Metal (Plastic) Frame

Defect	Inspection Item	Inspection Standards		
Major	Crack / breakage	Anywhere		
			Reject	
Minor	Frame Scratch	W	L	Acceptable of Scratch
		$w < 0.1\text{mm}$	Any	Ignore
		$0.1 \leq w < 0.2\text{mm}$	$L \leq 5.0\text{mm}$	2
		$0.2 \leq w < 0.3\text{mm}$	$L \leq 3.0\text{mm}$	1
		$w > 0.3\text{mm}$	Any	0
Note : 1. Above criteria applicable to scratch lines with distance greater than 5mm. 2. Scratch on the back side of frame (not visible) can be ignored .				
Minor	Frame Dent , Prick $\Phi = \frac{L + W}{2}$			Acceptable of Dents / Pricks
		$\Phi \leq 1.0\text{mm}$		2
		$1.0 < \Phi \leq 1.5\text{mm}$		1
		$1.5\text{mm} < \Phi$		0
Note : 1. Above criteria applicable to any two dents / pricks with distance greater than 5mm 2. Dent / prick on the back side of frame (not visible) can be ignored				
Minor	Frame Deformation	Exceed the dimension of drawing		
Minor	Metal Frame Oxidation	Any rust		

4. Flexible Film Connector (FFC)

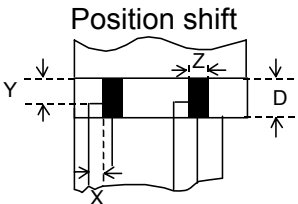
Defect	Inspection Item	Inspection Standards	
Minor	Tilted soldering	Within the angle $+5^\circ$	Acceptable
Minor	Uneven solder joint /bump		Reject
Minor	Hole $\Phi = \frac{L + W}{2}$	Expose the conductive line	Reject
		$\Phi > 1.0\text{mm}$	Reject
Minor		$Y > 1/3D$	Reject
		$X > 1/2Z$	Reject

5. Screw

Defect	Inspection Item	Inspection Standards	
Major	Screw missing/loosen		Reject
Minor	Screw oxidation	Any rust	Reject
Minor	Screw deformation	Difficult to accept screw driver	Reject

6. Heatseal 、TCP 、FPC

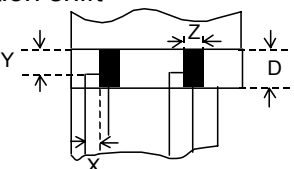
Defect	Inspection Item	Inspection Standards	
Major	Scratch expose conductive layer		Reject
Minor	HS Hole $\Phi = \frac{L+W}{2}$	$\Phi > 0.5\text{mm}$	Reject
Major	Adhesion strength	Less than the specification	Reject
Minor	Position shift 	$Y > 1/3D$	Reject
		$X > 1/2Z$	Reject
Major	Conductive line break		Reject

7. LED Backing Protective Film and Others

Defect	Inspection Item	Inspection Standards	
Minor	LED dirty, prick	Acceptable number of units	
		$\Phi \leq 0.10\text{mm}$	Ignore
		$0.10 < \Phi \leq 0.15\text{mm}$	2
		$0.15 < \Phi \leq 0.2\text{mm}$	1
		$\Phi > 0.2\text{mm}$	0
		The distance between any two spots should be $\geq 5\text{mm}$ Any spot/dot/void outside of viewing area is acceptable	
Minor	Protective film tilt	Not fully cover LCD	Reject
Major	COG coating	Not fully cover ITO circuit	Reject

8. Electric Inspection

Defect	Inspection Item	Inspection Standards	
Major	Short		Reject
Major	Open		Reject

9. Inspection Specification of LCD

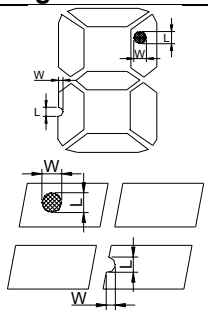
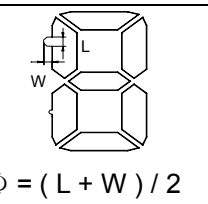
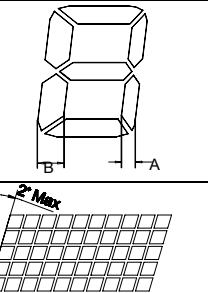
Defect	Inspect Item	Inspection Standards				
		W	$W \leq 0.03$	$0.03 < W \leq 0.05$	$W > 0.05$	
Minor	Linear Defect * Glass Scratch * Polarizer Scratch * Fiber and Linear material	L	$L < 5$	$L < 3$	Any	
		ACC. NO.	1	1	Reject	
		Note	L is the length and W is the width of the defect			
Minor	Black Spot and Polarizer Pricked * Foreign material between glass and polarizer or glass and glass * Polarizer hole or protuberance by external force	Φ	$\Phi \leq 0.1$	$0.1 < \Phi \leq 0.15$	$0.15 < \Phi \leq 0.2$	$\Phi > 0.2$
		ACC. NO.	3EA / 100mm ²	2	1	0
		Note	Φ is the average diameter of the defect. Distance between two defects > 10mm.			
Minor	White Spot and Bubble in polarizer * Unobvious transparent foreign material between glass and glass or glass and polarizer * Air protuberance between polarizer and glass	Φ	$\Phi \leq 0.3$	$0.3 < \Phi \leq 0.5$	$0.5 < \Phi$	
		ACC. NO.	3EA / 100mm ²	1	0	
		Note	Φ is the average diameter of the defect. Distance between two defects > 10mm.			
Minor	Segment Defect 	Φ	$\Phi \leq 0.10$	$0.10 < \Phi \leq 0.20$	$0.20 < \Phi \leq 0.25$	$\Phi > 0.25$
		ACC. NO.	3EA / 100mm ²	2	1	0
		Note	W is more than 1/2 segment width			Reject
			$\Phi = \frac{L + W}{2}$ Distance between two defect is 10mm			
Minor	Protuberant Segment  $\Phi = (L + W) / 2$	Φ	$\Phi \leq 0.10$	$0.10 < \Phi \leq 0.20$	$0.20 < \Phi \leq 0.25$	$\Phi > 0.25$
		W	Glue	$W \leq 1/2$ Seg $W < 0.2$	$W \leq 1/2$ Seg $W < 0.2$	Ignore
		ACC. NO.	3EA / 100mm ²	2	1	0
Minor	Assembly Mis-alignment 	1. Segment				
		B	$B \leq 0.4\text{mm}$	$0.4 < B \leq 1.0\text{mm}$	$B > 1.0\text{mm}$	
		B-A	$B-A < 1/2B$	$B-A < 0.2$	$B-A < 0.25$	
		Judge	Acceptable	Acceptable	Acceptable	
		2. Dot Matrix				
	Deformation > 2°			Reject		
Minor	Stain on LCD Panel Surface	Accept when stains can be wiped lightly with a soft cloth or a similar one. Otherwise, judged according to the above items: "Black spot" and "White Spot"				

8. RELIABILITY

NO.	Item	Condition	Criterion
1	High Temperature Operating	70°C, 96Hrs	No defect in cosmetic and operational function allowable. Total current Consumption should be below double of initial value.
2	Low Temperature Operating	-20°C, 96Hrs	
3	High Humidity	50°C, 90%RH, 96Hrs	
4	High Temperature Storage	80°C, 96Hrs	
5	Low Temperature Storage	-30°C, 96Hrs	
6	Vibration	Random wave 10 ~ 100Hz Acceleration: 2g 2 Hrs per direction(X,Y,Z)	
7	Thermal Shock	-20°C to 25°C to 70°C (60Min) (5Min) (60Min) 16Cycles	
8	ESD Testing	Contract Discharge Voltage: +1 ~ 5kV and -1 ~ -5kV Air Discharge Voltage: +1 ~ 8kV and -1 ~ -8kV	

Note: 1) Above conditions are suitable for our company standard products.

2) For restrict products, the test conditions listed as above must be revised.

9. HANDLING PRECAUTION

(1) Mounting Method

The panel of the LCD Module consists of two thin glass plates with polarizers which easily get damaged since the Module is fixed by utilizing fitting holes in the printed circuit board.

Extreme care should be taken when handling the LCD Modules.

(2) Caution of LCD handling & cleaning

When cleaning the display surface, use soft cloth with solvent (recommended below) and wipe lightly.

- Isopropyl alcohol
- Ethyl alcohol
- Trichloro trifluro thane

Do not wipe the display surface with dry or hard materials that will damage the polarizer surface.

Do not use the following solvent:

- Water
- Ketone
- Aromatics

(3) Caution against static charge

The LCD Module use C-MOS LSI drivers, so we recommend that you connect any unused input terminal to VDD or VSS, do not input any signals before power is turned on. And ground your body, Work/assembly table. And assembly equipment to protect against static electricity.

(4) Packaging

- Modules use LCD elements, and must be treated as such. Avoid intense shock and falls from a height.
- To prevent modules from degradation. Do not operate or store them exposed directly to sunshine or high temperature/humidity.

(5) Caution for operation

- It is indispensable to drive LCD's within the specified voltage limit since the higher voltage than the limit shorten LCD life. An electrochemical reaction due to direct current causes LCD deterioration, Avoid the use of direct current drive.
- Response time will be extremely delayed at lower temperature than the operating temperature range and on the other hand at higher temperature LCD's show dark color in them. However those phenomena do not mean malfunction or out of order with LCD's. Which will come back in the specified operating temperature range.
- If the display area is pushed hard during operation, some font will be abnormally displayed but it resumes normal condition after turning off once.
- A slight dew depositing on terminals is a cause for electro-chemical reaction resulting in terminal open circuit.

Usage under the relative condition of 40°C, 50%RH or less is reequired.

(6) Storage

In the case of storing for a long period of time (for instance.) For years) for the purpose or replacement use, The following ways are recommended.

- Storage in a polyethylene bag with sealed so as not to enter fresh air outside in it, And with no desiccant.
- Placing in a dark place where neither exposure to direct sunlight nor light is. Keeping temperature in the specified storage temperature range.
- Storing with no touch on polarizer surface by the anything else. (It is recommended to store them as they have been contained in the inner container at the time of delivery)

(7) Safety

- It is recommendable to crash damaged or unnecessary LCD into pieces and wash off liquid crystal by using solvents such as acetone and ethanol. Which should be burned up later.
- When any liquid crystal leaked out of a damaged glass cell comes in contact with your hands, please wash it off well with soap and water.

10. OUTLINE DIMENSION

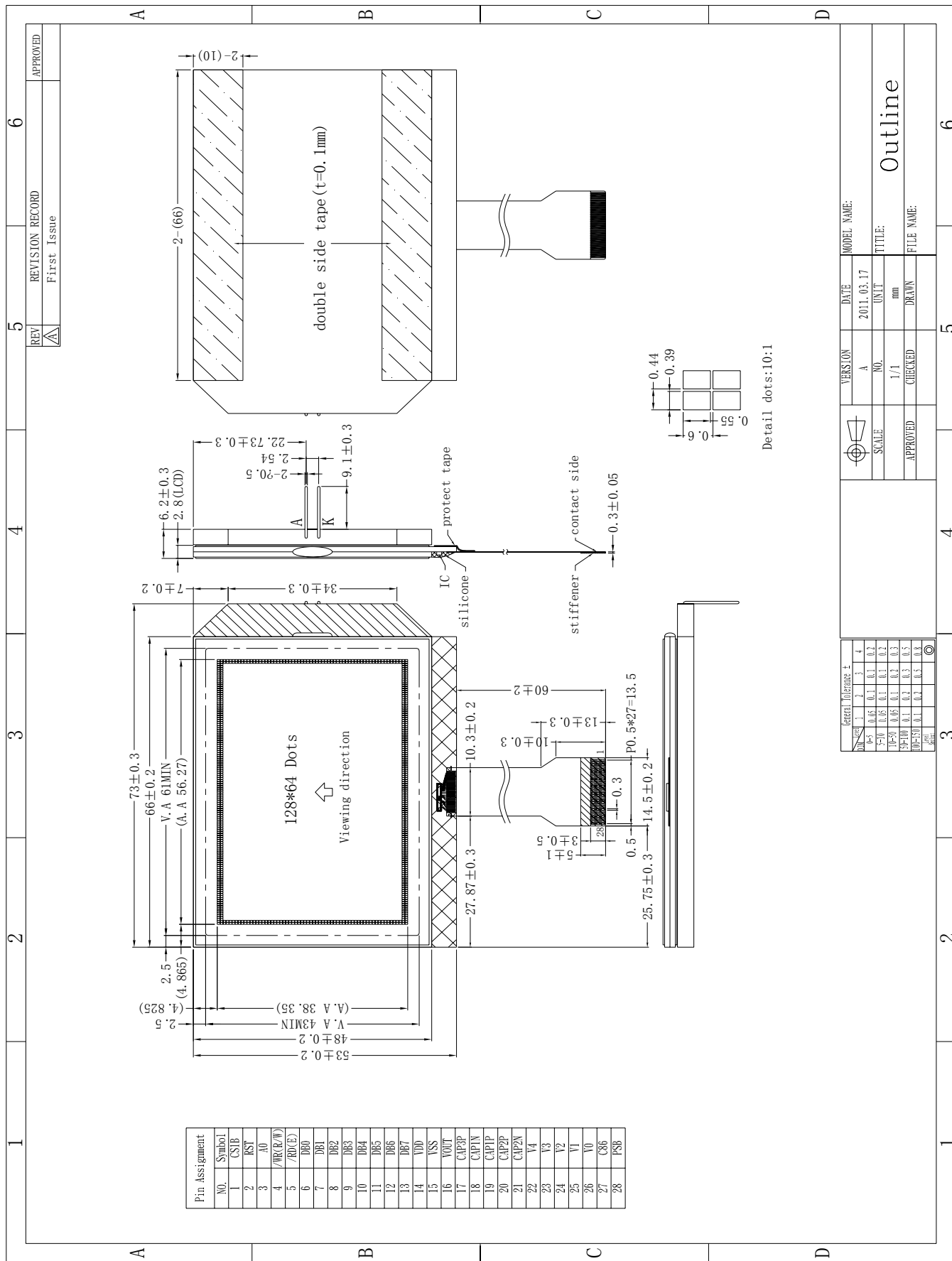

REVISION RECORD	APPROVED	
REV: A	First Issue	
VERSION	DATE	MODEL NAME:
A	2011.03.17	
NO.	UNIT	TITLE:
1/1	mm	Outline
CHECKED	DRAWN	FILE NAME:

6

5

4

3

2

1