

**ROHS****PRODUCT SPECIFICATION****MONO LCD MODULE**  
**MODEL: G1206J9FSW6G-A0 Ver: 1.0**

&lt; ◇ &gt; Preliminary Specification

&lt; ◆ &gt; Finally Specification

CUSTOMER'S APPROVAL	
CUSTOMER :	
SIGNATURE:	DATE:

APPROVED BY	PM REVIEWED	PD REVIEWED	PREPARED BY

## Revision Status

Version	Revise Date	Page	Content	Modified By
Ver. 1.0	2011.05.07		First Issued	

## Table of Contents

No.	Contents	Page
1.	FEATURES .....	4
2.	MECHANICAL SPECIFICATIONS .....	4
3.	ELECTRICAL SPECIFICATIONS .....	5
4.	TERMINAL FUNCTIONS AND BLOCK DIAGRAM .....	6
5.	TIMING CHARACTERISTICS.....	8
6.	INSTRUCTION SET.....	9
7.	QUALITY SPECIFICATIONS.....	10
8.	RELIABILITY .....	15
9.	HANDLING PRECAUTION .....	16
10.	OUTLINE DIMENSION .....	17

## 1. FEATURES

The features of LCD are as follows

- \* Display mode : FSTN /Transflective/positive
- \* Drive IC : ST7565R
- \* Interface Input Data : SPI-4
- \* Driving Method : 1/65Duty, 1/9 Bias
- \* Viewing Direction : 6 O'clock
- \* Backlight : LED/White
- \* Sample NO. : G1206J9FSW6G-A0\_01/20110506

## 2. MECHANICAL SPECIFICATIONS

Item	Specification	Unit
Module Size	58.2(W) x 41.7(H) x 5.7(D)	mm
Number of Dots	128x64 Dots	
View display area	50(W) x 25(H)	mm
Activity Display Area	46.05(W) x 23.01 (H)	mm
Dot Size	0.33(W) x 0.33(H)	mm
Dot Pitch	0.36(W) x 0.36(H)	

## 3. ELECTRICAL SPECIFICATIONS

### 3-1. ABSOLUTR MAZIMUM RATINGS (Ta=25 °C)

Item	Symbol	Standard Value			Unit
		Min.	Typ.	Max.	
Supply Voltage For Logic	V <sub>DD</sub>	-0.3		3.6	V
Supply Voltage For LCD Drive	V <sub>LCD</sub>	-0.3	-	13.5	V
Operating Temp.	Top	-20	-	+70	°C
Storage Temp.	Tst	-30	-	+80	°C

\*. NOTE: The response time will be extremely slow when the operating temperature is around -10°C, and the back ground will become darker at high temperature operating.

**3-2. ELECTRICAL CHARACTERISTICS**

Item	Symbol	Test Condition	Min.	Typ.	Max.	Unit	
Logic supply Voltage	V <sub>DD</sub>	Ta=25 °C V <sub>DD</sub> =3.0V ± 10%	2.7	3.0	3.3	V	
LCD Drive	V <sub>LCD</sub>		8.7	9.0	9.3	V	
Input Voltage	“H” Level		V <sub>IH</sub>	0.8V <sub>DD</sub>		V <sub>DD</sub>	V
	“L” Level		V <sub>IL</sub>	V <sub>SS</sub>		0.2V <sub>DD</sub>	V
Current Consumption	I <sub>DD</sub>		-	0.50	-	mA	

**3-3. BACKLIGHT****3-3-1. Absolute Maximum Ratings**

Item	Symbol	Condition	Min.	Typ.	Max.	Unit
Forward Current	IF	Ta=25 °C	-	-	60	mA
Reverse Voltage	VR		-	-	5	V
Power Dissipation	PD		-	-	320	mW

**3-3-2. Electrical-optical Characteristics (Ta=25°C)**

Item	Symbol	Condition	Min.		Typ.		Max.		Unit
Forward Voltage	VF	If=60mA Ta=25°C	2.9		3.1		3.3		V
Average Luminous Intensity (measured without LCD panel)	Iv		140		200		-		cd/m <sup>2</sup>
Color coordinates			X	Y	X	Y	X	Y	
		0.24	0.24	0.27	0.27	0.30	0.30		

The brightness is measured without LCD panel

For operation above 25 °C, The I<sub>fm</sub> & P<sub>d</sub> must be derated, the current derating is -0.36mA/ °C for DC drive and -0.86mA/ °C for Pulse drive, the Power dissipation is -0.75mW/ °C. The product working current must not more than the 60% of the I<sub>fm</sub> or I<sub>fp</sub> according to the working temperature.

## 4. TERMINAL FUNCTIONS AND BLOCK DIAGRAM

### 4-1. INTERFACE PIN FUNCTION DESCRIPTION

Pin No.	Pin Name	Function
1	CS1	Chip selection signal
2	RST	Reset signal
3	A0	Select register signal
4	SCL	Serial clock input
5	SDA	Serial data input
6	VDD	Power supply
7	VSS	Ground
8	VOUT	Supply voltage converter input
9	CAP3P	Voltage booster circuit capacitor connection PIN
10	CAP1N	
11	CAP1P	
12	CAP2P	
13	CAP2N	
14-18	V4-V0	Supply voltage for LCD driving

### 4-2. BLOCK DIAGRAM

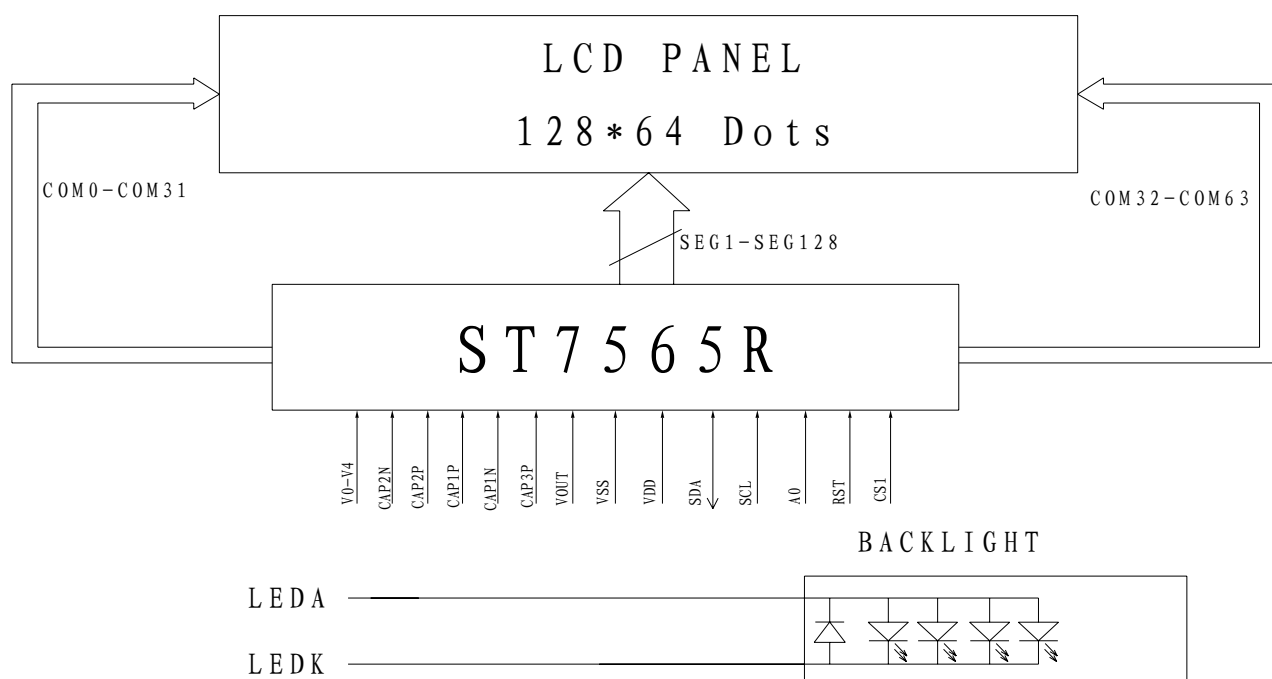

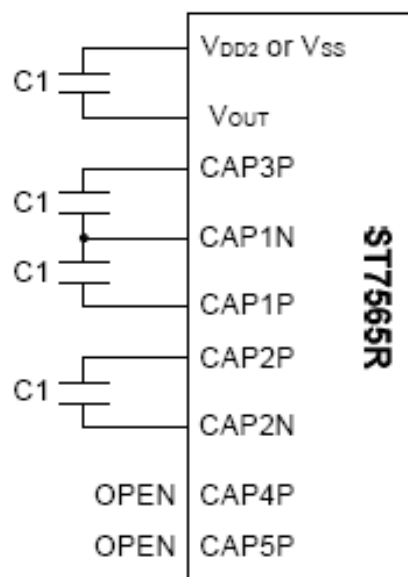

4x voltage booster circuit

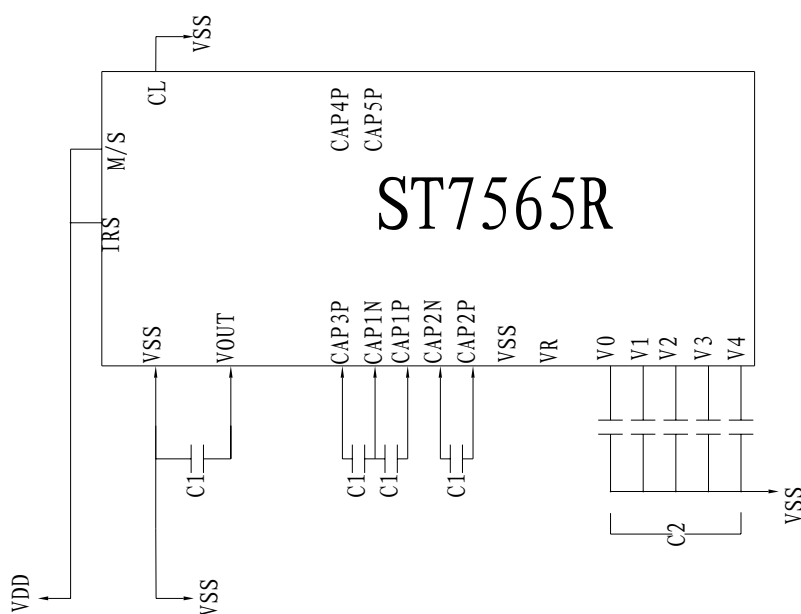
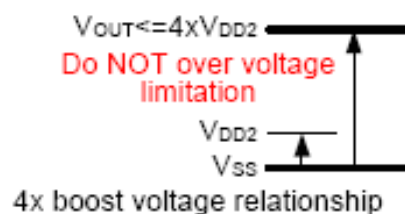

Item	Set value	unit
C1	1 ~ 2.2	uF
C2	0.1 ~ 1	uF

## 5. TIMING CHARACTERISTICS

### The Serial Interface

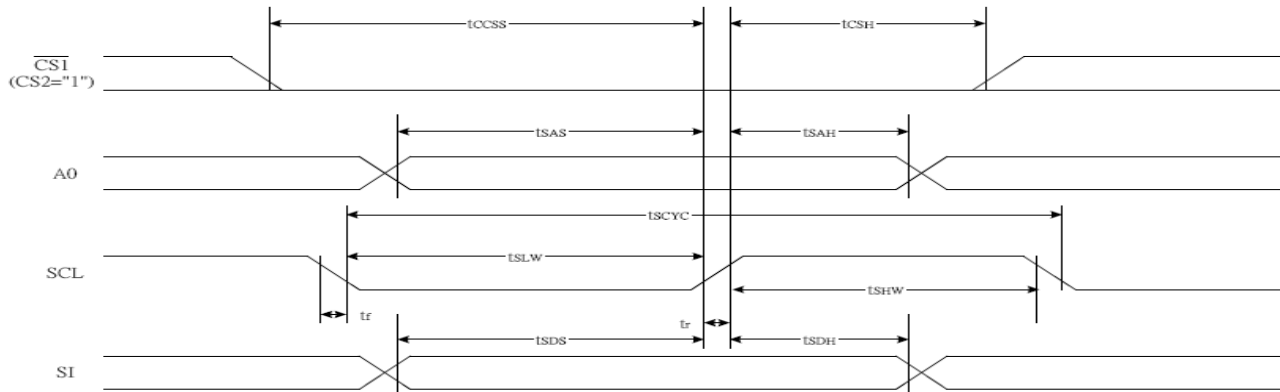

Item	Signal	Symbol	Condition	Rating		Units
				Min.	Max.	
Serial Clock Period	SCL	$T_{scyc}$		100	—	ns
SCL "H" pulse width		$T_{shw}$		50	—	
SCL "L" pulse width		$T_{slw}$		50	—	
Address setup time	A0	$T_{sas}$		30	—	
Address hold time		$T_{сах}$		20	—	
Data setup time	SI	$T_{sds}$		30	—	
Data hold time		$T_{sdh}$		20	—	
CS-SCL time	CS	$T_{css}$		30	—	
CS-SCL time		$T_{csh}$		60	—	

### Reset Timing

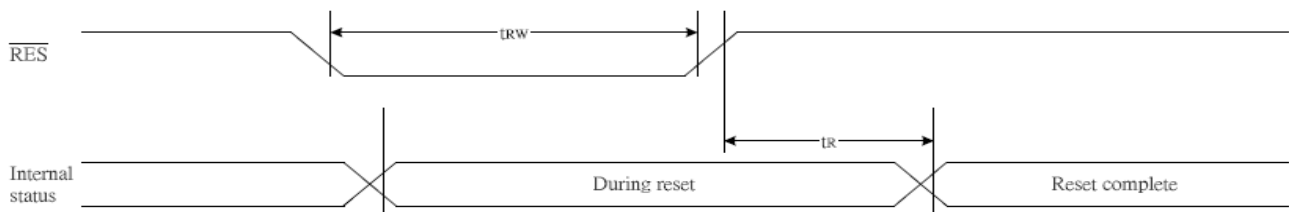

Item	Signal	Symbol	Condition	Rating			Units
				Min.	Typ.	Max.	
Reset time	/RES	$t_r$		—	—	2.0	us
Reset "L" pulse width	/RES	$t_{rw}$		2.0	—	—	us



## 6. INSTRUCTION SET

Command	Command Code										Function		
	A0	/RD	/WR	D7	D6	D5	D4	D3	D2	D1		D0	
(1) Display ON/OFF	0	1	0	1	0	1	0	1	1	1	0	1	
(2) Display start line set	0	1	0	0	1	Display start address						Sets the display RAM display start line address	
(3) Page address set	0	1	0	1	0	1	1	Page address				Sets the display RAM page address	
(4) Column address set upper bit	0	1	0	0	0	0	1	Most significant column address				Sets the most significant 4 bits of the display RAM column address. Sets the least significant 4 bits of the display RAM column address.	
Column address set lower bit	0	1	0	0	0	0	0	Least significant column address					
(5) Status read	0	0	1	Status				0	0	0	0	0	Reads the status data
(6) Display data write	1	1	0	Write data								Writes to the display RAM	
(7) Display data read	1	0	1	Read data								Reads from the display RAM	
(8) ADC select	0	1	0	1	0	1	0	0	0	0	0	1	Sets the display RAM address SEG output correspondence 0: normal, 1: reverse
(9) Display normal/reverse	0	1	0	1	0	1	0	0	1	1	0	1	Sets the LCD display normal/reverse 0: normal, 1: reverse
(10) Display all points ON/OFF	0	1	0	1	0	1	0	0	1	0	0	1	Display all points 0: normal display 1: all points ON
(11) LCD bias set	0	1	0	1	0	1	0	0	0	1	0	1	Sets the LCD drive voltage bias ratio 0: 1/9 bias, 1: 1/7 bias (ST7565R)
(12) Read/modify/write	0	1	0	1	1	1	0	0	0	0	0	0	Column address increment At write: +1 At read: 0
(13) End	0	1	0	1	1	1	0	1	1	1	0	0	Clear read/modify/write
(14) Reset	0	1	0	1	1	1	0	0	0	1	0	0	Internal reset
(15) Common output mode select	0	1	0	1	1	0	0	0	0	*	*	*	Select COM output scan direction 0: normal direction 1: reverse direction
(16) Power control set	0	1	0	0	0	1	0	1	Operating mode				Select internal power supply operating mode
(17) V <sub>0</sub> voltage regulator internal resistor ratio set	0	1	0	0	0	1	0	0	Resistor ratio				Select internal resistor ratio(R <sub>b</sub> /R <sub>a</sub> ) mode
(18) Electronic volume mode set	0	1	0	1	0	0	0	0	0	0	0	1	Set the V <sub>0</sub> output voltage electronic volume register
Electronic volume register set				0	0	Electronic volume value							
(19) Static indicator ON/OFF	0	1	0	1	0	1	0	1	1	0	0	1	0: OFF, 1: ON
Static indicator register set				0	0	0	0	0	0	0	0	0	Mode
(20) Booster ratio set	0	1	0	1	1	1	1	1	0	0	0	0	select booster ratio 00: 2x,3x,4x 01: 5x 11: 6x
(21) Power saver													Display OFF and display all points ON compound command
(22) NOP	0	1	0	1	1	1	0	0	0	1	1	1	Command for non-operation
(23) Test	0	1	0	1	1	1	1	*	*	*	*	*	Command for IC test. Do not use this command

## 7. QUALITY SPECIFICATIONS

### 7-1. LCM Appearance and Electric inspection Condition

1. Inspection will be done by placing LCM 30cm away from inspector's eyeballs under normal illumination.

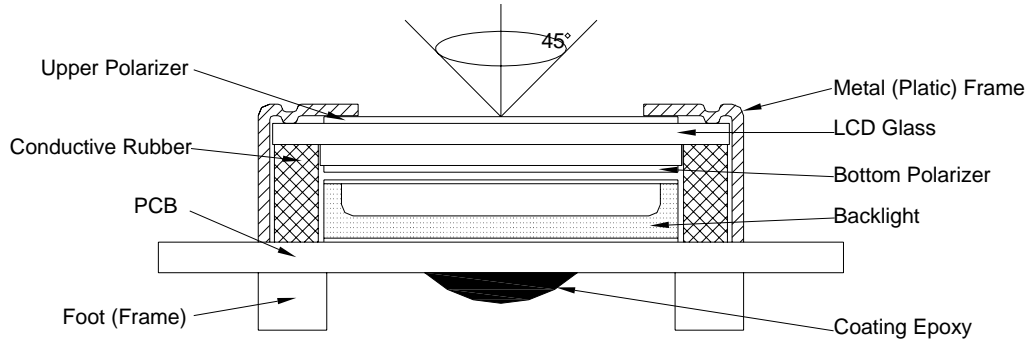

2. View Angle: with in 45° around perpendicular line.

### 7-2. Definition

#### 1. COB

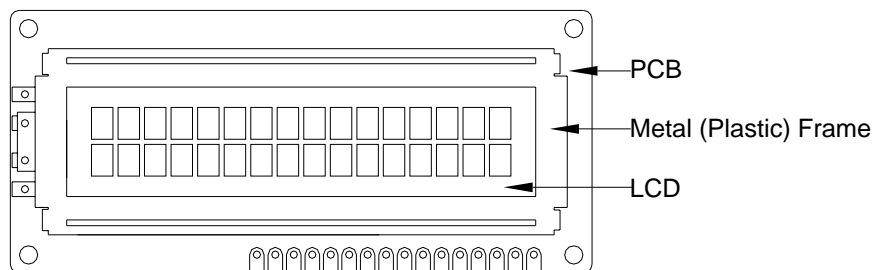

#### 2. Heat Seal

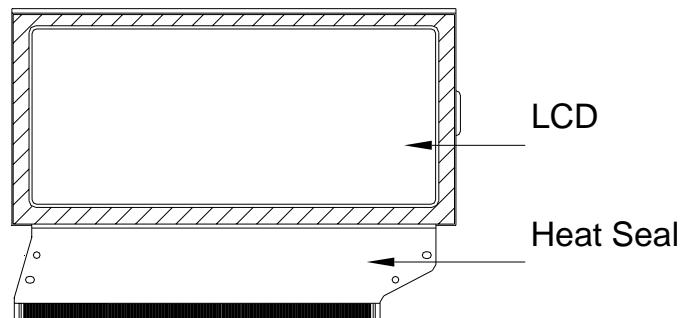

#### 3. TAB and COG

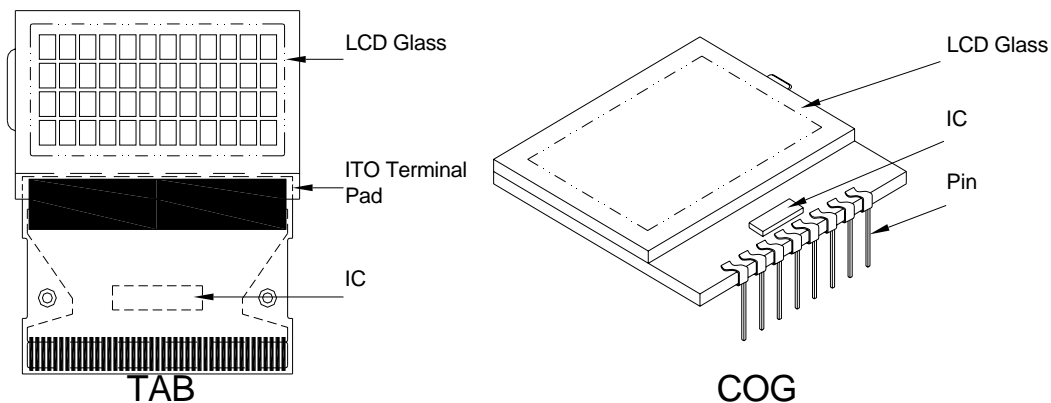

**7-3. Sampling Plan and Acceptance**

- Sampling Plan  
MIL - STD - 105E ( || ) ordinary single inspection is used.
- Acceptance  
Major defect: AQL = 0.65%  
Minor defect: AQL = 1.5%

**7-4. Criteria****1. COB**

Defect	Inspection Item	Inspection Standards	
Major	PCB copper flakes peeling off	Any copper flake in viewing Area should be greater than 1.0mm <sup>2</sup>	Reject
Major	Height of coating epoxy	Exceed the dimension of drawing	Reject
Major	Void or hole of coating epoxy	Expose bonding wire or IC	Reject
Major	PCB cutting defect	Exceed the dimension of drawing	Reject

**2. SMT**

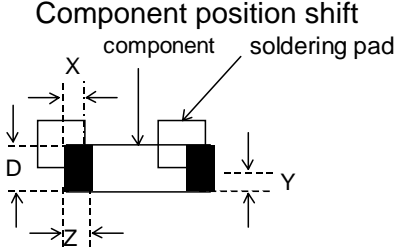
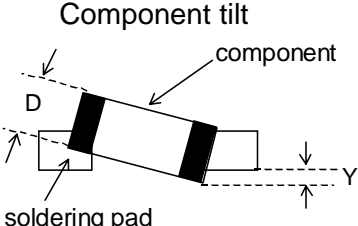
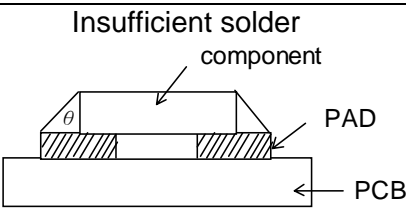
Defect	Inspection Item	Inspection Standards	
Minor	Component marking not readable		Reject
Minor	Component height	Exceed the dimension Of drawing	Reject
Major	Component solder defect (missing , extra, wrong component or wrong orientation)		Reject
Minor	Component position shift 	$X < 3/4Z$ $Y > 1/3D$	Reject
Minor	Component tilt 	$Y > 1/3D$	Reject
Minor	Insufficient solder 	$\theta \leq 20^\circ$	Reject

**3. Metal (Plastic) Frame**

Defect	Inspection Item	Inspection Standards		
Major	Crack / breakage	Anywhere		Reject
Minor	Frame Scratch	W	L	Acceptable of Scratch
		$w < 0.1\text{mm}$	Any	Ignore
		$0.1 \leq w < 0.2\text{mm}$	$L \leq 5.0\text{mm}$	2
		$0.2 \leq w < 0.3\text{mm}$	$L \leq 3.0\text{mm}$	1
		$w \geq 0.3\text{mm}$	Any	0
Note: 1. Above criteria applicable to scratch lines with distance greater than 5mm. 2. Scratch on the back side of frame (not visible) can be ignored.				
Minor	Frame Dent , Prick $\Phi = \frac{L + W}{2}$			Acceptable of Dents / Pricks
		$\Phi \leq 1.0\text{mm}$		2
		$1.0 < \Phi \leq 1.5\text{mm}$		1
		$1.5\text{mm} < \Phi$		0
Note : 1. Above criteria applicable to any two dents / pricks with distance greater than 5mm 2. Dent / prick on the back side of frame (not visible) can be ignored				
Minor	Frame Deformation	Exceed the dimension of drawing		
Minor	Metal Frame Oxidation	Any rust		

**4. Flexible Film Connector (FFC)**

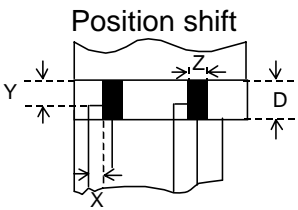
Defect	Inspection Item	Inspection Standards	
Minor	Tilted soldering	Within the angle $+5^\circ$	Acceptable
Minor	Uneven solder joint /bump		Reject
Minor	Hole $\Phi = \frac{L + W}{2}$	Expose the conductive line	Reject
		$\Phi > 1.0\text{mm}$	Reject
Minor		$Y > 1/3D$	Reject
		$X > 1/2Z$	Reject

**5. Screw**

Defect	Inspection Item	Inspection Standards	
Major	Screw missing/loosen		Reject
Minor	Screw oxidation	Any rust	Reject
Minor	Screw deformation	Difficult to accept screw driver	Reject

**6. Heatseal 、TCP 、FPC**

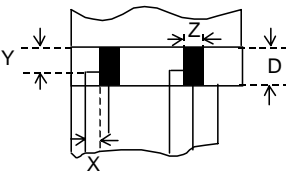
Defect	Inspection Item	Inspection Standards	
Major	Scratch expose conductive layer		Reject
Minor	HS Hole $\Phi = \frac{L+W}{2}$	$\Phi > 0.5\text{mm}$	Reject
Major	Adhesion strength	Less than the specification	Reject
Minor	Position shift 	$Y > 1/3D$	Reject
		$X > 1/2Z$	Reject
Major	Conductive line break		Reject

**7. LED 、 Backing Protective Film and Others**

Defect	Inspection Item	Inspection Standards	
Minor	LED dirty, prick	Acceptable number of units	
		$\Phi \leq 0.10\text{mm}$	ignore
		$0.10 < \Phi \leq 0.15\text{mm}$	2
		$0.15 < \Phi \leq 0.2\text{mm}$	1
		$\Phi > 0.2\text{mm}$	0
		The distance between any two spots should be $\geq 5\text{mm}$ Any spot/dot/void outside of viewing area is acceptable	
Minor	Protective film tilt	Not fully cover LCD	Reject
Major	COG coating	Not fully cover ITO circuit	Reject

**8. Electric Inspection**

Defect	Inspection Item	Inspection Standards	
Major	Short		Reject
Major	Open		Reject

**9. Inspection Specification of LCD**

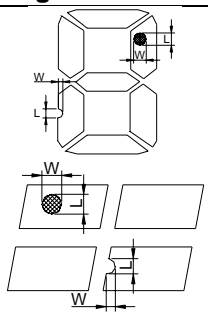
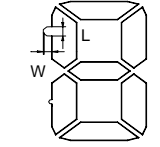
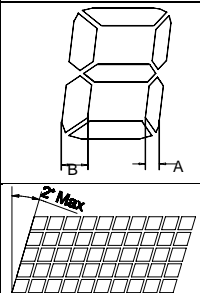
Defect	Inspect Item	Inspection Standards				
		W	W≤0.03	0.03<W≤0.05	W>0.05	
Minor	Linear Defect * Glass Scratch * Polarizer Scratch * Fiber and Linear material	L	L<5	L<3	Any	
		ACC. NO.	1	1	Reject	
		Note	L is the length and W is the width of the defect			
Minor	Black Spot and Polarizer Pricked * Foreign material between glass and polarizer or glass and glass * Polarizer hole or protuberance by external force	Φ	Φ≤0.1	0.1<Φ≤0.15	0.15<Φ≤0.2	Φ>0.2
		ACC. NO.	3EA / 100mm <sup>2</sup>	2	1	0
		Note	Φ is the average diameter of the defect. Distance between two defects > 10mm.			
Minor	White Spot and Bubble in polarizer * Unobvious transparent foreign material between glass and glass or glass and polarizer * Air protuberance between polarizer and glass	Φ	Φ≤0.3	0.3<Φ≤0.5	0.5<Φ	
		ACC. NO.	3EA / 100mm <sup>2</sup>	1	0	
		Note	Φ is the average diameter of the defect. Distance between two defects > 10mm.			
Minor	Segment Defect 	Φ	Φ≤0.10	0.10<Φ≤0.20	0.20<Φ≤0.25	Φ>0.25
		ACC. NO.	3EA / 100mm <sup>2</sup>	2	1	0
		Note	W is more than 1/2 segment width			Reject
			$\Phi = \frac{L + W}{2}$ Distance between two defect is 10mm			
Minor	Protuberant Segment  $\Phi = (L + W) / 2$	Φ	Φ≤0.10	0.10<Φ≤0.20	0.20<Φ≤0.25	Φ>0.25
		W	Glue	W≤1/2 Seg W<0.2	W≤1/2 Seg W<0.2	Ignore
		ACC. NO.	3EA / 100mm <sup>2</sup>	2	1	0
Minor	Assembly Mis-alignment 	1. Segment				
		B	B≤0.4mm	0.4<B≤1.0mm	B>1.0mm	
		B-A	B-A<1/2B	B-A<0.2	B-A<0.25	
		Judge	Acceptable	Acceptable	Acceptable	
		2. Dot Matrix				
		Deformation>2°			Reject	
Minor	Stain on LCD Panel Surface	Accept when stains can be wiped lightly with a soft cloth or a similar one. Otherwise, judged according to the above items: "Black spot" and "White Spot"				

**8. RELIABILITY**

NO.	Item	Condition	Criterion
1	High Temperature Operating	70°C, 96Hrs	No defect in cosmetic and operational function allowable.
2	Low Temperature Operating	-20°C, 96Hrs	
3	High Humidity	50°C, 90%RH, 96Hrs	
4	High Temperature Storage	80°C, 96Hrs	
5	Low Temperature Storage	-30°C, 96Hrs	
6	Vibration	Random wave 10 ~ 100Hz Acceleration: 2g 2 Hrs per direction(X,Y,Z)	Total current Consumption should be below double of initial value.
7	Thermal Shock	-20°C to 25°C to 70°C (60Min) (5Min) (60Min) 16Cycles	
8	ESD Testing	Contract Discharge Voltage: +1 ~ 5kV and -1 ~ -5kV  Air Discharge Voltage: +1 ~ 8kV and -1 ~ -8kV	There will be discharged ten times at every discharging voltage cycle. The voltage gap is 1kV.

Note: 1) Above conditions are suitable for our company standard products.

2) For restrict products, the test conditions listed as above must be revised.

## 9. HANDLING PRECAUTION

### (1) Mounting Method

The panel of the LCD Module consists of two thin glass plates with polarizers, which easily get damaged. Since the Module is fixed by utilizing fitting holes in the printed circuit board.

Extreme care should be taken when handling the LCD Modules.

### (2) Caution of LCD handling & cleaning

When cleaning the display surface, use soft cloth with solvent (recommended below) and wipe lightly.

- Isopropyl alcohol
- Ethyl alcohol
- Tricolors triflers' thane

Do not wipe the display surface with dry or hard materials that will damage the polarizer surface.

Do not use the following solvent:

- Water- Keton- Aromatics

### (3) Caution against static charge

The LCD Module use C-MOS LSI drivers, so we recommend that you connect any unused input terminal to VDD or VSS, do not input any signals before power is turned on. And ground your body, Work/assembly table. And assembly equipment to protect against static electricity.

### (4) Packaging

- Modules use LCD elements, and must be treated as such. Avoid intense shock and falls from a height.
- To prevent modules from degradation. Do not operate or store them exposed directly to sunshine or high temperature/humidity.

### (5) Caution for operation

- It is indispensable to drive LCD's within the specified voltage limit since the higher voltage than the limit shortens LCD life. An electrochemical reaction due to direct current causes LCD deterioration, Avoid the use of direct current drive.
- Response time will be extremely delayed at lower temperature than the operating temperature range and on the other hand at higher temperature LCD's show dark color in them. However those phenomena do not mean malfunction or out of order with LCD's, which will come back in the specified operating temperature range.
- If the display area is pushed hard during operation, some font will be abnormally displayed but it resumes normal condition after turning off once.
- A slight dew depositing on terminals is a cause for electro-chemical reaction resulting in terminal open circuit.

Usage under the relative condition of 40°C, 50%RH or less is required.

### (6) Storage

In the case of storing for a long period of time (for instance.) For years) for the purpose or replacement use, the following ways are recommended.

- Storage in a polyethylene bag with sealed so as not to enter fresh air outside in it, And with no desiccant.
- Placing in a dark place where neither exposure to direct sunlight nor light is. Keeping temperature in the specified storage temperature range.
- Storing with no touch on polarizer surface by the anything else. (It is recommended to store them as they have been contained in the inner container at the time of delivery)

### (7) Safety

- It is recommendable to crash damaged or unnecessary LCD into pieces and wash off liquid crystal by using solvents such as acetone and ethanol. Which should be burned up later.
- When any liquid crystal leaked out of a damaged glass cell comes in contact with your hands, please wash it off well with soap and water.



# 10. OUTLINE DIMENSION

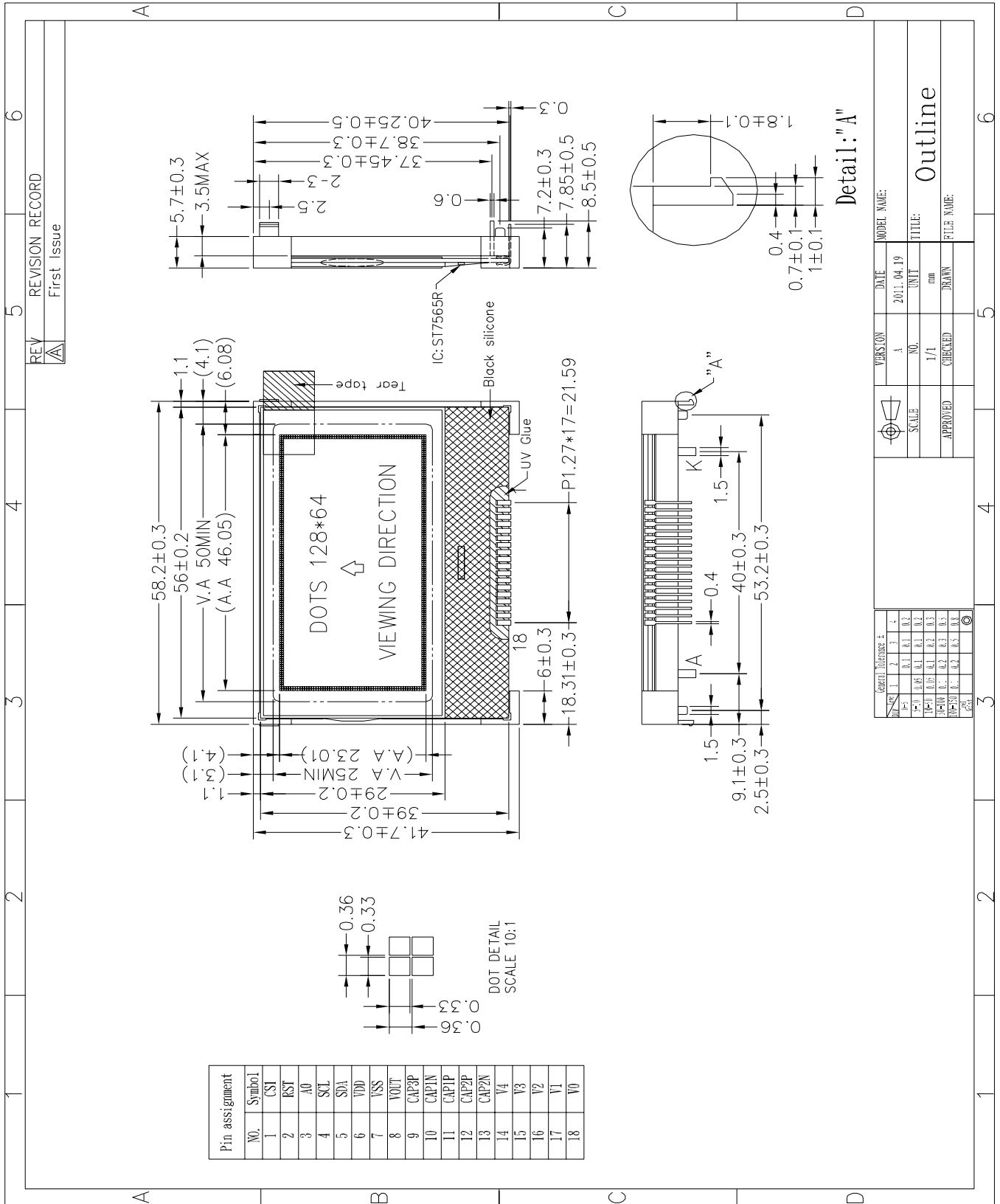

REV	REVISION RECORD
A	First Issue

VERSION	DATE	MODEL NAME
A	2011.04.19	

SCALE	UNIT	TITLE
1/1	mm	Outline

APPROVED	CHECKED	DRAWN	FILE NAME