



PRODUCT SPECIFICATION

MONO LCD MODULE MODEL: G1206B4SGW6G-A0 Ver:1.0

< ◇ > Preliminary Specification

< ◆ > Finally Specification

CUSTOMER'S APPROVAL	
CUSTOMER :	
SIGNATURE:	DATE:

APPROVED BY	PM REVIEWED	PD REVIEWED	PREPARED BY

Revision Status

Version	Revise Date	Page	Content	Modified By
Ver. 1.0	2011.02.19		First Issued	

Table of Contents

No.	Contents	Page
1.	FEATURES.....	4
2.	MECHANICAL SPECIFICATIONS	4
3.	ELECTRICAL SPECIFICATIONS	4
4.	TERMINAL FUNCTIONS AND BLOCK DIAGRAM	6
5.	TIMING CHARACTERISTICS	7
6.	COMMAND LIST	8
7.	QUALITY SPECIFICATIONS	9
8.	RELIABILITY	14
9.	HANDLING PRECAUTION	15
10.	OUTLINE DIMENSION	16

1. Features

The features of LCD are as follows

- * Display mode : STN/BLUE/ Transmissive/Negative
- * Controller IC : NT7538
- * Interface Input Data : 8080 interface
- * Driving Method : 1/65Duty, 1/9Bias
- * Viewing Direction : 6 O'clock
- * Backlight : Edge white
- * Sample NO. : G1206B4SGW6G-A0_01/20110218

2. MECHANICAL SPECIFICATIONS

Item	Specification	Unit
Module Size	80.5(W) x 45(H) x 5.3(D)	mm
Number of Dots	128 x 64	Dots
View display area	60MIN(W) x 32.6MIN(H)	mm
Activity Display Area	55.01(W) x 27.49(H)	mm
Dot Size	0.4(W) x 0.4(H)	mm
Dot Pitch	0.43(W) x 0.43(H)	mm

3. ELECTRICAL SPECIFICATIONS

3-1 ABSOLUTE MAXIMUM RATINGS (Ta = 25 °C)

Item	Symbol	Standard Value			Unit
		Min.	Typ.	Max.	
Supply Voltage For Logic	V _{DD} – V _{SS}	-0.3	-	4.0	V
Supply Voltage For LCD Drive	V _{LCD}	-0.3	-	15	V
Input Voltage	V _{in}	-0.3	-	V _{DD} +0.3	V
Operating Temp.	T _{op}	-20	-	+70	°C
Storage Temp.	T _{st}	-30	-	+80	°C

*. NOTE: The response time will be extremely slow when the operating temperature is around -10°C, and the back ground will become darker at high temperature operating.

3-2 ELECTRICAL CHARACTERISTICS

Item	Symbol	Test Condition	Min.	Typ.	Max.	Unit	
Logic supply Voltage	$V_{DD} - V_{SS}$	$T_a = 25\text{ }^\circ\text{C}$ $V_{DD}=3\text{V} \pm 10\%$	2.6	3.0	3.3	V	
LCD Drive	V_{LCD}		7.3	7.6	7.9	V	
Input Voltage	"H" Level		V_{IH}	$0.8V_{DD}$	-	V_{DD}	V
	"L" Level		V_{IL}	V_{SS}	-	$0.2V_{DD}$	V
Frame Frequency	f_{FLM}		-	84.3	-	Hz	
Current Consumption	I_{DD}		-	0.54	-	mA	

3-3. BACKLIGHT

3-3-1. Absolute Maximum Ratings

Item	Symbol	Condition	Min.	Typ.	Max.	Unit
Forward Current	IF	$T_a = 25\text{ }^\circ\text{C}$	-	-	60	mA
Reverse Voltage	VR		-	-	5	V
Power Dissipation	PD		-	-	186	mW

3-3-2. Electrical-optical Characteristics

Item	Symbol	Condition	Min.		Typ.		Max.		Unit
Forward Voltage	VF	$I_f=60\text{mA}$ $T_a = 25\text{ }^\circ\text{C}$	2.8		3.1		3.2		V
Average Luminous Intensity	I_v		210		300		-		cd/m^2
Color Coordinates	-		X	Y	X	Y	X	Y	
			0.27	0.27			0.33	0.33	

The brightness is measured without LCD panel

4. TERMINAL FUNCTIONS AND BLOCK DIAGRAM

4-1. INTERFACE PIN FUNCTION DESCRIPTION

PIN NO.	SYMBOL	FUNCIONS
1	/CS1	Chip selection signal
2	/RES	Reset signal
3	AO	Select register signal
4	WR	Write enable signal
5	RD	Enable signal
6-13	D0-D7	Data bus line
14	VDD	Supply voltage for logical circuit
15	VSS	Ground (0V)
16	VOUT	Supply voltage for the liquid crystal drive.
17	CAP1-	DC/DC voltage converter. Connect C1 between them.
18	CAP1+	
19	CAP2+	
20	CAP2-	
21-24	V1-V4	A multi-level power supply for the liquid crystal drive.
25	V0	
26	VR	Voltage adjustment pad
27	LCD_ID	VSS
28	IRS	Selects the resistors for the V0 voltage level adjustment

4-2. BLOCK DIAGRAM

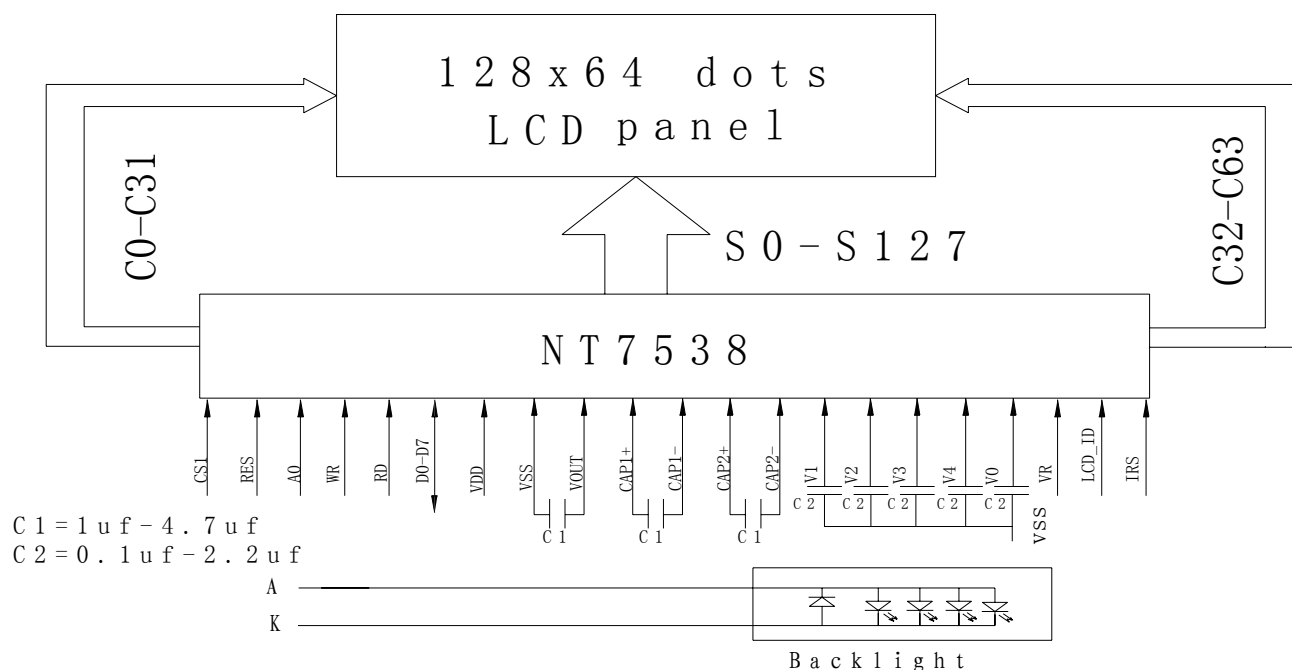

5. TIMING CHARACTERISTICS

5-1. System Buses Read/Write Characteristics (for 8080 Series MPU)

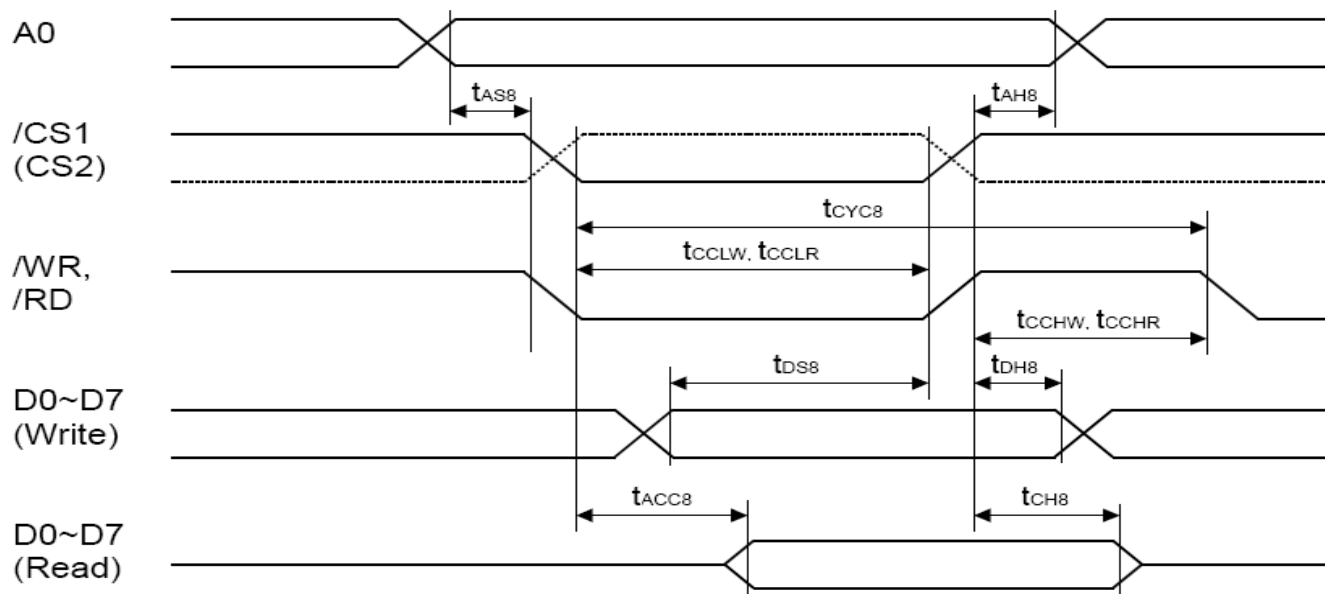

Symbol	Parameter	Min.	Typ.	Max.	Unit	Condition
T_{AH8}	Address hold time	0	-	-	ns	A0
T_{AS8}	Address setup time	0	-	-	ns	
t_{CYC8}	System cycle time	240	-	-	ns	
t_{CCLW}	Control low pulse width (write)	90	-	-	ns	/WR
t_{CCLR}	Control low pulse width (read)	120	-	-	ns	/RD
t_{CCHW}	Control high pulse width (write)	100	-	-	ns	/WR
t_{CCHR}	Control high pulse width (read)	60	-	-	ns	/RD
T_{DS8}	Data setup time	40	-	-	ns	D0~D7
T_{DH8}	Data hold time	0	-	-	ns	
t_{ACC8}	/RD access time	-	-	140	ns	D0~D7, CL = 100pF
T_{CH8}	Output disable time	5	-	50	ns	

5-2. Reset Timing

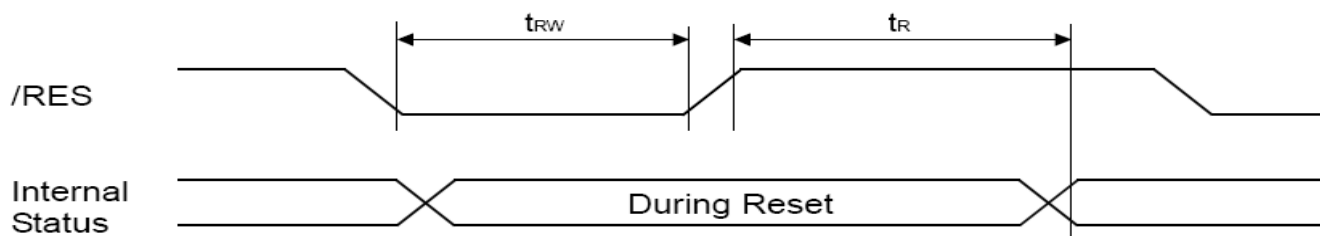

Symbol	Parameter	Min.	Typ.	Max.	Unit	Condition
t_R	Reset Time	-	-	1.0	μ s	
t_{RW}	Reset low pulse width	10	-	-	μ s	/RES

6. COMMAND LIST

6-1. command table

Command	A0	/RD	/WR	Code								Hex	Function	
				D7	D6	D5	D4	D3	D2	D1	D0			
(1) Display OFF	0	1	0	1	0	1	0	1	1	1	0	1	A Eh A Fh	Turn on LCD panel when high, and turn off when low
(2) Display Start Line Set	0	1	0	0	1	Display Start Address					40h to 7Fh	Specifies RAM display line for COM0		
(3) Page Address Set	0	1	0	1	0	1	1	Page Address				B0h to B8h	Set the display data RAM page in Page Address register	
(4) Column Address Set	0	1	0	0	0	0	1	Higher Column Address			00h to 18h	Set 4 higher bits and 4 lower bits of column address of display data RAM in register		
	0	1	0	0	0	0	0	Lower Column Address						
(5) Read Status	0	0	1	Status				0	0	0	0	XX	Reads the status information	
(6) Write Display Data	1	1	0	Write Data								XX	Write data in display data RAM	
(7) Read Display Data	1	0	1	Read Data								XX	Read data from display data RAM	
(8) ADC Select	0	1	0	1	0	1	0	0	0	0	0	1	A0h A1h	Set the display data RAM address SEG output correspondence
(9) Normal/Reverse Display	0	1	0	1	0	1	0	0	1	1	0	1	A6h A7h	Normal indication when low, but full indication when high
(10) Entire Display ON/OFF	0	1	0	1	0	1	0	0	1	0	0	1	A4h A5h	Select normal display (0) or entire display on
(11) LCD Bias Set	0	1	0	1	0	1	0	0	0	1	0	1	A2h A3h	Sets LCD driving voltage bias ratio
(12) Read-Modify-Write	0	1	0	1	1	1	0	0	0	0	0	0	E0h	Increments column address counter during each write
(13) End	0	1	0	1	1	1	0	1	1	1	0	0	E Eh	Releases the Read-Modify-Write
(14) Reset	0	1	0	1	1	1	0	0	0	1	0	0	E2h	Resets internal functions
(15) Common Output Mode Select	0	1	0	1	1	0	0	0	1	*	*	*	C0h to C Fh	Select COM output scan direction *: invalid data
(16) Power Control Set	0	1	0	0	0	1	0	1	Operation Status			28h to 2Fh	Select the power circuit operation mode	
(17) V0 Voltage Regulator Internal Resistor ratio Set	0	1	0	0	0	1	0	0	Resistor Ratio			20h to 27h	Select internal resistor ratio Rb/Ra mode	
(18) Electronic Volume mode Set Electronic Volume Register Set	0	1	0	1	0	0	0	0	0	0	1	81h		
	0	1	0	*	*	Electronic Control Value					XX	Sets the V0 output voltage electronic volume register		
(19) Set Static indicator ON/OFF Set Static Indicator Register	0	1	0	1	0	1	0	1	1	0	0	1	A Ch A Dh	Sets static indicator ON/OFF 0: OFF, 1: ON
	0	1	0	*	*	*	*	*	*	Mode		XX	Sets the flash mode	
(20) Power Save	0	1	0	-	-	-	-	-	-	-	-	-	-	Compound command of Display OFF and Entire Display ON
(21) NOP	0	1	0	1	1	1	0	0	0	1	1	1	E3h	Command for non-operation
(22) Oscillation Frequency Select	0	1	0	1	1	1	0	0	1	0	0	1	E4h E5h	Select the oscillation frequency
(23) Partial Display mode Set	0	1	0	1	0	0	0	0	0	1	0	1	82h 83h	Enter/Release the partial display mode
(24) Partial Display Duty Set	0	1	0	0	0	1	1	0	Duty Ratio			30h 37h	Sets the LCD duty ratio for partial display mode	
(25) Partial Display Bias Set	0	1	0	0	0	1	1	1	Bias Ratio			38h 3Fh	Sets the LCD bias ratio for partial display mode	
(26) Partial Start Line Set Partial Start Line Set	0	1	0	1	1	0	1	0	0	1	1	D3h	Enter Partial Start Line Set	
	0	1	0	1	1	Partial Start Line					XX	Sets the LCD Number of partial display start line		
(27) N-Line Inversion Set Number of Line Set	0	1	0	1	0	0	0	0	1	0	1	85h	Enter N-Line inversion	
	0	1	0	*	*	*	Number of Line					XX	Sets the number of line used for N-Line inversion	
(28) N-Line Inversion Release	0	1	0	1	0	0	0	0	1	0	0	84h	Exit N-Line Inversion	
(29) DC/DC Clock Set DC/DC Clock Division Set	0	1	0	1	1	1	0	0	1	1	0	E6h	Set DC/DC Clock Frequency	
	0	1	0	1	1	0	0	Clock Division			XX	Set the Division of DC/DC Clock Frequency		
(30) Test Command	0	1	0	1	1	1	1	*	*	*	*	F1h to F Fh	IC test command. Do not use!	
(31) Test Mode Reset	0	1	0	1	1	1	1	0	0	0	0	F0h	Command of test mode reset	

7. QUALITY SPECIFICATIONS

7 - 1. LCM Appearance and Electric inspection Condition

1. Inspection will be done by placing LCM 30cm away from inspector's eyeballs under normal illumination.

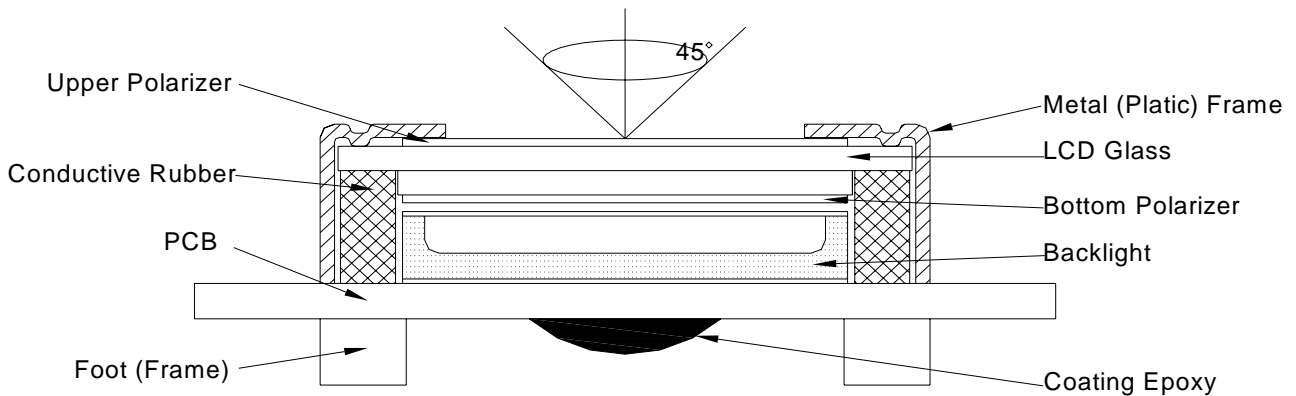

2. View Angle: with in 45° around perpendicular line.

7- 2. Definition

1. COB

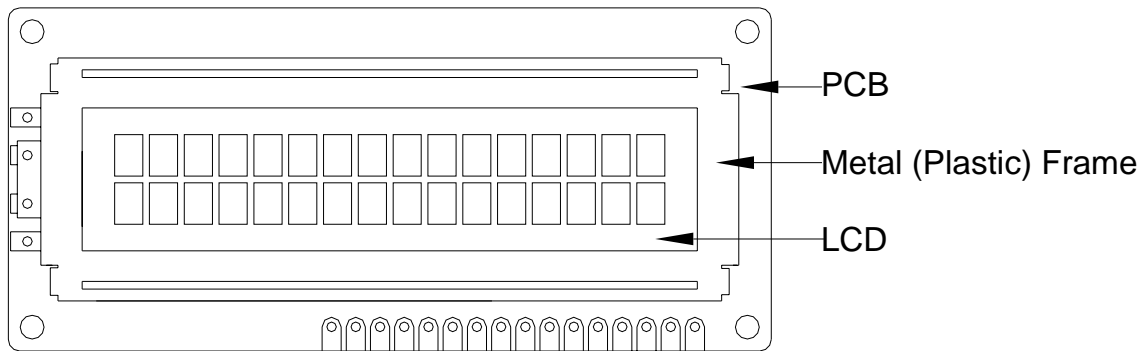

2. Heat Seal

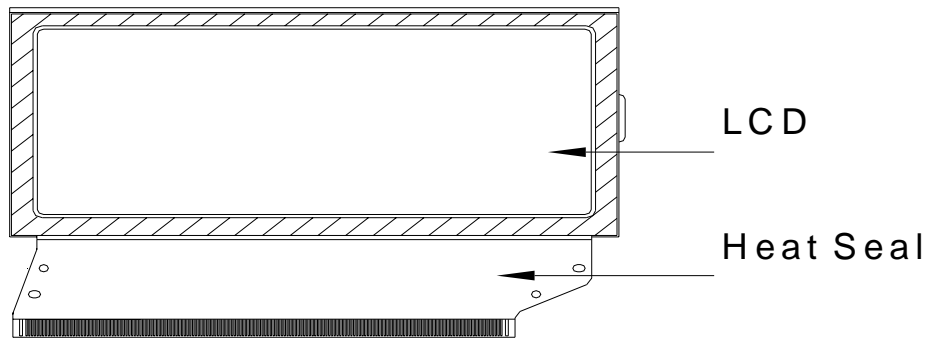

3. TAB and COG

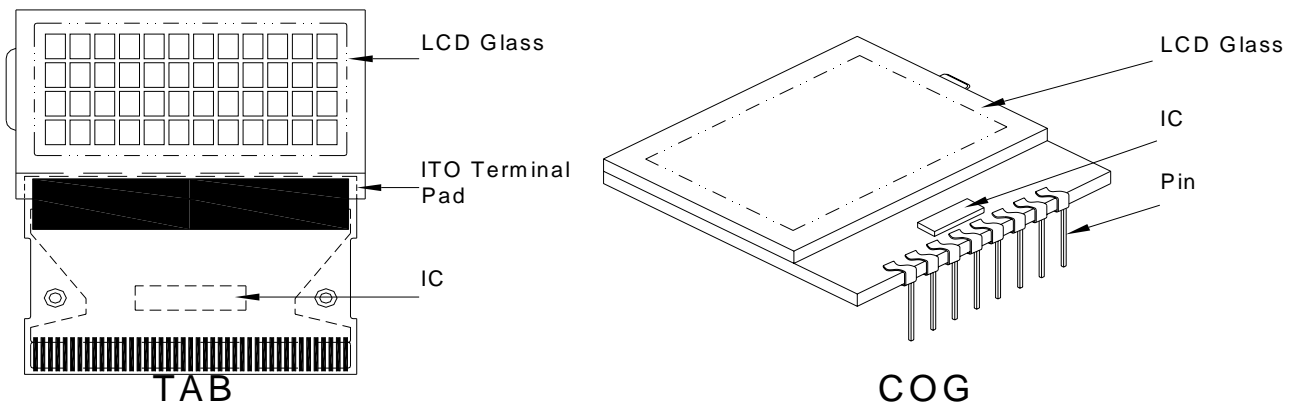

7-3. Sampling Plan and Acceptance

1. Sampling Plan

MIL - STD - 105E (||) ordinary single inspection is used.

2. Acceptance

Major defect: AQL = 0.65%

Minor defect: AQL = 1.5%

7-4. Criteria**1. COB**

Defect	Inspection Item	Inspection Standards	
Major	PCB copper flakes peeling off	Any copper flake in viewing Area should be greater than 1.0mm ²	Reject
Major	Height of coating epoxy	Exceed the dimension of drawing	Reject
Major	Void or hole of coating epoxy	Expose bonding wire or IC	Reject
Major	PCB cutting defect	Exceed the dimension of drawing	Reject

2. SMT

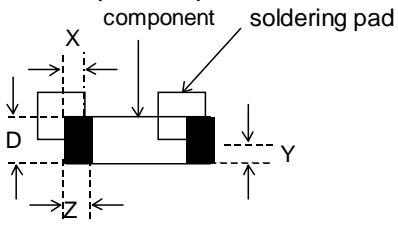
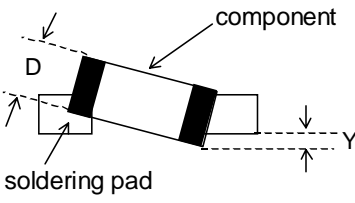
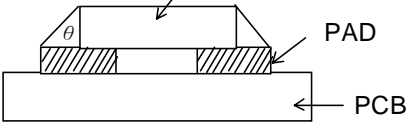
Defect	Inspection Item	Inspection Standards	
Minor	Component marking not readable		Reject
Minor	Component height	Exceed the dimension Of drawing	Reject
Major	Component solder defect (missing , extra, wrong component or wrong orientation)		Reject
Minor	Component position shift 	$X < 3/4Z$ $Y > 1/3D$	Reject Reject
Minor	Component tilt 	$Y > 1/3D$	Reject
Minor	Insufficient solder 	$\theta \leq 20^\circ$	Reject

3. Metal (Plastic) Frame

Defect	Inspection Item	Inspection Standards	
Major	Crack / breakage	Anywhere	
Minor	Frame Scratch	W	L
		$w < 0.1\text{mm}$	Any
		$0.1 \leq w < 0.2\text{mm}$	$L \leq 5.0\text{mm}$
		$0.2 \leq w < 0.3\text{mm}$	$L \leq 3.0\text{mm}$
		$w \geq 0.3\text{mm}$	Any
		Note : 1. Above criteria applicable to scratch lines with distance greater than 5mm. 2. Scratch on the back side of frame (not visible) can be ignored .	
Minor	Frame Dent , Prick $\Phi = \frac{L + W}{2}$		Acceptable of Dents / Pricks
		$\Phi \leq 1.0\text{mm}$	2
		$1.0 < \Phi \leq 1.5\text{mm}$	1
		$1.5\text{mm} < \Phi$	0
Note : 1. Above criteria applicable to any two dents / pricks with distance greater than 5mm 2. Dent / prick on the back side of frame (not visible) can be ignored			
Minor	Frame Deformation	Exceed the dimension of drawing	
Minor	Metal Frame Oxidation	Any rust	

4. Flexible Film Connector (FFC)

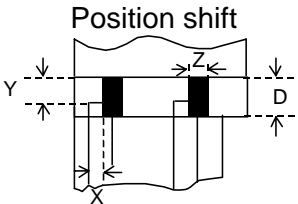
Defect	Inspection Item	Inspection Standards	
Minor	Tilted soldering	Within the angle $+5^\circ$	Acceptable
Minor	Uneven solder joint /bump		Reject
Minor	Hole $\Phi = \frac{L + W}{2}$	Expose the conductive line	Reject
		$\Phi > 1.0\text{mm}$	Reject
Minor	 <p>Position shift</p>	$Y > 1/3D$	Reject
		$X > 1/2Z$	Reject

5. Screw

Defect	Inspection Item	Inspection Standards	
Major	Screw missing/loosen		Reject
Minor	Screw oxidation	Any rust	Reject
Minor	Screw deformation	Difficult to accept screw driver	Reject

6. Heatseal 、TCP 、FPC

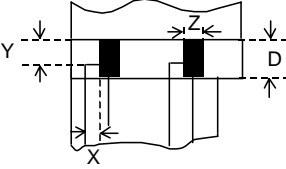
Defect	Inspection Item	Inspection Standards	
Major	Scratch expose conductive layer		Reject
Minor	HS Hole $\Phi = \frac{L+W}{2}$	$\Phi > 0.5\text{mm}$	Reject
Major	Adhesion strength	Less than the specification	Reject
Minor	Position shift 	$Y > 1/3D$	Reject
		$X > 1/2Z$	Reject
Major	Conductive line break		Reject

7. LED Backing Protective Film and Others

Defect	Inspection Item	Inspection Standards	
Minor	LED dirty, prick	Acceptable number of units	
		$\Phi \leq 0.10\text{mm}$	Ignore
		$0.10 < \Phi \leq 0.15\text{mm}$	2
		$0.15 < \Phi \leq 0.2\text{mm}$	1
		$\Phi > 0.2\text{mm}$	0
		The distance between any two spots should be $\geq 5\text{mm}$ Any spot/dot/void outside of viewing area is acceptable	
Minor	Protective film tilt	Not fully cover LCD	Reject
Major	COG coating	Not fully cover ITO circuit	Reject

8. Electric Inspection

Defect	Inspection Item	Inspection Standards	
Major	Short		Reject
Major	Open		Reject

9. Inspection Specification of LCD

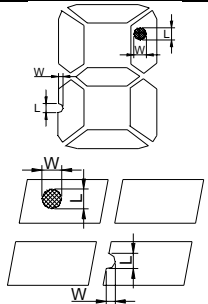
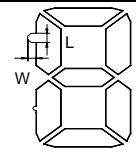
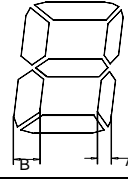
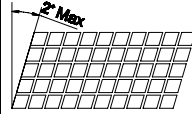
Defect	Inspect Item	Inspection Standards				
		W	$W \leq 0.03$	$0.03 < W \leq 0.05$	$W > 0.05$	
Minor	Linear Defect * Glass Scratch * Polarizer Scratch * Fiber and Linear material	L	$L < 5$	$L < 3$	Any	
		ACC. NO.	1	1	Reject	
		Note	L is the length and W is the width of the defect			
Minor	Black Spot and Polarizer Pricked * Foreign material between glass and polarizer or glass and glass * Polarizer hole or protuberance by external force	Φ	$\Phi \leq 0.1$	$0.1 < \Phi \leq 0.15$	$0.15 < \Phi \leq 0.2$	$\Phi > 0.2$
		ACC. NO.	3EA / 100mm ²	2	1	0
		Note	Φ is the average diameter of the defect. Distance between two defects > 10mm.			
Minor	White Spot and Bubble in polarizer * Unobvious transparent foreign material between glass and glass or glass and polarizer * Air protuberance between polarizer and glass	Φ	$\Phi \leq 0.3$	$0.3 < \Phi \leq 0.5$	$0.5 < \Phi$	
		ACC. NO.	3EA / 100mm ²	1	0	
		Note	Φ is the average diameter of the defect. Distance between two defects > 10mm.			
Minor	Segment Defect 	Φ	$\Phi \leq 0.10$	$0.10 < \Phi \leq 0.20$	$0.20 < \Phi \leq 0.25$	$\Phi > 0.25$
		ACC. NO.	3EA / 100mm ²	2	1	0
		Note	W is more than 1/2 segment width			Reject
			$\Phi = \frac{L + W}{2}$ Distance between two defect is 10mm			
Minor	Protuberant Segment  $\Phi = (L + W) / 2$	Φ	$\Phi \leq 0.10$	$0.10 < \Phi \leq 0.20$	$0.20 < \Phi \leq 0.25$	$\Phi > 0.25$
		W	Glue	$W \leq 1/2$ Seg $W \leq 0.2$	$W \leq 1/2$ Seg $W \leq 0.2$	Ignore
		ACC. NO.	3EA / 100mm ²	2	1	0
Minor	Assembly Mis-alignment  	1. Segment				
		B	$B \leq 0.4\text{mm}$	$0.4 < B \leq 1.0\text{mm}$	$B > 1.0\text{mm}$	
		B-A	$B-A < 1/2B$	$B-A < 0.2$	$B-A < 0.25$	
		Judge	Acceptable	Acceptable	Acceptable	
		2. Dot Matrix				
		Deformation > 2°				Reject
Minor	Stain on LCD Panel Surface	Accept when stains can be wiped lightly with a soft cloth or a similar one. Otherwise, judged according to the above items: "Black spot" and "White Spot"				

8. RELIABILITY

NO.	Item	Condition	Criterion
1	High Temperature Operating	70°C , 96Hrs	No defect in cosmetic and operational function allowable. Total current Consumption should be below double of initial value.
2	Low Temperature Operating	-20°C , 96Hrs	
3	High Humidity	50°C , 90%RH, 96Hrs	
4	High Temperature Storage	80°C , 96Hrs	
5	Low Temperature Storage	-30°C , 96Hrs	
6	Vibration	Random wave 10 ~ 100Hz Acceleration: 2g 2 Hrs per direction(X,Y,Z)	
7	Thermal Shock	-20°C to 25°C to 70°C (60Min) (5Min) (60Min) 16Cycles	
8	ESD Testing	Contract Discharge Voltage: +1 ~ 5kV and -1 ~ -5kV Air Discharge Voltage: +1 ~ 8kV and -1 ~ -8kV	

Note: 1) Above conditions are suitable for our company standard products.

2) For restrict products, the test conditions listed as above must be revised.

9. HANDLING PRECAUTION

(1) Mounting Method

The panel of the LCD Module consists of two thin glass plates with polarizers which easily get damaged since the Module is fixed by utilizing fitting holes in the printed circuit board. Extreme care should be taken when handling the LCD Modules.

(2) Caution of LCD handling & cleaning

When cleaning the display surface, use soft cloth with solvent (recommended below) and wipe lightly.

- Isopropyl alcohol
- Ethyl alcohol
- Trichloro triflurothane

Do not wipe the display surface with dry or hard materials that will damage the polarizer surface.

Do not use the following solvent:

- Water
- Ketone
- Aromatics

(3) Caution against static charge

The LCD Module use C-MOS LSI drivers, so we recommend that you connect any unused input terminal to VDD or VSS, do not input any signals before power is turned on. And ground your body, Work/assembly table. And assembly equipment to protect against static electricity.

(4) Packaging

- Modules use LCD elements, and must be treated as such. Avoid intense shock and falls from a height.
- To prevent modules from degradation. Do not operate or store them exposed directly to sunshine or high temperature/humidity.

(5) Caution for operation

- It is indispensable to drive LCD's within the specified voltage limit since the higher voltage than the limit shorten LCD life. An electrochemical reaction due to direct current causes LCD deterioration, Avoid the use of direct current drive.
- Response time will be extremely delayed at lower temperature than the operating temperature range and on the other hand at higher temperature LCD's show dark color in them. However those phenomena do not mean malfunction or out of order with LCD's. Which will come back in the specified operating temperature range.
- If the display area is pushed hard during operation, some font will be abnormally displayed but it resumes normal condition after turning off once.
- A slight dew depositing on terminals is a cause for electro-chemical reaction resulting in terminal open circuit.

Usage under the relative condition of 40°C, 50%RH or less is required.

(6) Storage

In the case of storing for a long period of time (for instance.) For years) for the purpose or replacement use, The following ways are recommended.

- Storage in a polyethylene bag with sealed so as not to enter fresh air outside in it, And with no desiccant.
- Placing in a dark place where neither exposure to direct sunlight nor light is. Keeping temperature in the specified storage temperature range.
- Storing with no touch on polarizer surface by the anything else. (It is recommended to store them as they have been contained in the inner container at the time of delivery)

(7) Safety

- It is recommendable to crash damaged or unnecessary LCD into pieces and wash off liquid crystal by using solvents such as acetone and ethanol. Which should be burned up later.
- When any liquid crystal leaked out of a damaged glass cell comes in contact with your hands, please wash it off well with soap and water.

10. OUTLINE DIMENSION

