

PRODUCT SPECIFICATION

15.6" IPS TFT LCD MODULE

MODEL:T156192108-A0WMN-005 Ver:1.1



< ◇ > Preliminary Specification

< ◆ > Finally Specification

CUSTOMER'S APPROVAL	
CUSTOMER :	
SIGNATURE:	DATE:

APPROVED BY	PM REVIEWED	PD REVIEWED	PREPARED BY

Revision History

Revision	Date	Originator	Detail	Remarks
1.0	2018.01.18	ZFY	Initial Release	
1.1	2018.04.11	ZFY	Add many details	P21/P22

Table of Contents

No.	Item	Page
1.	General Description.....	4
2.	Module Parameter.....	4
3.	Absolute Maximum Ratings.....	4
4.	DC Characteristics	5
5.	Backlight Characteristic.....	5
5.1.	Backlight Characteristic.....	5
5.2.	Backlighting circuit.....	5
6.	Optical Characteristics	6
6.1.	Definition of Response Time	6
6.2.	Definition of Contrast Ratio	7
6.3.	Definition of Viewing Angles	7
6.4.	Definition of Color Appearance.....	8
6.5.	Definition of Surface Luminance, Uniformity and Transmittance	8
7.	Block Diagram and Power Supply.....	9
8.	Interface Pins Definition	10
9.	Timing Characteristics	12
10.	Input signal, basic display colors and gray scale of each color	13
11.	Quality Assurance	14
11.1.	Purpose	14
11.2.	Standard for Quality Test	14
11.3.	Nonconforming Analysis & Disposition.....	14
11.4.	Agreement Items	14
11.5.	Standard of the Product Visual Inspection	14
11.6.	Inspection Specification for the TFT module	15
11.7.	Classification of Defects	19
11.8.	Identification/marketing criteria.....	19
11.9.	Packaging.....	19
12.	Reliability Specification.....	20
13.	Precautions and Warranty.....	21
13.1.	Safety	21
13.2.	Handling	21
13.3.	Storage	21
13.4.	Metal Pin (Apply to Products with Metal Pins).....	21
13.5.	Operation.....	22
13.6.	Static Electricity	22
13.7.	Limited Warranty	22
14.	Packaging.....	23
15.	Outline Drawing.....	24

1. General Description

The specification is a transmissive type color active matrix liquid crystal display (LCD) which uses amorphous thin film transistor (TFT) as switching devices. This product is composed of a TFT-LCD panel, driver lcs, and a backlight unit.

2. Module Parameter

Features	Details	Unit
Display Size(Diagonal)	15.6"	
LCD type	IPS TFT	
Display Mode	Transmissive/Normally Black	
Resolution	1920 RGB x 1080	Pixels
View Direction	FULL VIEW	Best Image
Module Outline	360(H) x 212.3(V) x 6.4(T) (Note1)	mm
Active Area	344.16(H) x 193.59(V)	mm
Polarizer surface treatment	Anti-glare	
Pixel Size	179.25(H) x 179.25(V)	um
Display Colors	16.7 M	
Interface	eDP interface	
With or Without Touch Panel	Without	
Operating Temperature	-10~60	°C
Storage Temperature	-35~70	°C
Weight	TBD	g

Note 1: Exclusive hooks, posts, FFC/FPC tail etc.

3. Absolute Maximum Ratings

$V_{SS}=0V$, $T_a=25^{\circ}C$

Item	Symbol	Min.	Max.	Unit
Supply Voltage	LCD_VCC	-0.3	4.0	V
Storage temperature	T_{STG}	-35	+70	°C
Operating temperature	T_{OP}	-10	+60	°C

Note 1: If T_a below $50^{\circ}C$, the maximal humidity is 90%RH, if T_a over $50^{\circ}C$, absolute humidity should be less than 60%RH.

Note 2: The response time will be extremely slow when the operating temperature is around $-10^{\circ}C$, and the back ground will become darker at high temperature operating.

4. DC Characteristics

Item	Symbol	Min.	Typ.	Max.	Unit
Digital Interface Supply Voltage	LCD_VCC	3.0	3.3	3.6	V
Current Consumption Normally White	Logic	-	TBD	-	mA
	Analog				

5. Backlight Characteristic

5.1. Backlight Characteristic

Item	Symbol	Condition	Min.	Typ.	Max.	Unit
Forward Voltage	V_F	$T_a=25\text{ }^\circ\text{C}$, $I_F=20\text{mA/LED}$	28	31	33	V
Forward Current	I_F	$T_a=25\text{ }^\circ\text{C}$, $V_F=31\text{V}$	-	270	-	mA
Power dissipation	P_D		-	8370	-	mW
Uniformity	Avg	-	-	TBD	-	%
LED working life($25\text{ }^\circ\text{C}$)	-		-	10,000	-	Hrs
LED Configuration	36 White LEDs (9 LEDs in string and 4 groups in parallel)					

Note: LED life time defined as follows: The final brightness is at 50% of original brightness.

The environmental conducted under ambient air flow, at $T_a=25\pm 2\text{ }^\circ\text{C}$, $60\%\text{RH}\pm 5\%$, $I_F=270\text{mA}$.

5.2. Backlighting circuit

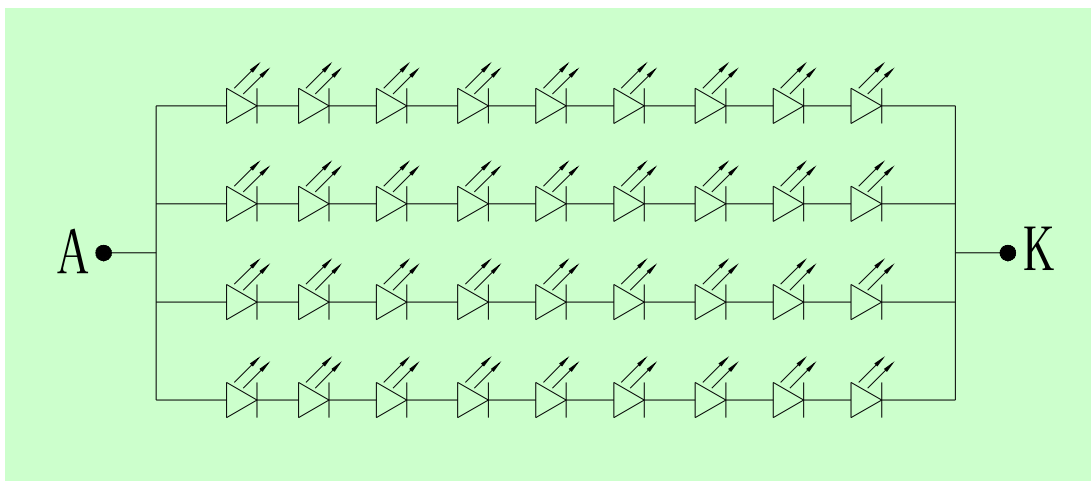

6. Optical Characteristics

Ta=25°C, LCD_VCC=3.3V

	Item	Symbol	Condition	Specification			Unit	
				Min.	Typ.	Max.		
Backlight On (Transmissive Mode)	Luminance on TFT($I_f=270\text{mA}$)	Lv		400	500	-	cd/m ²	
	Contrast ratio(See 6.3)	CR		700	1000	-		
	Response time (See 6.2)	TR+TF		-	25	35	ms	
	Chromaticity Transmissive (See 6.5)	Red	X _R	Center CR≥10	-	TBD	-	
			Y _R		-	TBD	-	
		Green	X _G		-	TBD	-	
			Y _G		-	TBD	-	
		Blue	X _B		-	TBD	-	
			Y _B		-	TBD	-	
	White	X _W	-	TBD	-			
Y _W		-	TBD	-				
Viewing Angle (See 6.4)	Horizontal	θ _{X+}	Center CR≥10	-	(89)	-	Deg.	
		θ _{X-}		-	(89)	-		
	Vertical	φ _{Y+}		-	(89)	-		
		φ _{Y-}		-	(89)	-		
NTSC ratio (Color gamut)				-	45	-	%	

6.1. Definition of Response Time

6.1.1. Normally Black Type (Negative)

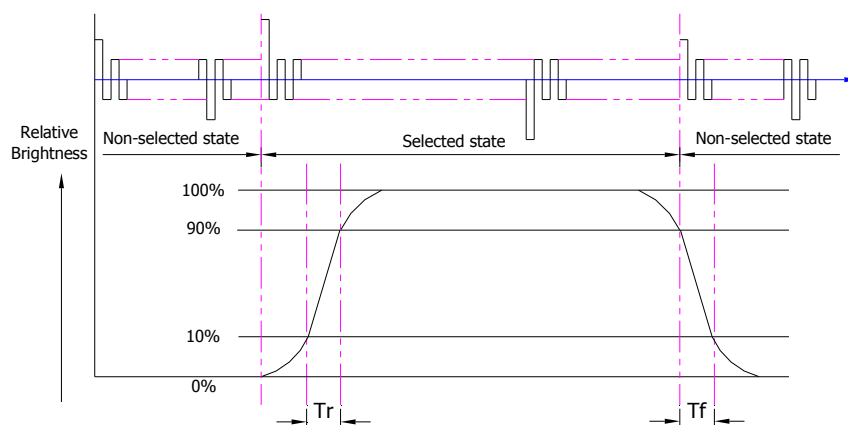

T_r is the time it takes to change from non-selected stage with relative luminance 10% to selected state with relative luminance 90%;

T_f is the time it takes to change from selected state with relative luminance 90% to non-selected state with relative luminance 10%.

Note: Measuring machine: LCD-5100

6.1.2. Normally White Type (Positive)

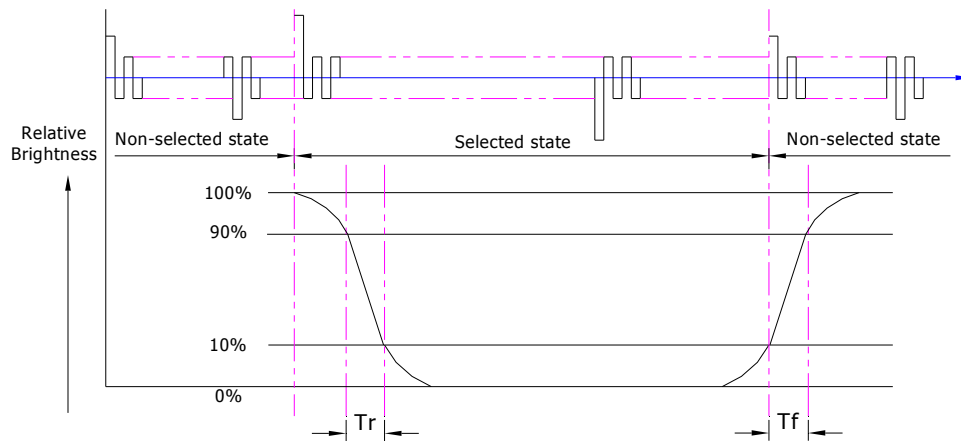

Tr is the time it takes to change from non-selected state with relative luminance 90% to selected state with relative luminance 10%;

Tf is the time it takes to change from selected state with relative luminance 10% to non-selected state with relative luminance 90%;

Note: Measuring machine: LCD-5100 or EQUI

6.2. Definition of Contrast Ratio

Contrast is measured perpendicular to display surface in reflective and transmissive mode.

The measurement condition is:

Measuring Equipment	Eldim or Equivalent
Measuring Point Diameter	3mm//1mm
Measuring Point Location	Active Area centre point
Test pattern	A: All Pixels white
	B: All Pixel black
Contrast setting	Maximum

Definitions: CR (Contrast) = Luminance of White Pixel / Luminance of Black Pixel

6.3. Definition of Viewing Angles

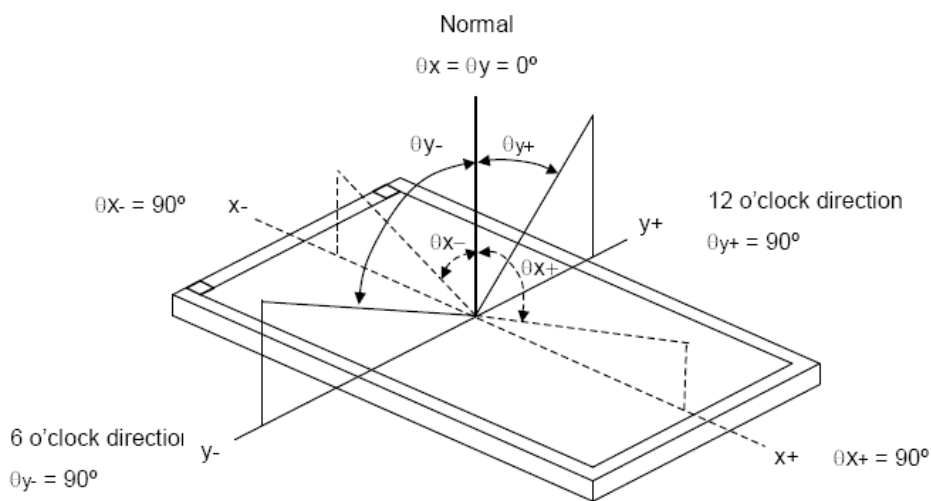

Measuring machine: LCD-5100 or EQUI

6.4. Definition of Color Appearance

R,G,B and W are defined by (x, y) on the IE chromaticity diagram

NTSC=area of RGB triangle/area of NTSC triangleX100%

Measuring picture: Red, Green, Blue and White (Measuring machine: BM-7)

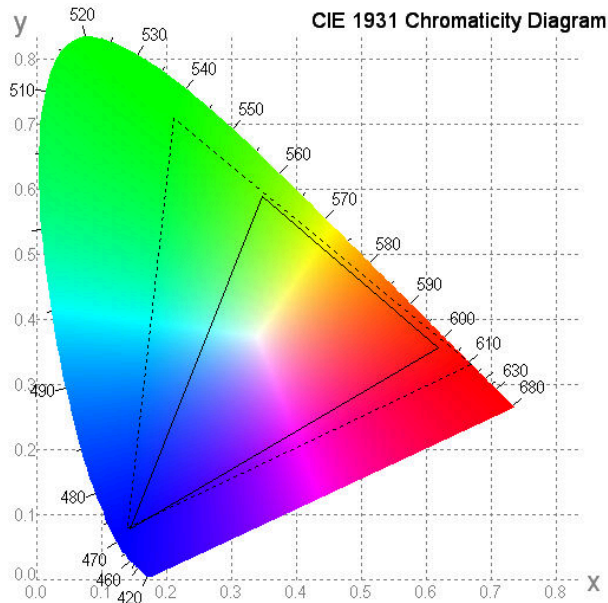

6.5. Definition of Surface Luminance, Uniformity and Transmittance

Using the transmissive mode measurement approach, measure the white screen luminance of the display panel and backlight.

6.5.1. Surface Luminance: $L_V = \text{average} (L_{P1}:L_{P9})$

6.5.2. Uniformity = Minimal ($L_{P1}:L_{P9}$) / Maximal ($L_{P1}:L_{P9}$) * 100%

6.5.3. Transmittance = L_V on LCD / L_V on Backlight * 100%

Note: Measuring machine: BM-7

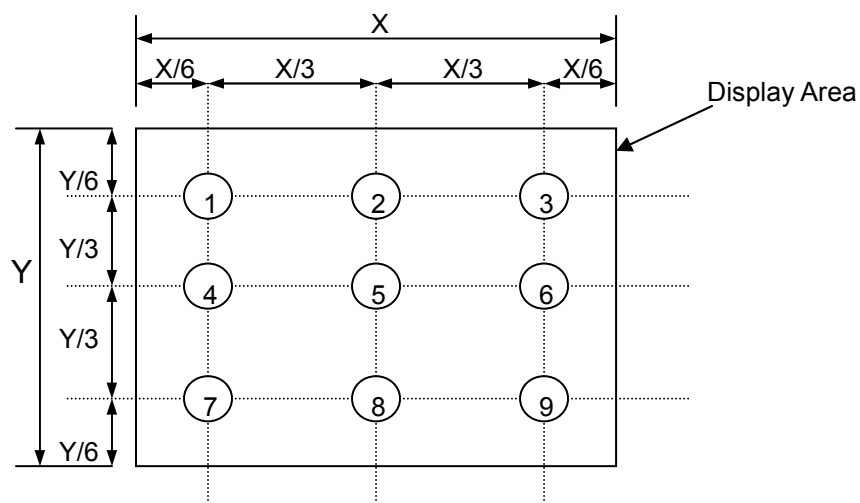

7. Block Diagram and Power Supply

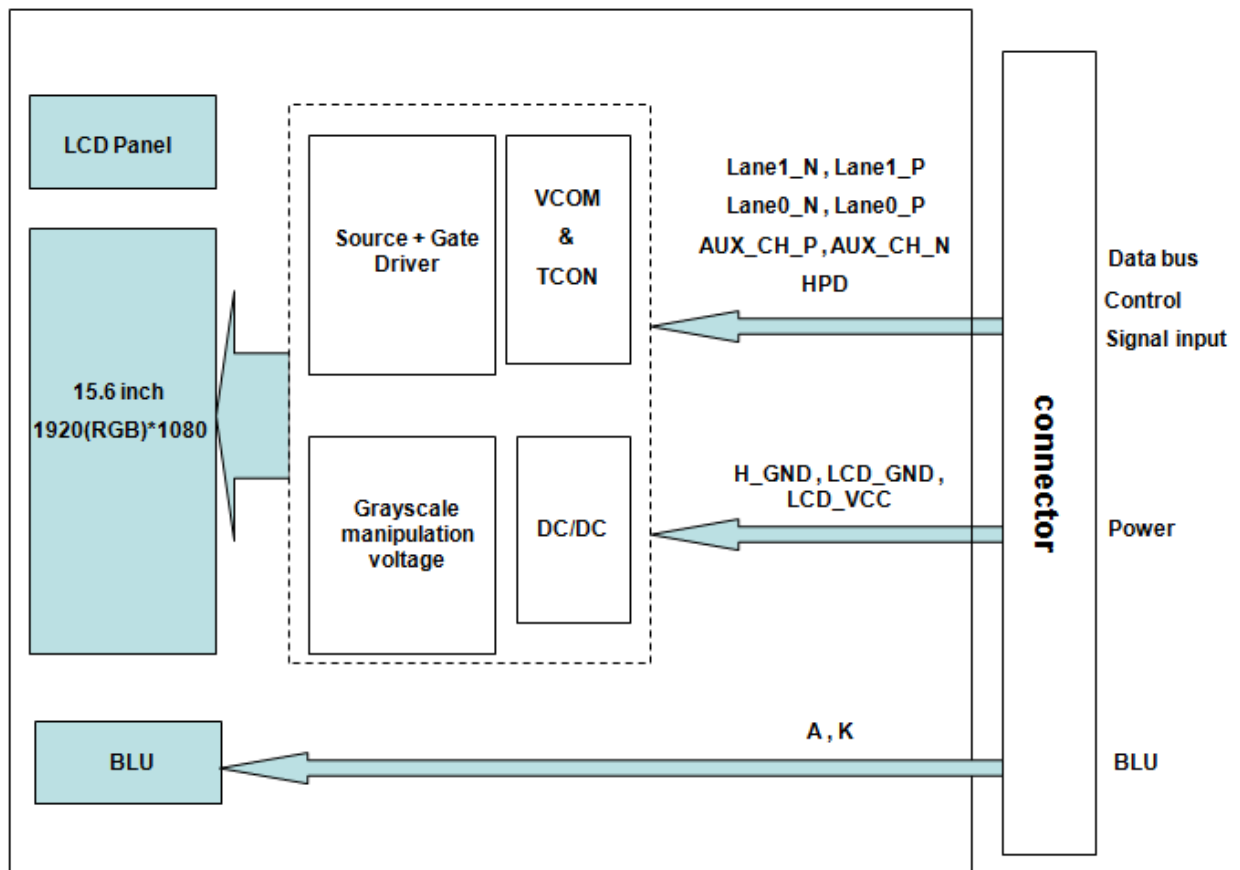

8. Interface Pins Definition

No.	Symbol	Function	Remark
1	NC	Reserved for LCD	[Note4-1-1]
2	H_GND	High Speed Ground.	[Note4-1-2]
3	Lane1_N	Complement Signal Link Lane 1	
4	Lane1_P	True Signal Link Lane 1	
5	H_GND	High Speed Ground.	[Note4-1-2]
6	Lane0_N	Complement Signal Link Lane 0	
7	Lane0_P	True Signal Link Lane 0	
8	H_GND	Reserved for LCD	[Note4-1-2]
9	AUX_CH_P	True Signal Auxiliary Channel	
10	AUX_CH_N	Complement Signal Auxiliary Channel	
11	H_GND	High Speed Ground.	[Note4-1-2]
12	LCD_VCC	LCD logic and driver power(3.3V)	
13	LCD_VCC	LCD logic and driver power(3.3V)	
14	NC	Reserved For LCD manufacture's use	[Note4-1-1]
15	LCD_GND	LCD logic and driver ground	
16	LCD_GND	LCD logic and driver ground	
17	HPD	HPD Signal	[Note4-1-3]
18 ~ 30	NC	No connection	

[Note 4-1-1] Don't input any signals or any powers into a NC pin. Keep the NC pin open.

[Note 4-1-2] The shielding case is connected with signal GND.

- Connector used :20455-030E-66 (I-PEX)
- Corresponding connector : 20453-030T (I-PEX)

The equivalent circuit figure of the terminal.

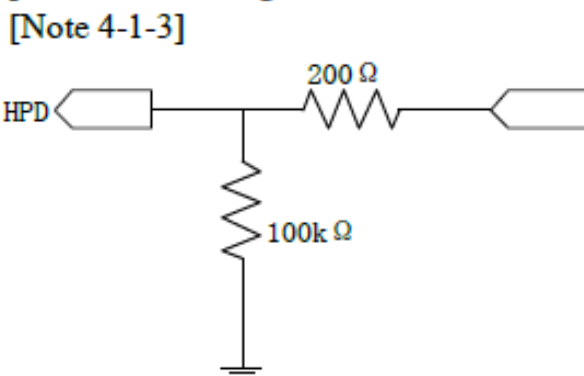

Fig.4-1-1 Equivalent circuit (Pin No.17)

eDP interface

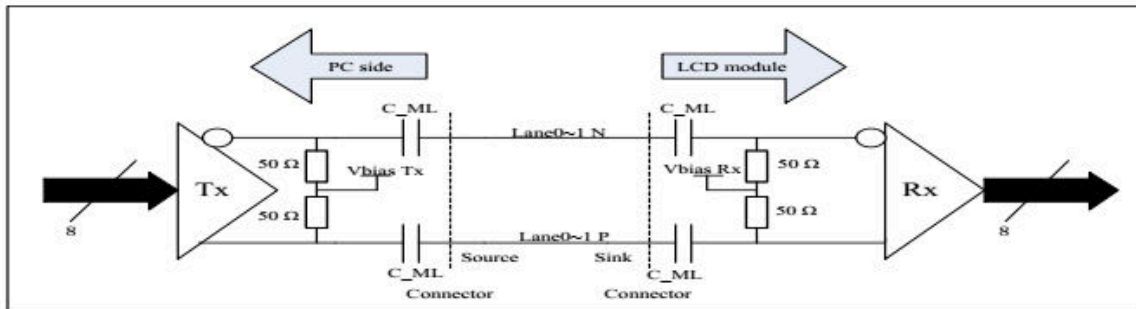
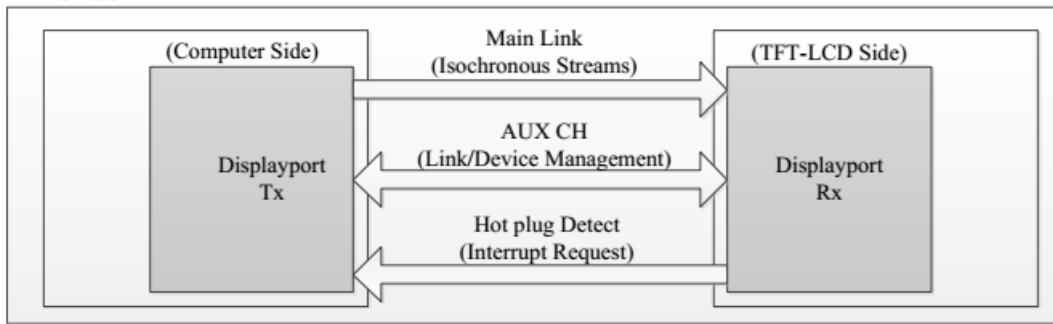

Fig.4-3-2 Main Link differential pair

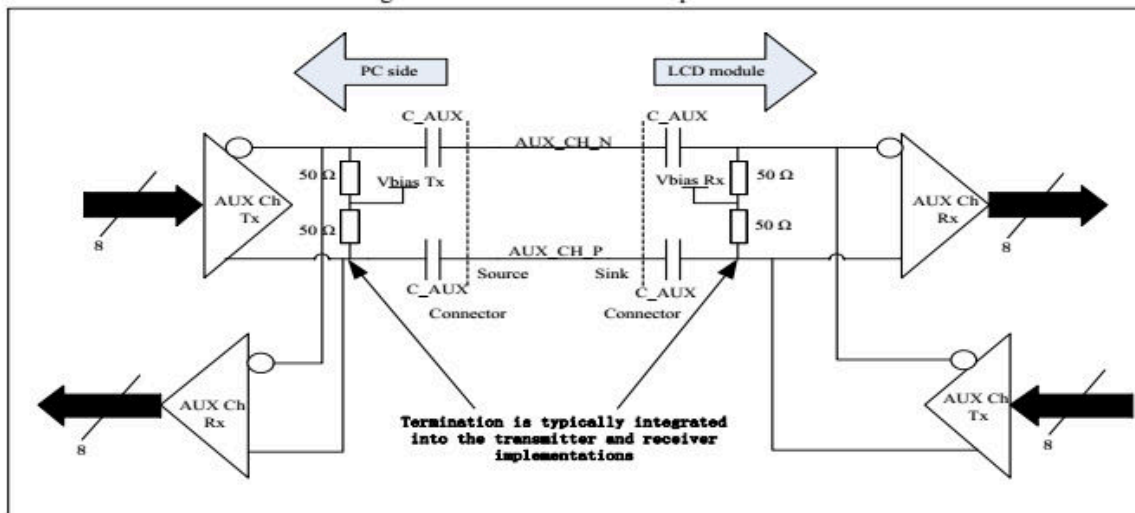

Fig.4-3-3 AUX Link differential pair

Lane0	Lane1
R0-5:0	R1-5:0
G0-5:0	G1-5:0
B0-5:0	B1-5:0
R2-5:0	R3-5:0
G2-5:0	G3-5:0
B2-5:0	B3-5:0
R4-5:0	R5-5:0
G4-5:0	G5-5:0
B4-5:0	B5-5:0

9. Timing Characteristics

1) Timing Characteristic

Parameter	Symbol	Min.	Typ.	Max.	Unit	Remark		
Clock	Frequency	1/T _C	132.0	138.5	140.0	MHz	[Note 6-1-1]	
Data enable signal	Horizontal period	TH	2020	2080	2400	clock		
	Horizontal period (High)	THd	-	15.02	-	μs		
	Vertical period	TV	1090	1111	1200	line		
				-	16.685	-	ms	
		Vertical period (High)	TVd	-	1080	-	line	

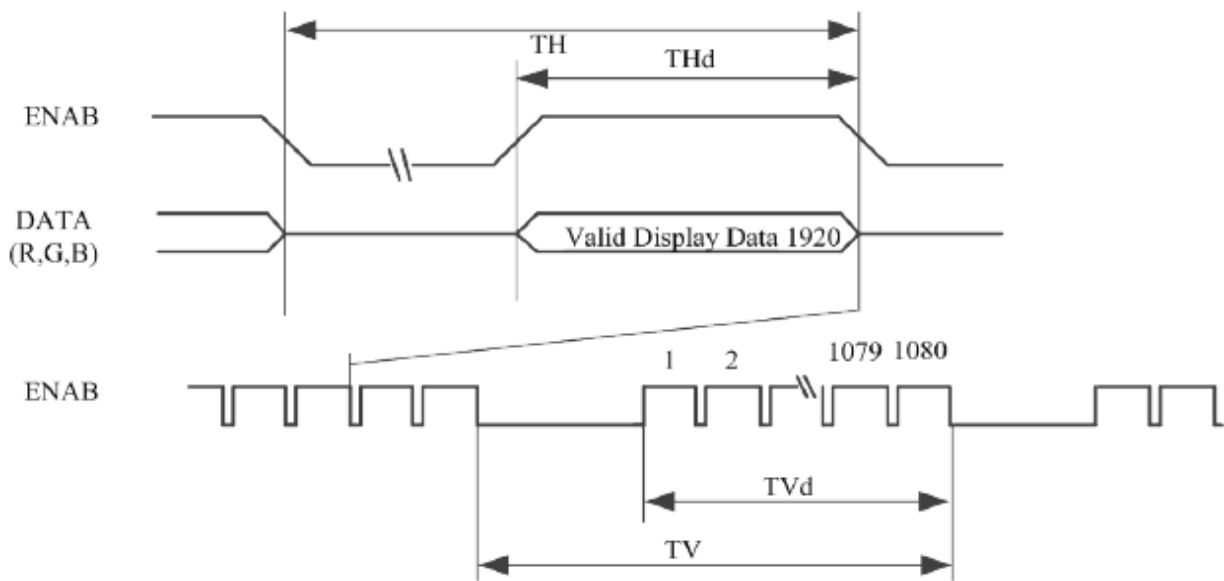

2) Data Input data signal and display position on the screen

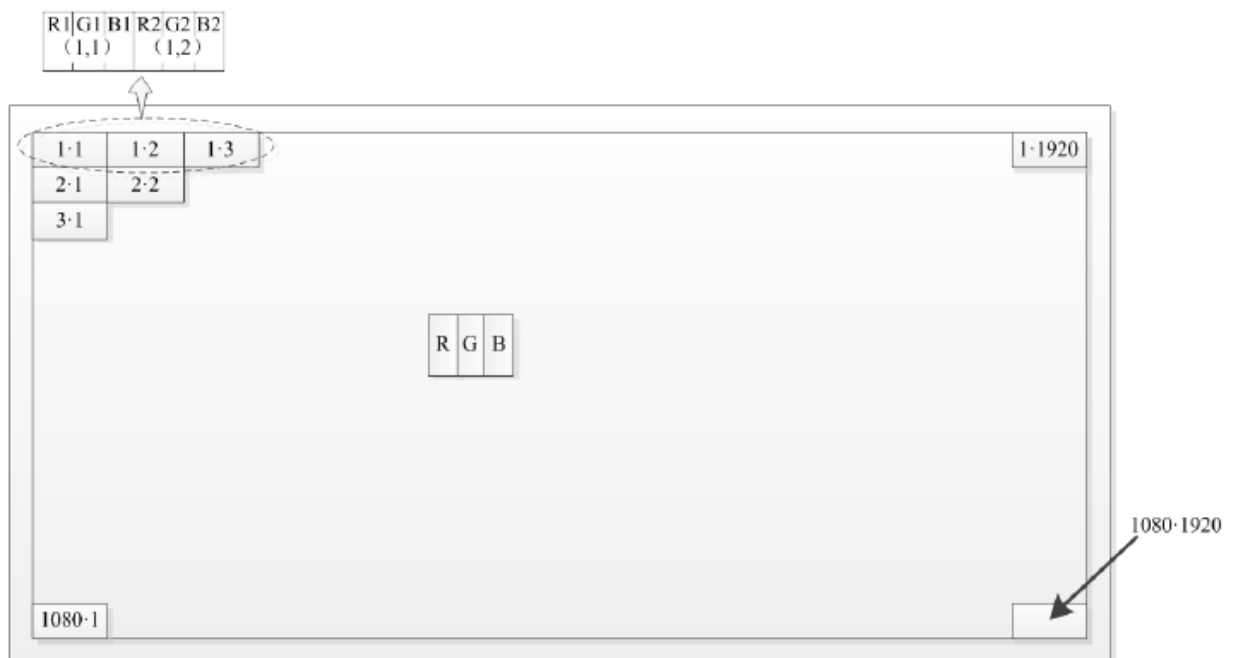

10. Input signal, basic display colors and gray scale of each color

Colors & Gray Scale	Gray Scale	Data signal																		
		R0	R1	R2	R3	R4	R5	G0	G1	G2	G3	G4	G5	B0	B1	B2	B3	B4	B5	
		LSB					MSB					LSB					MSB			
Basic Color	Black	-	0	0	0	0	0	0	0	0	0	0	0	0	0	0	0	0	0	0
	Blue	-	0	0	0	0	0	0	0	0	0	0	0	0	1	1	1	1	1	1
	Green	-	0	0	0	0	0	0	1	1	1	1	1	1	0	0	0	0	0	0
	Cyan	-	0	0	0	0	0	0	1	1	1	1	1	1	1	1	1	1	1	1
	Red	-	1	1	1	1	1	1	0	0	0	0	0	0	0	0	0	0	0	0
	Magenta	-	1	1	1	1	1	1	0	0	0	0	0	0	1	1	1	1	1	1
	Yellow	-	1	1	1	1	1	1	1	1	1	1	1	1	0	0	0	0	0	0
	White	-	1	1	1	1	1	1	1	1	1	1	1	1	1	1	1	1	1	1
Gray Scale of Red	Black	GS0	0	0	0	0	0	0	0	0	0	0	0	0	0	0	0	0	0	0
	↑	GS1	1	0	0	0	0	0	0	0	0	0	0	0	0	0	0	0	0	0
	Darker	GS2	0	1	0	0	0	0	0	0	0	0	0	0	0	0	0	0	0	0
	↑	↓	↓					↓					↓							
	↓	↓	↓					↓					↓							
	Brighter	GS25	1	0	1	1	1	1	0	0	0	0	0	0	0	0	0	0	0	0
	↓	GS25	0	1	1	1	1	1	0	0	0	0	0	0	0	0	0	0	0	0
	Red	GS25	1	1	1	1	1	1	0	0	0	0	0	0	0	0	0	0	0	0
Gray Scale of Green	Black	GS0	0	0	0	0	0	0	0	0	0	0	0	0	0	0	0	0	0	0
	↑	GS1	0	0	0	0	0	0	1	0	0	0	0	0	0	0	0	0	0	0
	Darker	GS2	0	0	0	0	0	0	0	1	0	0	0	0	0	0	0	0	0	0
	↑	↓	↓					↓					↓							
	↓	↓	↓					↓					↓							
	Brighter	GS25	0	0	0	0	0	0	1	0	1	1	1	1	0	0	0	0	0	0
	↓	GS25	0	0	0	0	0	0	0	1	1	1	1	1	0	0	0	0	0	0
	Green	GS25	0	0	0	0	0	0	1	1	1	1	1	1	0	0	0	0	0	0
Gray Scale of Blue	Black	GS0	0	0	0	0	0	0	0	0	0	0	0	0	0	0	0	0	0	0
	↑	GS1	0	0	0	0	0	0	0	0	0	0	0	1	0	0	0	0	0	0
	Darker	GS2	0	0	0	0	0	0	0	0	0	0	0	0	1	0	0	0	0	0
	↑	↓	↓					↓					↓							
	↓	↓	↓					↓					↓							
	Brighter	GS25	0	0	0	0	0	0	0	0	0	0	0	0	1	0	1	1	1	1
	↓	GS25	0	0	0	0	0	0	0	0	0	0	0	0	0	1	1	1	1	1
	Blue	GS25	0	0	0	0	0	0	0	0	0	0	0	0	1	1	1	1	1	1

0: Low level voltage, 1: High level voltage.

Each basic color can be displayed in 64 gray scales from 6 bit data signals.

According to the combination of 18 bit data signals, the 262144color display can be achieved on the screen

11. Quality Assurance

11.1.Purpose

This standard for Quality Assurance assures the quality of LCD module products supplied to customer.

11.2.Standard for Quality Test

11.2.1 Sampling Plan:

GB2828.1-2012

Single sampling, general inspection level II.

11.2.2 Sampling Criteria:

Visual inspection: AQL 1.5%

Electrical functional: AQL 0.65%.

11.2.3 Reliability Test:

Detailed requirement refer to Reliability Test Specification.

11.3.Nonconforming Analysis & Disposition

11.3.1 Nonconforming analysis:

11.3.1.1 Customer should provide overall information of non-conforming sample for their complaints.

11.3.1.2 After receipt of detailed information from customer, the analysis of nonconforming parts usually should be finished in one week.

11.3.1.3 If cannot finish the analysis on time, customer will be notified with the progress status.

11.3.2 Disposition of nonconforming:

11.3.2.1 Non-conforming product over PPM level will be replaced.

11.3.2.2 The cause of non-conformance will be analyzed. Corrective action will be discussed and implemented.

11.4.Agreement Items

Shall negotiate with customer if the following situation occurs:

11.4.1 There is any discrepancy in standard of quality assurance.

11.4.2 Additional requirement to be added in product specification.

11.4.3 Any other special problem.

11.5.Standard of the Product Visual Inspection

11.5.1 Appearance inspection:

11.5.1.1 The inspection must be under illumination about 1000 – 1500 lx, and the distance of view must be at 30cm ± 2cm.

11.5.1.2 The viewing angle should be 45° from the vertical line without reflection light or follows customer's viewing angle specifications.

11.5.1.3 Definition of area: A Zone: Active Area, B Zone: Viewing Area,

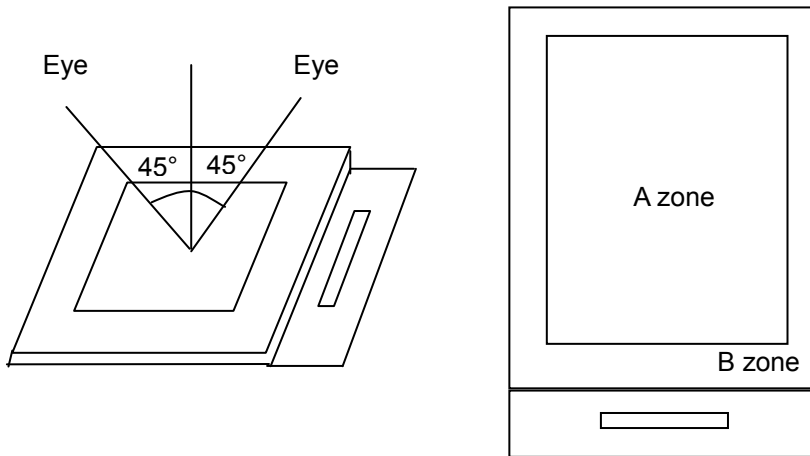

11.5.2 Basic principle:

11.5.2.1 A set of sample to indicate the limit of acceptable quality level must be discussed by both us and customer when there is any dispute happened.

11.5.2.2 New item must be added on time when it is necessary.

11.6. Inspection Specification for the TFT module

No.	Item	Criteria (Unit: mm)																		
01	Black / White spot Foreign material (Round type) Pinholes Stain Particles inside cell. (Minor defect)	<p>$\phi = (a + b) / 2$ Distance between 2 defects should more than 5mm apart.</p> <table border="1"> <thead> <tr> <th>Size</th> <th>Area</th> <th>Acc. Qty</th> </tr> </thead> <tbody> <tr> <td>$\phi \leq 0.20$</td> <td></td> <td>Ignore</td> </tr> <tr> <td>$0.20 < \phi \leq 0.50$</td> <td></td> <td>$N \leq 3$</td> </tr> <tr> <td>$0.50 < \phi$</td> <td></td> <td>0</td> </tr> </tbody> </table>	Size	Area	Acc. Qty	$\phi \leq 0.20$		Ignore	$0.20 < \phi \leq 0.50$		$N \leq 3$	$0.50 < \phi$		0						
Size	Area	Acc. Qty																		
$\phi \leq 0.20$		Ignore																		
$0.20 < \phi \leq 0.50$		$N \leq 3$																		
$0.50 < \phi$		0																		
02	Electrical Defect (Minor defect)	<table border="1"> <thead> <tr> <th>Bright dot</th> <th>Display Area</th> <th>Total</th> <th rowspan="3">Note1</th> </tr> </thead> <tbody> <tr> <td></td> <td>$N \leq 2$</td> <td>$N \leq 2$</td> </tr> <tr> <td>Dark dot</td> <td>$N \leq 4$</td> <td>$N \leq 4$</td> </tr> <tr> <td>Total dot</td> <td>$N \leq 4$</td> <td>$N \leq 4$</td> <td></td> </tr> <tr> <td>Mura</td> <td colspan="2">Not visible through 5% ND filter.</td> <td>Note 2</td> </tr> </tbody> </table> <p>Remark: 1. Bright dot caused by scratch and foreign object accords to item 1.</p>	Bright dot	Display Area	Total	Note1		$N \leq 2$	$N \leq 2$	Dark dot	$N \leq 4$	$N \leq 4$	Total dot	$N \leq 4$	$N \leq 4$		Mura	Not visible through 5% ND filter.		Note 2
Bright dot	Display Area	Total	Note1																	
	$N \leq 2$	$N \leq 2$																		
Dark dot	$N \leq 4$	$N \leq 4$																		
Total dot	$N \leq 4$	$N \leq 4$																		
Mura	Not visible through 5% ND filter.		Note 2																	

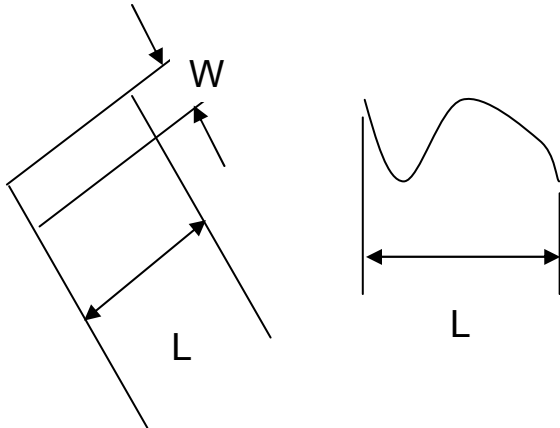
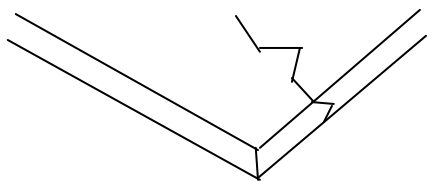
<p>03</p>	<p>Black and White line Scratch Foreign material (Line type) (Minor defect)</p>	 <table border="1" data-bbox="574 705 1204 974"> <thead> <tr> <th>Length</th> <th>Width</th> <th>Acc. Qty</th> </tr> </thead> <tbody> <tr> <td>/</td> <td>$W \leq 0.1$</td> <td>Ignore</td> </tr> <tr> <td>$L \leq 2.5$</td> <td>$0.1 < W \leq 0.2$</td> <td>3</td> </tr> <tr> <td>$L > 2.5$</td> <td>$0.2 < W$</td> <td>0</td> </tr> <tr> <td colspan="2">Total</td> <td>3</td> </tr> </tbody> </table> <p>Distance between 2 defects should more than 3mm apart. Scratches not viewable through the back of the display are acceptable.</p>	Length	Width	Acc. Qty	/	$W \leq 0.1$	Ignore	$L \leq 2.5$	$0.1 < W \leq 0.2$	3	$L > 2.5$	$0.2 < W$	0	Total		3
Length	Width	Acc. Qty															
/	$W \leq 0.1$	Ignore															
$L \leq 2.5$	$0.1 < W \leq 0.2$	3															
$L > 2.5$	$0.2 < W$	0															
Total		3															
<p>04</p>	<p>Glass Crack (Minor defect)</p>	 <p>Crack is potential to enlarge, any type is not allowed.</p>															

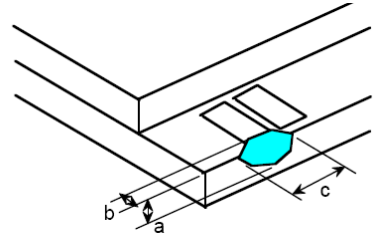
<p>05</p>	<p>Glass Chipping Pad Area: (Minor defect)</p> 	<table border="1" data-bbox="901 1657 1372 1836"> <thead> <tr> <th>Length and Width</th> <th>Acc. Qty</th> </tr> </thead> <tbody> <tr> <td>$c > 3.0, b < 1.0$</td> <td>1</td> </tr> <tr> <td>$c < 3.0, b < 1.0$</td> <td>3</td> </tr> <tr> <td colspan="2">$a < \text{Glass Thickness}$</td> </tr> </tbody> </table>	Length and Width	Acc. Qty	$c > 3.0, b < 1.0$	1	$c < 3.0, b < 1.0$	3	$a < \text{Glass Thickness}$	
Length and Width	Acc. Qty									
$c > 3.0, b < 1.0$	1									
$c < 3.0, b < 1.0$	3									
$a < \text{Glass Thickness}$										

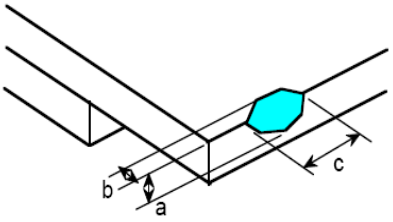
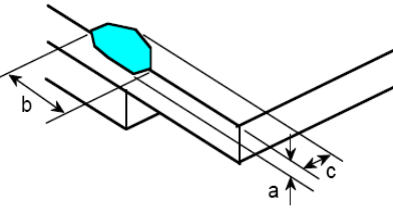
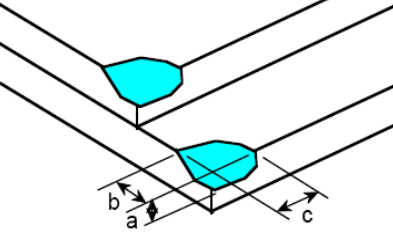
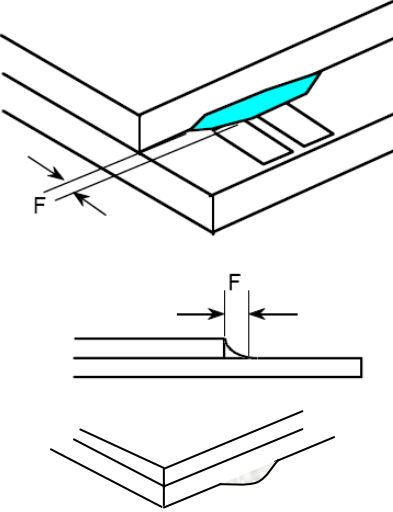
<p>06</p>	<p>Glass Chipping Rear of Pad Area: (Minor defect)</p> 	<table border="1"> <thead> <tr> <th>Length and Width</th> <th>Acc. Qty</th> </tr> </thead> <tbody> <tr> <td>$c > 3.0, b < 1.0$</td> <td>1</td> </tr> <tr> <td>$c < 3.0, b < 1.0$</td> <td>2</td> </tr> <tr> <td>$c < 3.0, b < 0.5$</td> <td>4</td> </tr> <tr> <td colspan="2" style="text-align: center;">$a < \text{Glass Thickness}$</td> </tr> </tbody> </table>	Length and Width	Acc. Qty	$c > 3.0, b < 1.0$	1	$c < 3.0, b < 1.0$	2	$c < 3.0, b < 0.5$	4	$a < \text{Glass Thickness}$	
Length and Width	Acc. Qty											
$c > 3.0, b < 1.0$	1											
$c < 3.0, b < 1.0$	2											
$c < 3.0, b < 0.5$	4											
$a < \text{Glass Thickness}$												
<p>07</p>	<p>Glass Chipping Except Pad Area: (Minor defect)</p> 	<table border="1"> <thead> <tr> <th>Length and Width</th> <th>Acc. Qty</th> </tr> </thead> <tbody> <tr> <td>$c > 3.0, b < 1.0$</td> <td>1</td> </tr> <tr> <td>$c < 3.0, b < 1.0$</td> <td>2</td> </tr> <tr> <td>$c < 3.0, b < 0.5$</td> <td>4</td> </tr> <tr> <td colspan="2" style="text-align: center;">$a < \text{Glass Thickness}$</td> </tr> </tbody> </table>	Length and Width	Acc. Qty	$c > 3.0, b < 1.0$	1	$c < 3.0, b < 1.0$	2	$c < 3.0, b < 0.5$	4	$a < \text{Glass Thickness}$	
Length and Width	Acc. Qty											
$c > 3.0, b < 1.0$	1											
$c < 3.0, b < 1.0$	2											
$c < 3.0, b < 0.5$	4											
$a < \text{Glass Thickness}$												
<p>08</p>	<p>Glass Corner Chipping: (Minor defect)</p> 	<table border="1"> <thead> <tr> <th>Length and Width</th> <th>Acc. Qty</th> </tr> </thead> <tbody> <tr> <td>$c < 3.0, b < 3.0$</td> <td>Ignore</td> </tr> <tr> <td colspan="2" style="text-align: center;">$a < \text{Glass Thickness}$</td> </tr> </tbody> </table>	Length and Width	Acc. Qty	$c < 3.0, b < 3.0$	Ignore	$a < \text{Glass Thickness}$					
Length and Width	Acc. Qty											
$c < 3.0, b < 3.0$	Ignore											
$a < \text{Glass Thickness}$												
<p>9</p>	<p>Glass Burr: (Minor defect)</p> 	<table border="1"> <thead> <tr> <th>Length</th> <th>Acc. Qty</th> </tr> </thead> <tbody> <tr> <td>$F < 1.0$</td> <td>Ignore</td> </tr> </tbody> </table> <p>Glass burr don't affect assemble and module dimension.</p>	Length	Acc. Qty	$F < 1.0$	Ignore						
Length	Acc. Qty											
$F < 1.0$	Ignore											

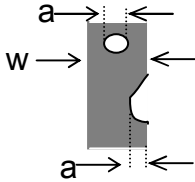
10	<p>FPC Defect: (Minor defect)</p> 	<p>10.1 Dent, pinhole width $a < w/3$. (w: circuitry width.) 10.2 Open circuit is unacceptable. 10.3 No oxidation, contamination and distortion.</p>								
11	<p>Bubble on Polarizer (Minor defect)</p>	<table border="1" data-bbox="775 618 1246 790"> <thead> <tr> <th>Diameter</th> <th>Acc. Qty</th> </tr> </thead> <tbody> <tr> <td>$\phi \leq 0.30$</td> <td>Ignore</td> </tr> <tr> <td>$0.30 < \phi \leq 0.50$</td> <td>$N \leq 2$</td> </tr> <tr> <td>$0.50 < \phi$</td> <td>$N = 0$</td> </tr> </tbody> </table>	Diameter	Acc. Qty	$\phi \leq 0.30$	Ignore	$0.30 < \phi \leq 0.50$	$N \leq 2$	$0.50 < \phi$	$N = 0$
Diameter	Acc. Qty									
$\phi \leq 0.30$	Ignore									
$0.30 < \phi \leq 0.50$	$N \leq 2$									
$0.50 < \phi$	$N = 0$									
12	<p>Dent on Polarizer (Minor defect)</p>	<table border="1" data-bbox="775 857 1246 1030"> <thead> <tr> <th>Diameter</th> <th>Acc. Qty</th> </tr> </thead> <tbody> <tr> <td>$\phi \leq 0.25$</td> <td>Ignore</td> </tr> <tr> <td>$0.25 < \phi \leq 0.50$</td> <td>$N \leq 4$</td> </tr> <tr> <td>$0.50 < \phi$</td> <td>None</td> </tr> </tbody> </table>	Diameter	Acc. Qty	$\phi \leq 0.25$	Ignore	$0.25 < \phi \leq 0.50$	$N \leq 4$	$0.50 < \phi$	None
Diameter	Acc. Qty									
$\phi \leq 0.25$	Ignore									
$0.25 < \phi \leq 0.50$	$N \leq 4$									
$0.50 < \phi$	None									
13	<p>Bezel</p>	<p>13.1 No rust, distortion on the Bezel. 13.2 No visible fingerprints, stains or other contamination.</p>								
14	<p>Touch Panel</p>	<p>D: Diameter W: width L: length 14.1 Spot: $D < 0.25$ is acceptable $0.25 \leq D \leq 0.4$ 2dots are acceptable and the distance between defects should more than 10 mm. $D > 0.4$ is unacceptable 14.2 Dent: $D > 0.40$ is unacceptable 14.3 Scratch: $W \leq 0.03$, $L \leq 10$ is acceptable, $0.03 < W \leq 0.10$, $L \leq 10$ is acceptable Distance between 2 defects should more than 10 mm. $W > 0.10$ is unacceptable.</p>								
15	<p>PCB</p>	<p>15.1 No distortion or contamination on PCB terminals. 15.2 All components on PCB must same as documented on the BOM/component layout. 15.3 Follow IPC-A-600F.</p>								
16	<p>Soldering</p>	<p>Follow IPC-A-610C standard</p>								

17	Electrical Defect (Major defect)	<p>The below defects must be rejected.</p> <p>17.1 Missing vertical / horizontal segment, 17.2 Abnormal Display. 17.3 No function or no display. 17.4 Current exceeds product specifications. 17.5 LCD viewing angle defect. 17.6 No Backlight. 17.7 Dark Backlight. 17.8 Touch Panel no function.</p>
----	-------------------------------------	--

Remark: LCD Panel Broken shall be rejected. Defect out of LCD viewing area is acceptable.

11.7. Classification of Defects

11.8.1 Visual defects (Except no / wrong label) are treated as minor defect and electrical defect is major.

11.8.2 Two minor defects are equal to one major in lot sampling inspection.

11.8. Identification/marketing criteria

Any unit with illegible / wrong /double or no marking/ label shall be rejected.

11.9. Packaging

11.10.1 There should be no damage of the outside carton box, each packaging box should have one identical label.

11.10.2 Modules inside package box should have compliant mark.

11.10.3 All direct package materials shall offer ESD protection

Note1: Bright dot is defined as the defective area of the dot is larger than 50% of one sub-pixel area.

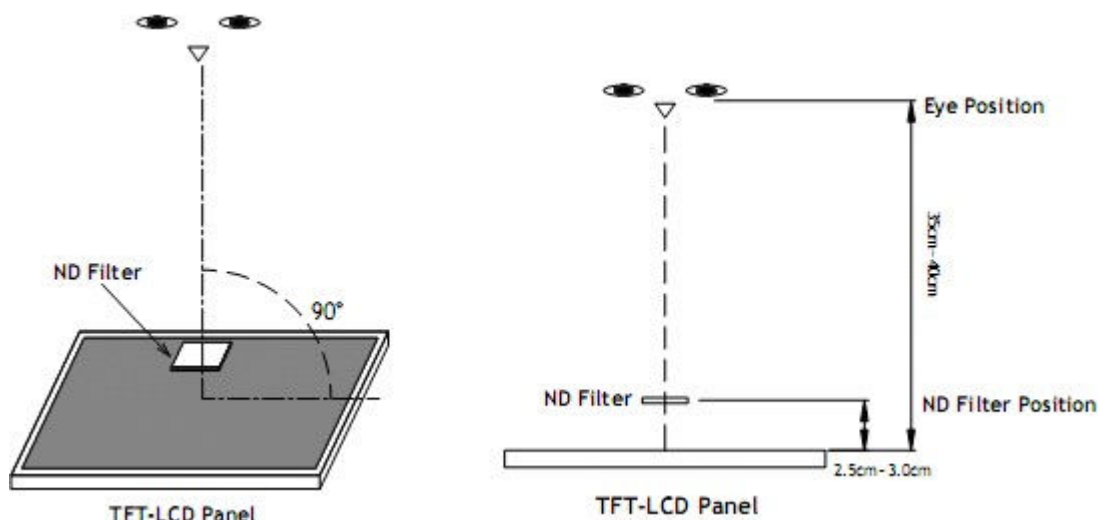

Bright dot: The bright dot size defect at black display pattern. It can be recognized by 2% transparency of filter when the distance between eyes and panel is $350\text{mm} \pm 50\text{mm}$.

Dark dot: Cyan, Magenta or Yellow dot size defect at white display pattern. It can be recognized by 5% transparency of filter when the distance between eyes and panel is $350\text{mm} \pm 50\text{mm}$.

Note2: Mura on display which appears darker / brighter against background brightness on parts of display area.

12. Reliability Specification

No	Item	Condition	Quantity	Criteria
1	High Temperature Operating	60°C, 240Hrs	2	GB/T2423.2-2008
2	Low Temperature Operating	-10°C, 240Hrs	2	GB/T2423.1-2008
3	High Humidity	40°C, 90%RH, 240Hrs	2	GB/T2423.3-2006
4	High Temperature Storage	70°C, 240Hrs	2	GB/T2423.2-2008
5	Low Temperature Storage	-35°C, 240Hrs	2	GB/T2423.1-2008
6	Thermal Cycling Test	-10°C, 60min~60°C, 60min, 20 cycles.	2	GB/T2423.22-2012
7	Packing vibration	Frequency range:10Hz~50Hz Acceleration of gravity:5G X, Y, Z 30 min for each direction.	2	GB/T5170.14-2009
8	Electrical Static Discharge	Air: ±4KV 150pF/330 Ω 5 times	2	GB/T17626.2-2006
		Contact: ±2KV 150pF/330 Ω 5 times		
9	Drop Test (Packaged)	Height:80 cm,1 corner, 3 edges, 6 surfaces.	2	GB/T2423.8-1995

Note1. No deflection cosmetic and operational function allowable.

Note2. Total current Consumption should be below double of initial value

13. Precautions and Warranty

13.1.Safety

13.1.1 The liquid crystal in the LCD is poisonous. Do not put it in your mouth. If the liquid crystal touches your skin or clothes, wash it off immediately using soap and water.

13.1.2 Since the liquid crystal cells are made of glass, do not apply strong impact on them. Handle with care.

13.2.Handling

13.2.1 Reverse and use within ratings in order to keep performance and prevent damage.

13.2.2 Do not wipe the polarizer with dry cloth, as it might cause scratch. If the surface of the LCD needs to be cleaned, wipe it swiftly with cotton or other soft cloth soaked with petroleum IPA, do not use other chemicals.

13.3.Storage

13.3.1. Do not store the LCD module beyond the specified temperature ranges.

13.3.2. Strong light exposure causes degradation of polarizer and color filter

13.4.Metal Pin (Apply to Products with Metal Pins)

13.4.1 Pins of LCD and Backlight

13.4.1.1 Solder tip can touch and press on the tip of Pin LEAD during the soldering

13.4.1.2 Recommended Soldering Conditions

Solder Type: Sn96.3~94-Ag3.3~4.3-Cu0.4~1.1

Maximum Solder Temperature: 370℃

Maximum Solder Time: 3s at the maximum temperature

Recommended Soldering Temp: 350±20℃

Typical Soldering Time: ≤3s

13.4.1.3 Solder Wetting

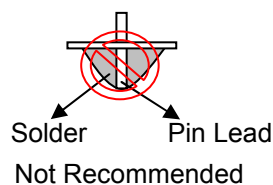
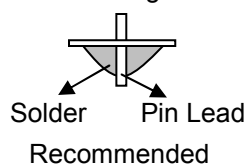

13.4.2 Pins of EL

13.4.2.1 Solder tip can touch and press on the tip of EL leads during soldering.

13.4.2.2 No Solder Paste on the soldering pad on the motherboard is recommended.

13.4.2.3 Recommended Soldering Conditions

Solder type: Nippon Alimit Leadfree SR-34, size 0.5mm

Recommended Solder Temperature: 270~290℃

Typical Soldering Time: ≤2s

Minimum solder distance from EL lamp (body):2.0mm

13.4.2.4 No horizontal press on the EL leads during soldering.

13.4.2.5 180° bend EL leads three times is not allowed.

13.4.2.6 Solder Wetting

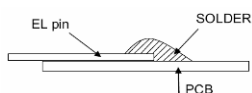

Recommended



Not Recommended

13.4.2.7 The type of the solder iron:

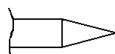

Recommended

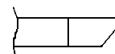

Not Recommended

13.4.2.8 Solder Pad

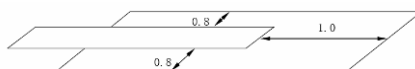

13.5.Operation

- 13.5.1. Do not drive LCD with DC voltage
- 13.5.2. Response time will increase below lower temperature
- 13.5.3. Display may change color with different temperature
- 13.5.4. Mechanical disturbance during operation, such as pressing on the display area, may cause the segments to appear "fractured".
- 13.5.5. Do not connect or disconnect the LCM to or from the system when power is on.
- 13.5.6. Never use the LCM under abnormal condition of high temperature and high humidity.
- 13.5.7. Module has high frequency circuits. Sufficient suppression to the electromagnetic interface shall be done by system manufacturers. Grounding and shielding methods may be important to minimize the interference.
- 13.5.8. Do not display the fixed pattern for long time (we suggest the time not longer than one hour) because it may develop image sticking due to the TFT structure.

13.6.Static Electricity

- 13.5.1 CMOS LSIs are equipped in this unit, so care must be taken to avoid the electro-static charge, by ground human body, etc.
- 13.5.2 The normal static prevention measures should be observed for work clothes and benches.
- 13.5.3 The module should be kept into anti-static bags or other containers resistant to static for storage.

13.7.Limited Warranty

- 13.7.1 Our warranty liability is limited to repair and/or replacement. We will not be responsible for any consequential loss.
- 13.7.2 If possible, we suggest customer to use up all modules in six months. If the module storage time over twelve months, we suggest that recheck it before the module be used.
- 13.7.3 After the product shipped, any product quality issues must be feedback within three months, otherwise, we will not be responsible for the subsequent or consequential events.

14. Packaging

TBD

15. Outline Drawing

