

PRODUCT SPECIFICATION

10.4" TFT LCD MODULE

MODEL: T104800600-A1TMR-001 Ver:1.2



< ◇ > Preliminary Specification

< ◆ > Finally Specification

CUSTOMER'S APPROVAL	
CUSTOMER :	
SIGNATURE:	DATE:

APPROVED BY	PM REVIEWED	PD REVIEWED	PREPARED BY

Revision History

Revision	Date	Originator	Detail	Remarks
1.0	2015.11.23	ZFY	Initial Release	
1.1	2018.04.23	ZFY	Add LED working life Modify many details	P5 P22/P23
1.2	2018.05.04	ZFY	Modify outline drawing(B)	P25

Table of Contents

No.	Item	Page
1.	General Description.....	4
2.	Module Parameter.....	4
3.	Absolute Maximum Ratings.....	4
4.	DC Characteristics	5
5.	Backlight Characteristic.....	5
5.1.	Backlight Characteristics	5
5.2.	Backlighting circuit.....	5
6.	Touch Screen Panel Specifications	6
7.	Optical Characteristics	7
7.1.	Optical Characteristics	7
7.2.	Definition of Response Time	7
7.3.	Definition of Contrast Ratio	8
7.4.	Definition of Viewing Angles	8
7.5.	Definition of Color Appearance.....	9
7.6.	Definition of Surface Luminance, Uniformity and Transmittance	9
8.	Block Diagram and Power Supply.....	10
9.	Interface Pins Definition	11
10.	AC Characteristics.....	13
10.1.	Data Timing(Under frame rate is equal to 60Hz).....	13
10.2.	AC Electrical characteristics	14
10.3.	Input Clock and Data Timing Waveform	14
11.	Quality Assurance	15
11.1.	Purpose	15
11.2.	Standard for Quality Test	15
11.3.	Nonconforming Analysis & Disposition.....	15
11.4.	Agreement Items	15
11.5.	Standard of the Product Visual Inspection	15
11.6.	Inspection Specification.....	16
11.7.	Classification of Defects	20
11.8.	Identification/marketing criteria.....	20
11.9.	Packing.....	20
12.	Reliability Specification.....	21
13.	Precautions and Warranty.....	22
13.1.	Safety	22
13.2.	Handling	22
13.3.	Storage	22
13.4.	Metal Pin (Apply to Products with Metal Pins).....	22
13.5.	Operation.....	23
13.6.	Static Electricity	23
13.7.	Limited Warranty	23
14.	Packaging.....	24
15.	Outline Drawing.....	25

1. General Description

The specification is a transmissive type color active matrix liquid crystal display (LCD) which uses amorphous thin film transistor (TFT) as switching devices. This product is composed of a TFT-LCD panel, driver ICs , RTP and a backlight unit.

2. Module Parameter

Features	Details	Unit
Display Size(Diagonal)	10.4"	
LCD type	TN TFT	
Display Mode	Normally White/Transmissive	
Resolution	800 RGB x 600	Pixels
View Direction	12 O'clock	Best Image
Gray Scale Inversion Direction	6 O'clock	
Module Outline	228.4(H) x 175.4(V) x 7.6(T) (Note1)	mm
Active Area	211.20 (H) x 158.40(V)	mm
Pixel Pitch	264(H) x 264(V)	um
Pixel Arrangement	RGB-Stripe	
Display Colors	16M	
Interface	24bit RGB	
With or without touch panel	With	-
Operating Temperature	-10~50	°C
Storage Temperature	-20~60	°C
Weight	TBD	g

Note 1: Exclusive hooks, posts, FFC/FPC tail etc.

3. Absolute Maximum Ratings

$V_{SS}=0V$, $T_a=25^{\circ}C$

Item	Symbol	Min.	Max.	Unit
Logic Supply Voltage	VCC	-0.3	5.0	V
Storage temperature	T_{STG}	-20	+60	°C
Operating temperature	T_{OP}	-10	+50	°C

Note 1: If T_a below $50^{\circ}C$, the maximal humidity is 90%RH, if T_a over $50^{\circ}C$, absolute humidity should be less than 60%RH.

Note 2: The response time will be extremely slow when the operating temperature is around $-10^{\circ}C$, and the back ground will become darker at high temperature operating.

4. DC Characteristics

Item	Symbol	Min.	Typ.	Max.	Unit
Digital Power Supply Voltage	VCC	3.0	3.3	3.6	V
Digital Supply Current(Black Pattern)	I _{CC}	-	6	12	mA
Analog Power Supply Voltage	AVDD	10.3	10.5	10.7	V
Analog Supply Current(Black Pattern)	I _{AVDD}	32	40	60	mA
TFT Device on voltage	V _{GH}	-	18	-	V
TFT Device off voltage	V _{GL}	-	-7	-	V
Common Electrode Driving Voltage	VCOM	4.15	4.45	4.75	V
Low Level Input Voltage	VIL	0	-	0.3*VCC	V
High Level Input Voltage	VIH	0.7*VCC	-	VCC	V

5. Backlight Characteristic

5.1. Backlight Characteristics

Item	Symbol	Condition	Min.	Typ.	Max.	Unit
Forward Voltage	V _F	T _a =25 °C, I _F =20mA/LED	-	9.6	10.5	V
Forward Current	I _F	T _a =25 °C, V _F =3.2V/LED	-	240	-	mA
Power dissipation	P _D		-	2.304	2.52	W
Uniformity	Avg		-	80	-	%
LED working life(25°C)	-		-	20000	-	Hrs
Drive method	Constant current					
LED Configuration	36 White LEDs (3 LEDs in string and 12groups in parallel)					

Note1: LED life time defined as follows: The final brightness is at 50% of original brightness.
The environmental conducted under ambient air flow, at T_a=25±2 °C, 60%RH±5%, I_F=20mA

5.2. Backlighting circuit

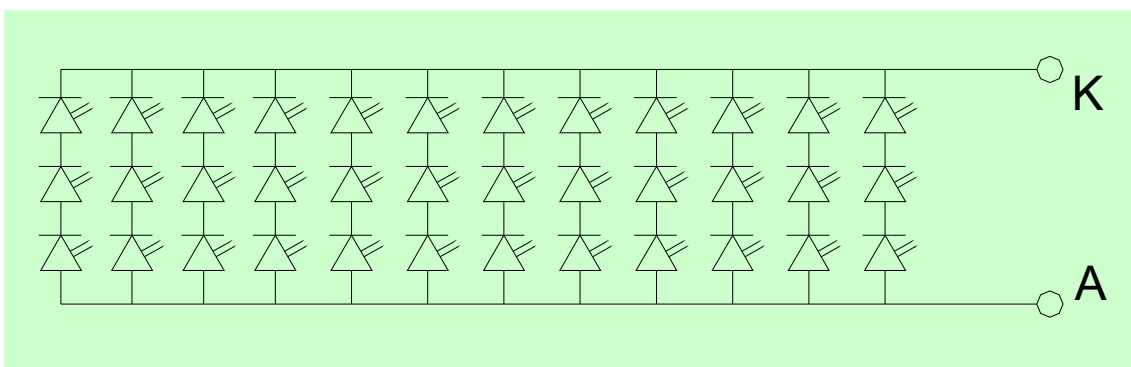

6. Touch Screen Panel Specifications

6.1 Electrical Characteristics

Item	Min.	Typ.	Max.	Unit	Note
Linearity	-3.0	-	3.0	%	Analog X and Y directions
Terminal resistance	250	-	1200	Ω	X (Film side)
	250	-	1200	Ω	Y (Glass side)
Insulation resistance	20	-	-	M Ω	DC \leq 10V
Voltage	-	-	10	V	DC
Chattering	-	-	10	ms	

Caution (1) : Do not operate it with a thing except a polyacetal pen (tip R0.8mm or less) or a finger nail, especially those with hard or sharp tips such as a ball point pen or a mechanical pencil.

Caution (2) : RTP operation must be followed the parameter condition.

Caution (3) : If ask for use glare ITO film , it's will has newton issue

6.2 Mechanical & Reliability Characteristics

Item	Min.	Typ.	Max.	Unit	Note
Activation force	30	-	100	g	(1)
Durability-surface scratching	Write 20,000	-	-	characters	(2)
Durability-surface pitting	1,000,000	-	-	touches	(3)
Surface hardness	3	-	-	H	

Note (1) Stylus pen Input R0.8mm polyacetal pen or Finger nail

Note (2) Measurement for Surface area

- Force: 150-250gf
- Speed: 60mm/sec
- Stylus: R0.8 polyacetal pen or Finger nail

Note (3) Pit 1,000,000 times on the Film with a R3.75 silicon rubber.

- Force: Force: 2.45N
- Speed: 3times/sec

7. Optical Characteristics

7.1. Optical Characteristics

$T_a=25^{\circ}\text{C}$, $V_{DD}=3.3\text{V}$

	Item	Symbol	Condition	Specification			Unit	
				Min.	Typ.	Max.		
Backlight On (Transmissive Mode)	Luminance on TFT($I_f=20\text{mA/LED}$)	Lv		160	195	-	cd/m ²	
	Contrast ratio(See 6.3)	CR		300	500	-		
	Response time (See 6.2)	T_{R+TF}		-	25	50	ms	
	Chromaticity Transmissive (See 6.5)	Red	X _R			(0.573)		
			Y _R			(0.350)		
		Green	X _G				(0.336)	
			Y _G				(0.597)	
		Blue	X _B				(0.152)	
			Y _B				(0.112)	
	White	X _W				(0.31)		
Y _W					(0.33)			
Viewing Angle (See 6.4)	Horizontal	θ_{x+}	Center CR ≥ 10	60	70	-	Deg.	
		θ_{x-}		60	70	-		
	Vertical	ϕ_{y+}		40	50	-		
		ϕ_{y-}		50	60	-		
	NTSC Ratio(Gamut)			-	50	-	%	

7.2. Definition of Response Time

7.2.1. Normally Black Type (Negative)

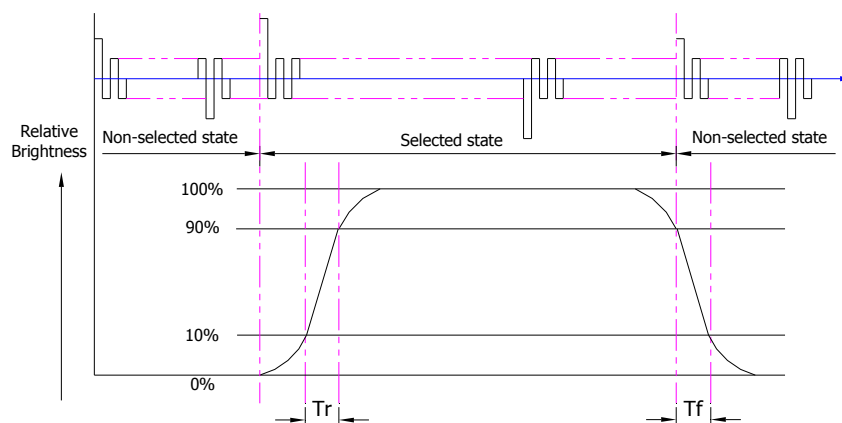

T_r is the time it takes to change from non-selected state with relative luminance 10% to selected state with relative luminance 90%;

T_f is the time it takes to change from selected state with relative luminance 90% to non-selected state with relative luminance 10%.

Note : Measuring machine: LCD-5100

7.2.2. Normally White Type (Positive)

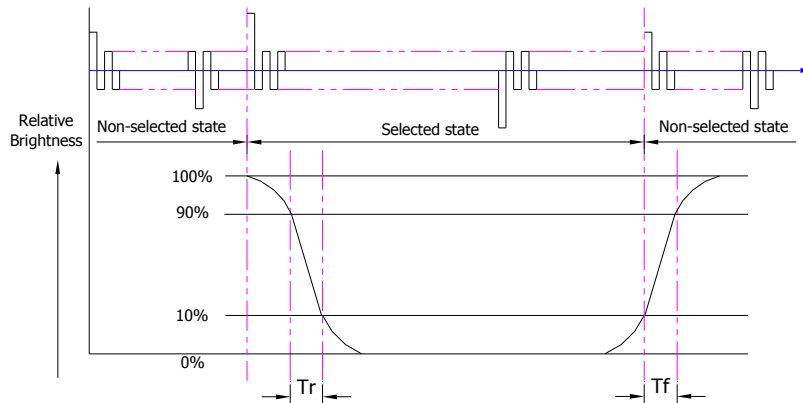

Tr is the time it takes to change from non-selected stage with relative luminance 90% to selected state with relative luminance 10%;

Tf is the time it takes to change from selected state with relative luminance 10% to non-selected state with relative luminance 90%;

Note : Measuring machine: LCD-5100 or EQUI

7.3. Definition of Contrast Ratio

Contrast is measured perpendicular to display surface in reflective and transmissive mode.

The measurement condition is:

Measuring Equipment	Eldim or Equivalent
Measuring Point Diameter	3mm//1mm
Measuring Point Location	Active Area centre point
Test pattern	A: All Pixels white
	B: All Pixel black
Contrast setting	Maximum

Definitions: CR (Contrast) = Luminance of White Pixel / Luminance of Black Pixel

7.4. Definition of Viewing Angles

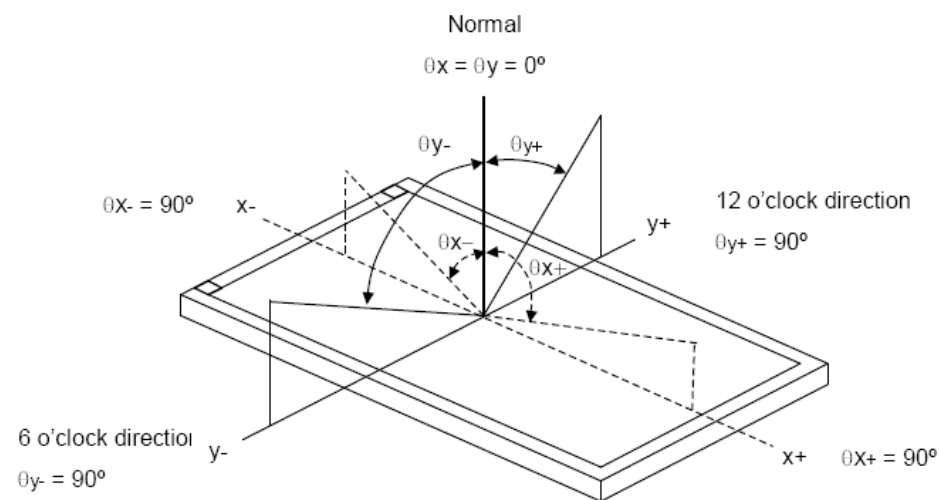

Measuring machine: LCD-5100 or EQUI

7.5. Definition of Color Appearance

R,G,B and W are defined by (x, y) on the IE chromaticity diagram

NTSC=area of RGB triangle/area of NTSC triangleX100%

Measuring picture: Red, Green, Blue and White (Measuring machine: BM-7)

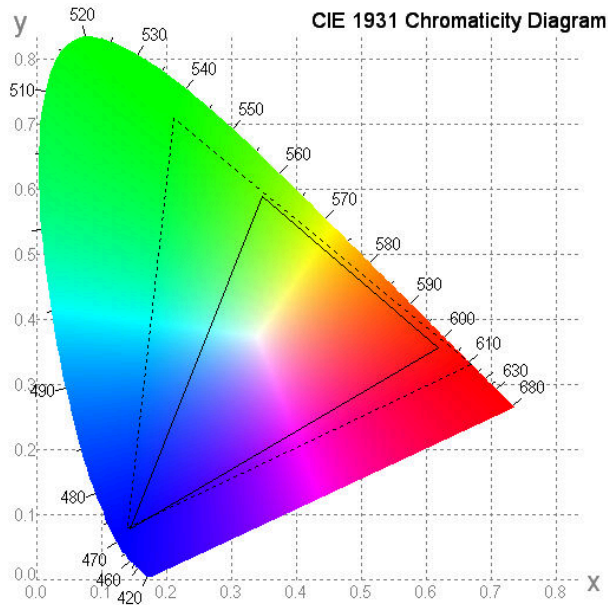

7.6. Definition of Surface Luminance, Uniformity and Transmittance

Using the transmissive mode measurement approach, measure the white screen luminance of the display panel and backlight.

7.6.1. Surface Luminance: $L_V = \text{average } (L_{P1}:L_{P9})$

7.6.2. Uniformity = Minimal ($L_{P1}:L_{P9}$) / Maximal ($L_{P1}:L_{P9}$) * 100%

7.6.3. Transmittance = L_V on LCD / L_V on Backlight * 100%

Note : Measuring machine: BM-7

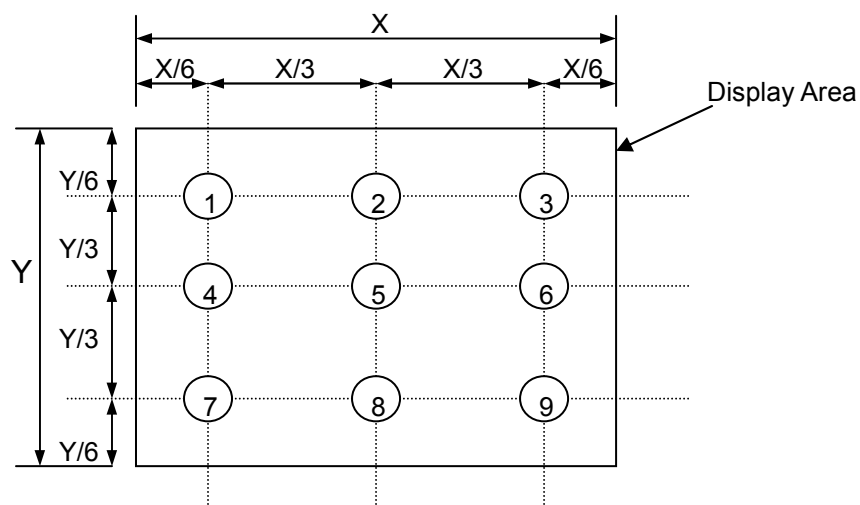

8. Block Diagram and Power Supply

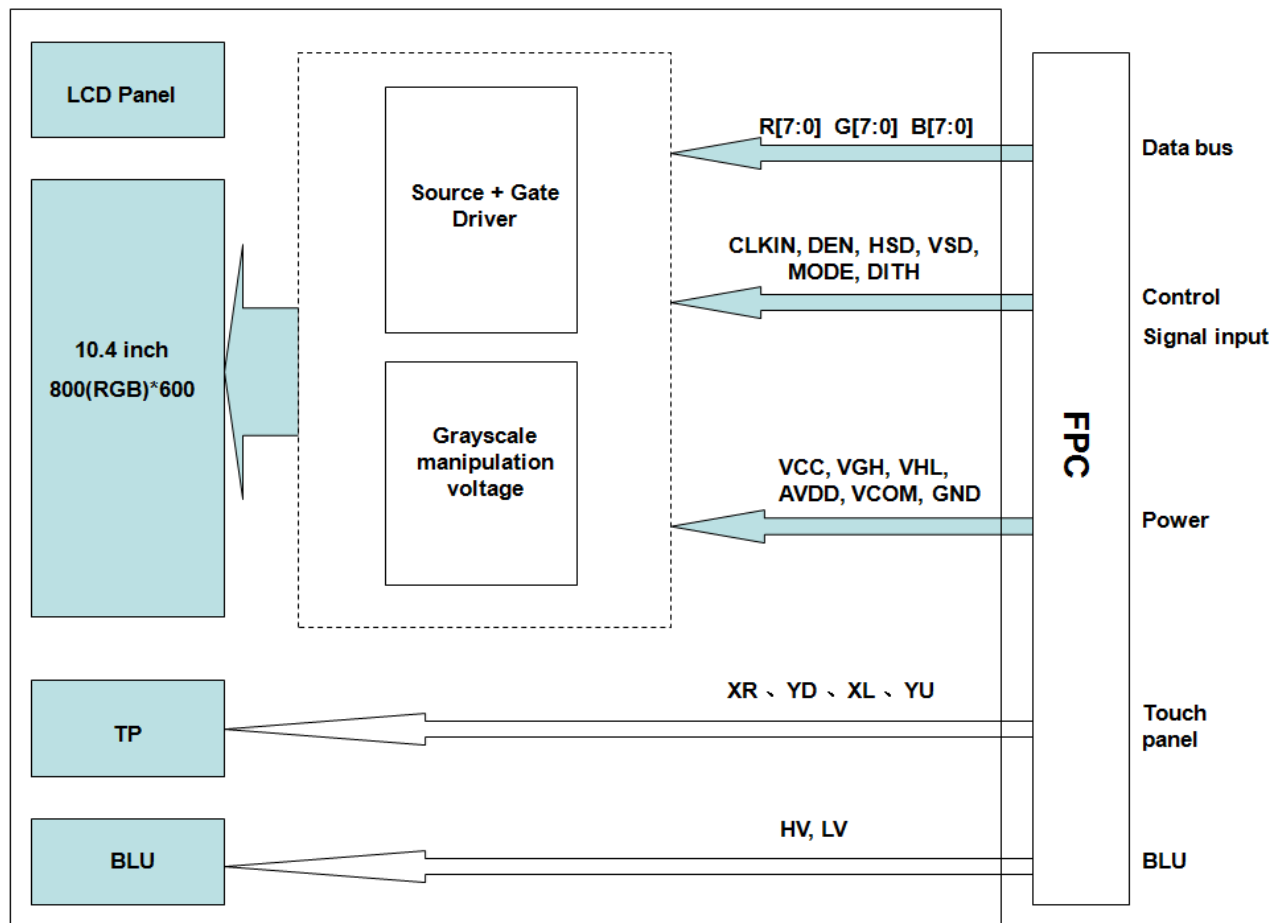

9. Interface Pins Definition

FPC CON

No.	Symbol	Function	Remark
1	GND	Ground	
2	AVDD	Analog input voltage	
3	VCC	Digital input voltage	
4	R0	Red data input(LSB)	
5	R1	Red data input	
6	R2	Red data input	
7	R3	Red data input	
8	R4	Red data input	
9	R5	Red data input	
10	R6	Red data input	
11	R7	Red data input(MSB)	
12	G0	Green data input(LSB)	
13	G1	Green data input	
14	G2	Green data input	
15	G3	Green data input	
16	G4	Green data input	
17	G5	Green data input	
18	G6	Green data input	
19	G7	Green data input(MSB)	
20	B0	Blue data input(LSB)	
21	B1	Blue data input	
22	B2	Blue data input	
23	B3	Blue data input	
24	B4	Blue data input	
25	B5	Blue data input	
26	B6	Blue data input	
27	B7	Blue data input(MSB)	
28	CLKIN	Dot clock input	
29	DEN	Data enable signal	
30	HSD	HSYNC signal	
31	VSD	VSYNC signal	
32	MODE	H:DE mode(Default) L:SYNC mode	
33	NC	No connection	
34	NC	No connection	
35	NC	No connection	
36	VCC	Digital input voltage	
37	NC	No connection	
38	GND	Ground	

39	GND	Ground	
40	AVDD	Analog input voltage	
41	VCOM	VCOM DC input	
42	DITH	Dithering function setting H:Disable dithering function L:Enable dithering function	
43	NC	No connection	
44	VCOM _{OUT}	Connec a capacitor	
45	NC	No connection	
46	NC	No connection	
47	NC	No connection	
48	NC	No connection	
49	NC	No connection	
50	NC	No connection	
51	NC	No connection	
52	NC	No connection	
53	NC	No connection	
54	NC	No connection	
55	NC	No connection	
56	VGH	TFT turn on voltage	
57	VCC	Digital input voltage	
58	VGL	TFT turn off voltage	
59	GND	Ground	
60	NC	No connection	

Backlight:

No.	Pin assignment	Description	Color
1	HV	High voltage	Red
2	LV	GND	White

TP PIN Assignment

No.	Symbol	Function
1	XL	Touch panel terminal.
2	YD	Touch panel terminal.
3	XR	Touch panel terminal.
4	YU	Touch panel terminal.

10. AC Characteristics

10.1.Data Timing(Under frame rate is equal to 60Hz)

Horizontal Timing

Parameter	Symbol	Spec			Unit
		Min.	Typ.	Max.	
Horizontal Display Area	thd	800			CLK
CLK Frequency	fclk	-	40	50	MHz
One Horizontal Line	th	862	1056	1200	CLK
HS Pulse Width	thpw	1	-	40	CLK
HS Back Porch	thb	46			CLK
HS Front Porch	thfp	16	210	354	CLK

Vertical Timing

Parameter	Symbol	Spec			Unit
		Min.	Typ.	Max.	
Vertical Display Area	tvd	600			th
VS Period Time	tv	624	635	700	th
VS Pulse Width	tvpw	1	-	20	th
VS Back Porch	tvb	23	23	23	th
VS Front Porch	tvfp	1	12	77	th

Note:

CMO suggest using frame rate 60Hz to have better performance

Horizontal Timing

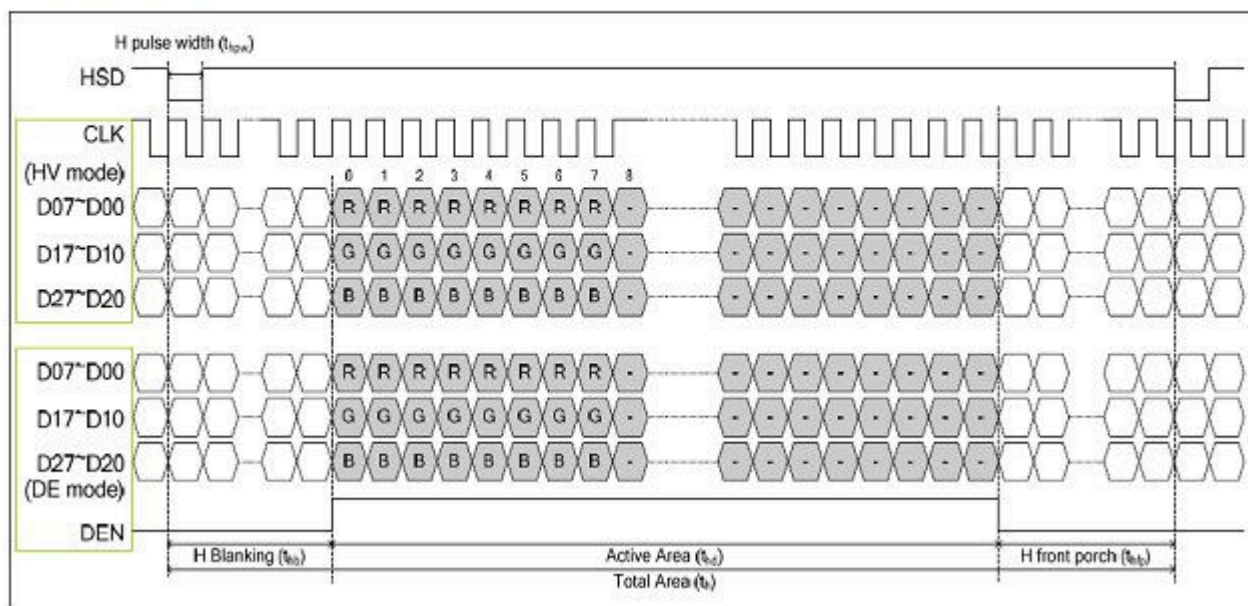

Vertical Timing

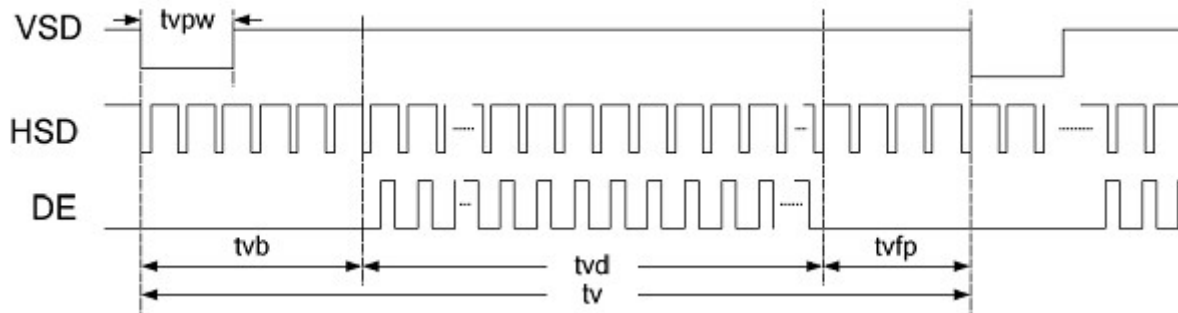

10.2.AC Electrical characteristics

Parameter	Symbol	Spec.			Unit
		Min.	Typ.	Max.	
HS setup time	T_{hst}	8	-	-	ns
HS hold time	T_{hhd}	8	-	-	ns
VS setup time	T_{vst}	8	-	-	ns
VS hold time	T_{vhd}	8	-	-	ns
Data setup time	T_{dsu}	8	-	-	ns
Data hold time	T_{dhhd}	8	-	-	ns
DE setup time	T_{esu}	8	-	-	ns
DE hold time	T_{ehd}	8	-	-	ns
VDD Power On Slew Rate	T_{POR}	-	-	20	ms
RSTB pulse width	T_{Rst}	10	-	-	us
CLKIN cycle time	T_{cph}	20	-	-	ns
CLKIN pulse duty	T_{cwh}	40	50	60	%
Output stable time	T_{sst}	-	-	6	us
Repair OPA Output Stable time	T_{Rsst}	-	-	6	ns

10.3.Input Clock and Data Timing Waveform

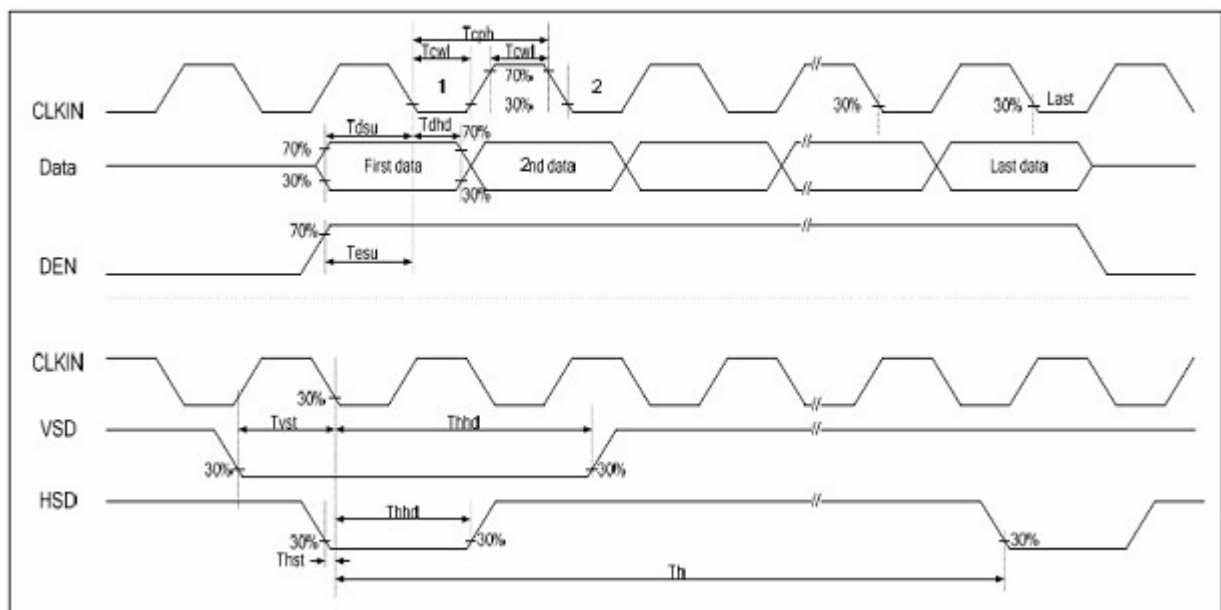

11. Quality Assurance

11.1.Purpose

This standard for Quality Assurance assures the quality of LCD module products supplied to customer.

11.2.Standard for Quality Test

11.2.1. Sampling Plan:

GB2828.1-2012

Single sampling, general inspection level II

11.2.2. Sampling Criteria:

Visual inspection: AQL 1.5%

Electrical functional: AQL 0.65%.

11.2.3. Reliability Test:

Detailed requirement refer to Reliability Test Specification.

11.3.Nonconforming Analysis & Disposition

11.3.1. Nonconforming analysis:

11.3.1.1. Customer should provide overall information of non-conforming sample for their complaints.

11.3.1.2. After receipt of detailed information from customer, the analysis of nonconforming parts usually should be finished in one week.

11.3.1.3. If can not finish the analysis on time, customer will be notified with the progress status.

11.3.2. Disposition of nonconforming:

11.3.2.1. Non-conforming product over PPM level will be replaced.

11.3.2.2. The cause of non-conformance will be analyzed. Corrective action will be discussed and implemented.

11.4.Agreement Items

Shall negotiate with customer if the following situation occurs:

11.4.1. There is any discrepancy in standard of quality assurance.

11.4.2. Additional requirement to be added in product specification.

11.4.3. Any other special problem.

11.5.Standard of the Product Visual Inspection

11.5.1. Appearance inspection:

11.5.1.1. The inspection must be under illumination about 1000 – 1500 lx, and the distance of view must be at 30cm ± 2cm.

11.5.1.2. The viewing angle should be 45° from the vertical line without reflection light or follows customer's viewing angle specifications.

11.5.1.3. Definition of area: A Zone: Active Area, B Zone: Viewing Area,

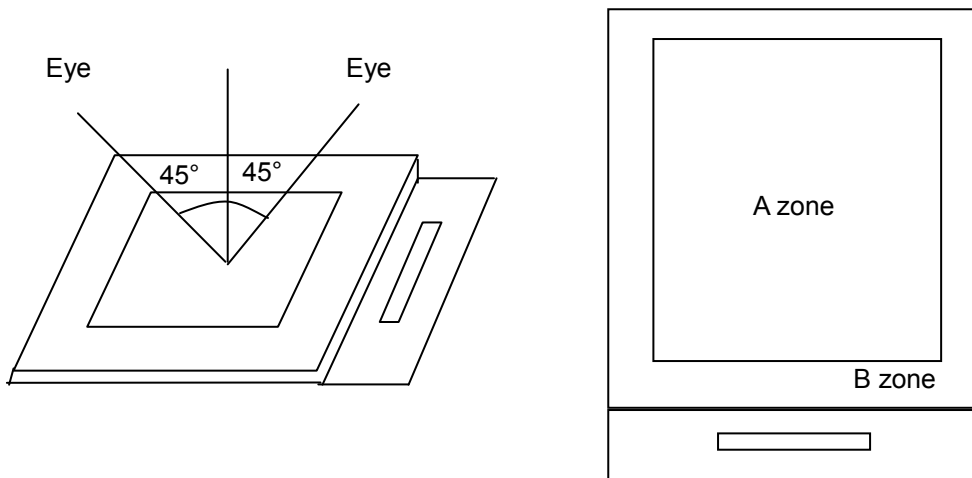

11.5.2. Basic principle:

11.5.2.1. A set of sample to indicate the limit of acceptable quality level must be discussed by both us and customer when there is any dispute happened.

11.5.2.2. New item must be added on time when it is necessary.

11.6. Inspection Specification

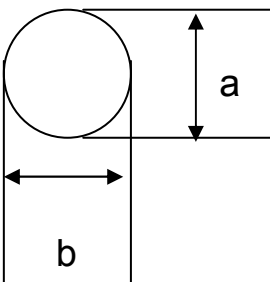
No.	Item	Criteria (Unit: mm)																
01	Black / White spot Foreign material (Round type) Pinholes Stain Particles inside cell. (Minor defect)	 <table border="1" data-bbox="917 1198 1420 1422"> <thead> <tr> <th>Size</th> <th>Area</th> <th>Acc. Qty</th> </tr> </thead> <tbody> <tr> <td>$\varphi \leq 0.20$</td> <td></td> <td>Ignore</td> </tr> <tr> <td>$0.20 < \varphi \leq 0.50$</td> <td></td> <td>$N \leq 3$</td> </tr> <tr> <td>$0.50 < \varphi$</td> <td></td> <td>0</td> </tr> </tbody> </table> <p>$\varphi = (a + b) / 2$ Distance between 2 defects should more than 5mm apart.</p>	Size	Area	Acc. Qty	$\varphi \leq 0.20$		Ignore	$0.20 < \varphi \leq 0.50$		$N \leq 3$	$0.50 < \varphi$		0				
Size	Area	Acc. Qty																
$\varphi \leq 0.20$		Ignore																
$0.20 < \varphi \leq 0.50$		$N \leq 3$																
$0.50 < \varphi$		0																
02	Electrical Defect (Minor defect)	<table border="1" data-bbox="550 1635 1420 1848"> <thead> <tr> <th rowspan="2">Bright dot</th> <th>Display Area</th> <th>Total</th> <th rowspan="3">Note1</th> </tr> </thead> <tbody> <tr> <td>$N \leq 2$</td> <td>$N \leq 2$</td> </tr> <tr> <th>Dark dot</th> <td>$N \leq 4$</td> <td>$N \leq 4$</td> </tr> <tr> <th>Total dot</th> <td>$N \leq 4$</td> <td>$N \leq 4$</td> </tr> <tr> <th>Mura</th> <td colspan="2">Not visible through 5% ND filters.</td> <td>Note 2</td> </tr> </tbody> </table> <p>Remark: 1. Bright dot caused by scratch and foreign object accords to item 1.</p>	Bright dot	Display Area	Total	Note1	$N \leq 2$	$N \leq 2$	Dark dot	$N \leq 4$	$N \leq 4$	Total dot	$N \leq 4$	$N \leq 4$	Mura	Not visible through 5% ND filters.		Note 2
Bright dot	Display Area	Total		Note1														
	$N \leq 2$	$N \leq 2$																
Dark dot	$N \leq 4$	$N \leq 4$																
Total dot	$N \leq 4$	$N \leq 4$																
Mura	Not visible through 5% ND filters.		Note 2															

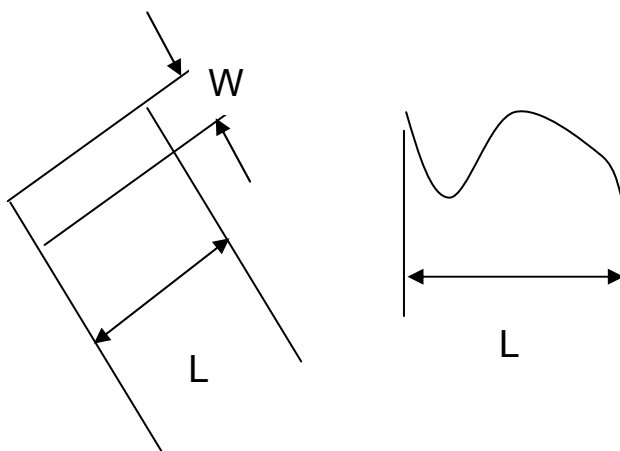
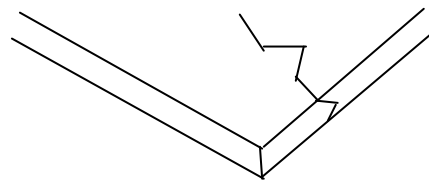
<p>03</p>	<p>Black and White line Scratch Foreign material (Line type) (Minor defect)</p>	 <table border="1" data-bbox="614 750 1236 1008"> <thead> <tr> <th>Length</th> <th>Width</th> <th>Acc. Qty</th> </tr> </thead> <tbody> <tr> <td>/</td> <td>$W \leq 0.1$</td> <td>Ignore</td> </tr> <tr> <td>$L \leq 2.5$</td> <td>$0.1 < W \leq 0.2$</td> <td>3</td> </tr> <tr> <td>$L > 2.5$</td> <td>$0.2 < W$</td> <td>0</td> </tr> <tr> <td colspan="2">Total</td> <td>3</td> </tr> </tbody> </table> <p>Distance between 2 defects should more than 3mm apart. Scratches not viewable through the back of the display are acceptable.</p>	Length	Width	Acc. Qty	/	$W \leq 0.1$	Ignore	$L \leq 2.5$	$0.1 < W \leq 0.2$	3	$L > 2.5$	$0.2 < W$	0	Total		3
Length	Width	Acc. Qty															
/	$W \leq 0.1$	Ignore															
$L \leq 2.5$	$0.1 < W \leq 0.2$	3															
$L > 2.5$	$0.2 < W$	0															
Total		3															
<p>04</p>	<p>Glass Crack (Minor defect)</p>	 <p>Crack is potential to enlarge, any type is not allowed.</p>															

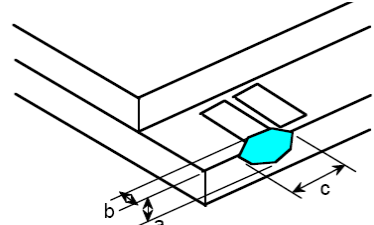
<p>05</p>	<p>Glass Chipping Pad Area: (Minor defect)</p> 	<table border="1" data-bbox="861 1724 1332 1892"> <thead> <tr> <th>Length and Width</th> <th>Acc. Qty</th> </tr> </thead> <tbody> <tr> <td>$c > 3.0, b < 1.0$</td> <td>1</td> </tr> <tr> <td>$c < 3.0, b < 1.0$</td> <td>3</td> </tr> <tr> <td colspan="2">$a < \text{Glass Thickness}$</td> </tr> </tbody> </table>	Length and Width	Acc. Qty	$c > 3.0, b < 1.0$	1	$c < 3.0, b < 1.0$	3	$a < \text{Glass Thickness}$	
Length and Width	Acc. Qty									
$c > 3.0, b < 1.0$	1									
$c < 3.0, b < 1.0$	3									
$a < \text{Glass Thickness}$										

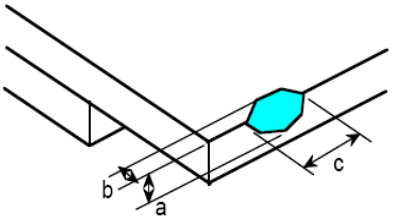
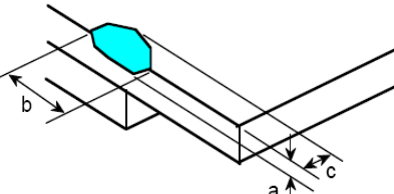
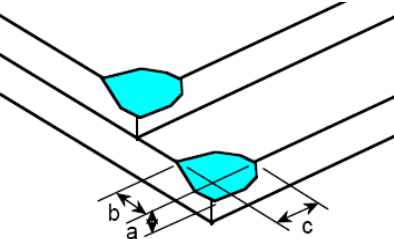
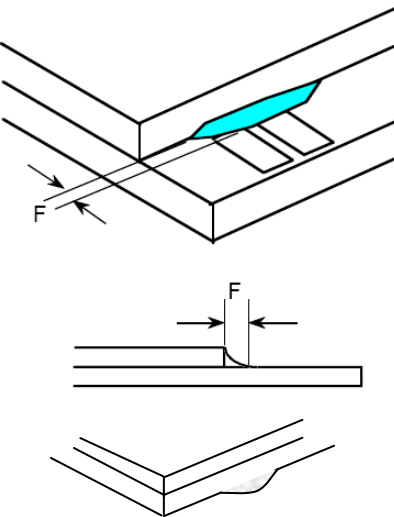
<p>06</p>	<p>Glass Chipping Rear of Pad Area: (Minor defect)</p> 	<table border="1"> <thead> <tr> <th>Length and Width</th> <th>Acc. Qty</th> </tr> </thead> <tbody> <tr> <td>$c > 3.0, b < 1.0$</td> <td>1</td> </tr> <tr> <td>$c < 3.0, b < 1.0$</td> <td>2</td> </tr> <tr> <td>$c < 3.0, b < 0.5$</td> <td>4</td> </tr> <tr> <td colspan="2" style="text-align: center;">$a < \text{Glass Thickness}$</td> </tr> </tbody> </table>	Length and Width	Acc. Qty	$c > 3.0, b < 1.0$	1	$c < 3.0, b < 1.0$	2	$c < 3.0, b < 0.5$	4	$a < \text{Glass Thickness}$	
Length and Width	Acc. Qty											
$c > 3.0, b < 1.0$	1											
$c < 3.0, b < 1.0$	2											
$c < 3.0, b < 0.5$	4											
$a < \text{Glass Thickness}$												
<p>07</p>	<p>Glass Chipping Except Pad Area: (Minor defect)</p> 	<table border="1"> <thead> <tr> <th>Length and Width</th> <th>Acc. Qty</th> </tr> </thead> <tbody> <tr> <td>$c > 3.0, b < 1.0$</td> <td>1</td> </tr> <tr> <td>$c < 3.0, b < 1.0$</td> <td>2</td> </tr> <tr> <td>$c < 3.0, b < 0.5$</td> <td>4</td> </tr> <tr> <td colspan="2" style="text-align: center;">$a < \text{Glass Thickness}$</td> </tr> </tbody> </table>	Length and Width	Acc. Qty	$c > 3.0, b < 1.0$	1	$c < 3.0, b < 1.0$	2	$c < 3.0, b < 0.5$	4	$a < \text{Glass Thickness}$	
Length and Width	Acc. Qty											
$c > 3.0, b < 1.0$	1											
$c < 3.0, b < 1.0$	2											
$c < 3.0, b < 0.5$	4											
$a < \text{Glass Thickness}$												
<p>08</p>	<p>Glass Corner Chipping: (Minor defect)</p> 	<table border="1"> <thead> <tr> <th>Length and Width</th> <th>Acc. Qty</th> </tr> </thead> <tbody> <tr> <td>$c < 3.0, b < 3.0$</td> <td>Ignore</td> </tr> <tr> <td colspan="2" style="text-align: center;">$a < \text{Glass Thickness}$</td> </tr> </tbody> </table>	Length and Width	Acc. Qty	$c < 3.0, b < 3.0$	Ignore	$a < \text{Glass Thickness}$					
Length and Width	Acc. Qty											
$c < 3.0, b < 3.0$	Ignore											
$a < \text{Glass Thickness}$												
<p>09</p>	<p>Glass Burr: (Minor defect)</p> 	<table border="1"> <thead> <tr> <th>Length</th> <th>Acc. Qty</th> </tr> </thead> <tbody> <tr> <td>$F < 1.0$</td> <td>Ignore</td> </tr> </tbody> </table> <p>Glass burr don't affect assemble and module dimension.</p>	Length	Acc. Qty	$F < 1.0$	Ignore						
Length	Acc. Qty											
$F < 1.0$	Ignore											

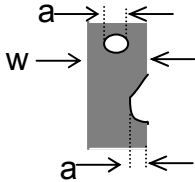
10	<p>FPC Defect: (Minor defect)</p> 	<p>10.1 Dent, pinhole width $a < w/3$. (w: circuitry width.) 10.2 Open circuit is unacceptable. 10.3 No oxidation, contamination and distortion.</p>								
11	Bubble on Polarizer (Minor defect)	<table border="1" data-bbox="737 577 1206 748"> <thead> <tr> <th>Diameter</th> <th>Acc. Qty</th> </tr> </thead> <tbody> <tr> <td>$\varphi \leq 0.30$</td> <td>Ignore</td> </tr> <tr> <td>$0.30 < \varphi \leq 0.50$</td> <td>$N \leq 2$</td> </tr> <tr> <td>$0.50 < \varphi$</td> <td>$N=0$</td> </tr> </tbody> </table>	Diameter	Acc. Qty	$\varphi \leq 0.30$	Ignore	$0.30 < \varphi \leq 0.50$	$N \leq 2$	$0.50 < \varphi$	$N=0$
Diameter	Acc. Qty									
$\varphi \leq 0.30$	Ignore									
$0.30 < \varphi \leq 0.50$	$N \leq 2$									
$0.50 < \varphi$	$N=0$									
12	Dent on Polarizer (Minor defect)	<table border="1" data-bbox="737 801 1206 972"> <thead> <tr> <th>Diameter</th> <th>Acc. Qty</th> </tr> </thead> <tbody> <tr> <td>$\varphi \leq 0.25$</td> <td>Ignore</td> </tr> <tr> <td>$0.25 < \varphi \leq 0.50$</td> <td>$N \leq 4$</td> </tr> <tr> <td>$0.50 < \varphi$</td> <td>None</td> </tr> </tbody> </table>	Diameter	Acc. Qty	$\varphi \leq 0.25$	Ignore	$0.25 < \varphi \leq 0.50$	$N \leq 4$	$0.50 < \varphi$	None
Diameter	Acc. Qty									
$\varphi \leq 0.25$	Ignore									
$0.25 < \varphi \leq 0.50$	$N \leq 4$									
$0.50 < \varphi$	None									
13	Bezel	<p>13.1 No rust, distortion on the Bezel. 13.2 No visible fingerprints, stains or other contamination.</p>								
14	Touch Panel	<p>D: Diameter W: width L: length 14.1 Spot: $D < 0.25$ is acceptable $0.25 \leq D \leq 0.4$ 2dots are acceptable and the distance between defects should more than 10 mm. $D > 0.4$ is unacceptable 14.2 Dent: $D > 0.40$ is unacceptable 14.3 Scratch: $W \leq 0.03, L \leq 10$ is acceptable, $0.03 < W \leq 0.10, L \leq 10$ is acceptable Distance between 2 defects should more than 10 mm. $W > 0.10$ is unacceptable.</p>								
15	LCD Ripple	<p>Touch the touch panel, cannot see the LCD ripple. Pen: R 0.8mm silicon rubber. Operation Force:120g</p>								
16	PCB	<p>15.1 No distortion or contamination on PCB terminals. 15.2 All components on PCB must same as documented on the BOM/component layout. 15.3 Follow IPC-A-600F.</p>								
17	Soldering	Follow IPC-A-610C standard								

18	Electrical Defect (Major defect)	<p>The below defects must be rejected.</p> <p>17.1 Missing vertical / horizontal segment, 17.2 Abnormal Display. 17.3 No function or no display. 17.4 Current exceeds product specifications. 17.5 LCD viewing angle defect. 17.6 No Backlight. 17.7 Dark Backlight. 17.8 Touch Panel no function.</p>
----	-------------------------------------	--

Remark: LCD Panel Broken shall be rejected. Defect out of LCD viewing area is acceptable.

11.7. Classification of Defects

11.7.1. Visual defects (Except no / wrong label) are treated as minor defect and electrical defect is major.

11.7.2. Two minor defects are equal to one major in lot sampling inspection.

11.8. Identification/marketing criteria

Any unit with illegible / wrong /double or no marking/ label shall be rejected.

11.9. Packing

11.9.1. There should be no damage of the outside carton box, each packaging box should have one identical label.

11.9.2. Modules inside package box should have compliant mark.

11.9.3. All direct package materials shall offer ESD protection

Note1: Bright dot is defined as the defective area of the dot is larger than 50% of one sub-pixel area.

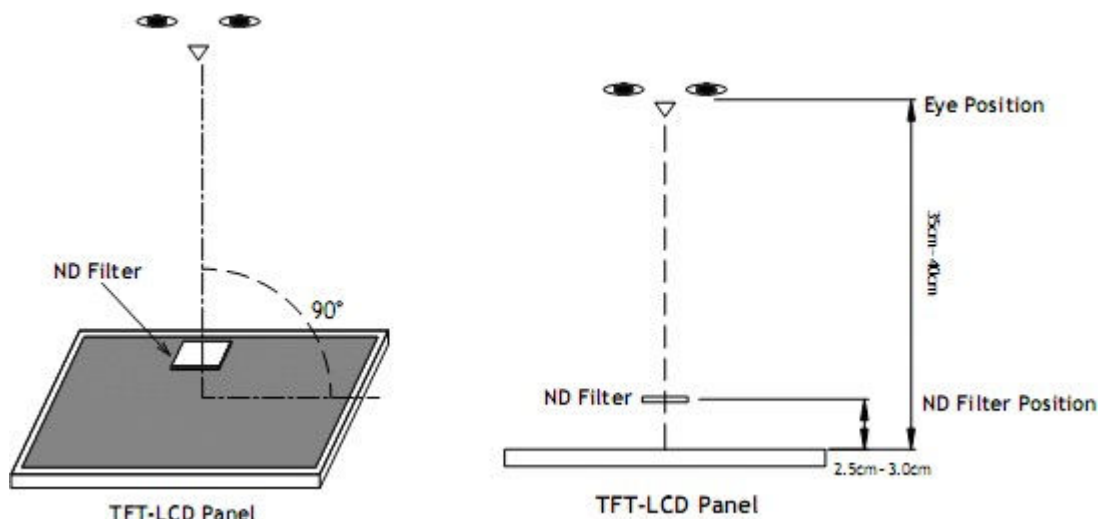

Bright dot: The bright dot size defect at black display pattern. It can be recognized by 2% transparency of filter when the distance between eyes and panel is $350\text{mm} \pm 50\text{mm}$.

Dark dot: Cyan, Magenta or Yellow dot size defect at white display pattern. It can be recognized by 5% transparency of filter when the distance between eyes and panel is $350\text{mm} \pm 50\text{mm}$.

Note2: Mura on display which appears darker / brighter against background brightness on parts of display area.

12. Reliability Specification

No	Item	Condition	Quantity	Criteria
1	High Temperature Operating	50°C, 96Hrs	2	GB/T2423.2-2008
2	Low Temperature Operating	-10°C, 96Hrs	2	GB/T2423.1-2008
3	High Humidity	40°C, 90%RH, 96Hrs	2	GB/T2423.3-2006
4	High Temperature Storage	60°C, 96Hrs	2	GB/T2423.2-2008
5	Low Temperature Storage	-20°C, 96Hrs	2	GB/T2423.1-2008
6	Thermal Cycling Test	-10°C, 60min~50°C, 60min, 20 cycles.	2	GB/T2423.22-2012
7	Packing vibration	Frequency range:10Hz~50Hz Acceleration of gravity:5G X,Y,Z 30 min for each direction.	2	GB/T5170.14-2009
8	Drop Test (Packaged)	Height:80 cm,1 corner, 3 edges, 6 surfaces.	2	GB/T2423.8-1995

Note1. No deflection cosmetic and operational function allowable.

Note2. Total current Consumption should be below double of initial value

13. Precautions and Warranty

13.1. Safety

13.1.1 The liquid crystal in the LCD is poisonous. Do not put it in your mouth. If the liquid crystal touches your skin or clothes, wash it off immediately using soap and water.

13.1.2 Since the liquid crystal cells are made of glass, do not apply strong impact on them. Handle with care.

13.2. Handling

13.2.1 Reverse and use within ratings in order to keep performance and prevent damage.

13.2.2 Do not wipe the polarizer with dry cloth, as it might cause scratch. If the surface of the LCD needs to be cleaned, wipe it swiftly with cotton or other soft cloth soaked with petroleum IPA, do not use other chemicals.

13.3. Storage

13.3.1. Do not store the LCD module beyond the specified temperature ranges.

13.3.2. Strong light exposure causes degradation of polarizer and color filter

13.4. Metal Pin (Apply to Products with Metal Pins)

13.4.1 Pins of LCD and Backlight

13.4.1.1 Solder tip can touch and press on the tip of Pin LEAD during the soldering

13.4.1.2 Recommended Soldering Conditions

Solder Type: Sn96.3~94-Ag3.3~4.3-Cu0.4~1.1

Maximum Solder Temperature: 370℃

Maximum Solder Time: 3s at the maximum temperature

Recommended Soldering Temp: 350±20℃

Typical Soldering Time: ≤3s

13.4.1.3 Solder Wetting

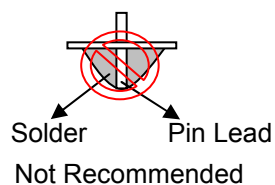
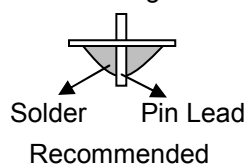

13.4.2 Pins of EL

13.4.2.1 Solder tip can touch and press on the tip of EL leads during soldering.

13.4.2.2 No Solder Paste on the soldering pad on the motherboard is recommended.

13.4.2.3 Recommended Soldering Conditions

Solder type: Nippon Alimit Leadfree SR-34, size 0.5mm

Recommended Solder Temperature: 270~290℃

Typical Soldering Time: ≤2s

Minimum solder distance from EL lamp (body):2.0mm

13.4.2.4 No horizontal press on the EL leads during soldering.

13.4.2.5 180° bend EL leads three times is not allowed.

13.4.2.6 Solder Wetting

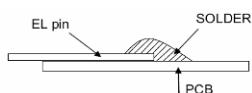

Recommended



Not Recommended

13.4.2.7 The type of the solder iron:

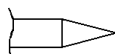

Recommended

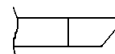

Not Recommended

13.4.2.8 Solder Pad

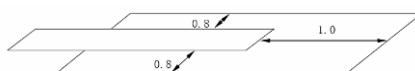

13.5. Operation

- 13.5.1. Do not drive LCD with DC voltage
- 13.5.2. Response time will increase below lower temperature
- 13.5.3. Display may change color with different temperature
- 13.5.4. Mechanical disturbance during operation, such as pressing on the display area, may cause the segments to appear "fractured".
- 13.5.5. Do not connect or disconnect the LCM to or from the system when power is on.
- 13.5.6. Never use the LCM under abnormal condition of high temperature and high humidity.
- 13.5.7. Module has high frequency circuits. Sufficient suppression to the electromagnetic interface shall be done by system manufacturers. Grounding and shielding methods may be important to minimize the interference.
- 13.5.8. Do not display the fixed pattern for long time (we suggest the time not longer than one hour) because it may develop image sticking due to the TFT structure.

13.6. Static Electricity

- 13.6.1. CMOS LSIs are equipped in this unit, so care must be taken to avoid the electro-static charge, by ground human body, etc.
- 13.6.2. The normal static prevention measures should be observed for work clothes and benches.
- 13.6.3. The module should be kept into anti-static bags or other containers resistant to static for storage.

13.7. Limited Warranty

- 13.7.1. Our warranty liability is limited to repair and/or replacement. We will not be responsible for any consequential loss.
- 13.7.2. If possible, we suggest customer to use up all modules in six months. If the module storage time over twelve months, we suggest that recheck it before the module be used
- 13.7.3. After the product shipped, any product quality issues must be feedback within three months, otherwise, we will not be responsible for the subsequent or consequential events.

14. Packaging

TBD

25/25

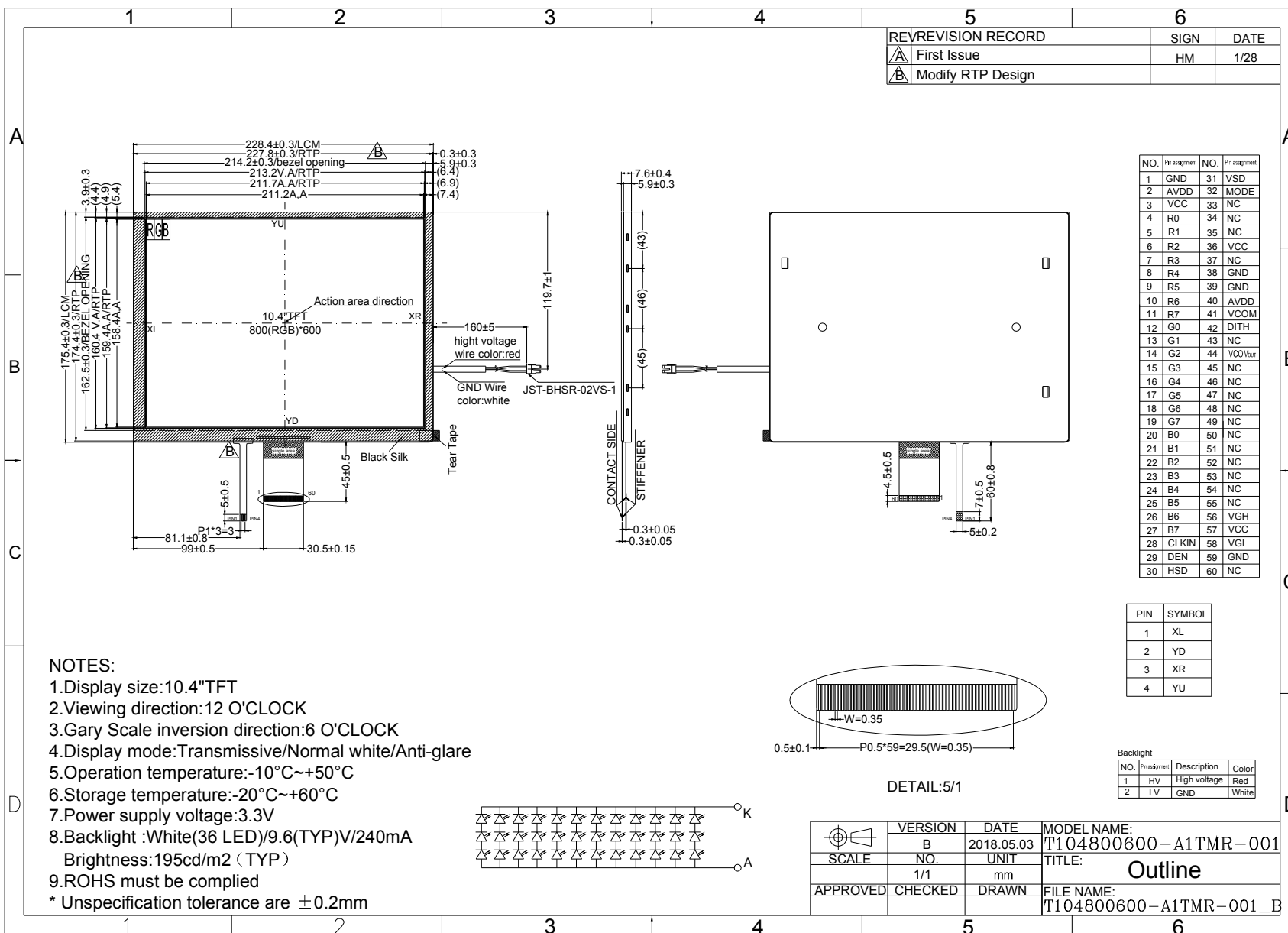

15. Outline Drawing

T104800600-A1TMR-001
Rev:1.2