

PRODUCT SPECIFICATION

10.4" TFT LCD MODULE

MODEL: T104102768-A0WMN-001 Ver:1.1



< ◇ > Preliminary Specification

< ◆ > Finally Specification

CUSTOMER'S APPROVAL	
CUSTOMER :	
SIGNATURE:	DATE:

APPROVED BY	PM REVIEWED	PD REVIEWED	PREPARED BY

Revision History

Revision	Date	Originator	Detail	Remarks
Ver 1.0	2016.10.24	ZFY	Initial Release	
1.1	2018.04.23	ZFY	Modify many details	P22/P23

Table of Contents

No.	Item	Page
1.	General Description.....	4
2.	Module Parameter.....	4
3.	Absolute Maximum Ratings.....	4
4.	DC Characteristics	5
5.	Backlight Characteristic.....	5
6.	Touch Screen Panel Specifications.....	5
7.	Optical Characteristics	6
7.1.	Optical Characteristics	6
7.2.	Definition of Response Time	6
7.3.	Definition of Contrast Ratio	7
7.4.	Definition of Viewing Angles	7
7.5.	Definition of Color Appearance.....	7
7.6.	Definition of Surface Luminance, Uniformity and Transmittance	8
8.	Block Diagram and Power Supply.....	9
9.	Interface Pins Definition	10
10.	AC characteristic	12
11.	Quality Assurance	15
11.1.	Purpose	15
11.2.	Standard for Quality Test.....	15
11.3.	Nonconforming Analysis & Disposition.....	15
11.4.	Agreement Items	15
11.5.	Standard of the Product Visual Inspection	15
11.6.	Inspection Specification.....	16
11.7.	Classification of Defects	20
11.8.	Identification/marketing criteria.....	20
11.9.	Packaging.....	20
12.	Reliability Specification.....	21
13.	Precautions and Warranty.....	22
13.1.	Safety	22
13.2.	Handling	22
13.3.	Storage	22
13.4.	Metal Pin (Apply to Products with Metal Pins)	22
13.5.	Operation.....	23
13.6.	Static Electricity	23
13.7.	Limited Warranty	23
14.	Packaging.....	24
15.	Outline Drawing.....	25

1. General Description

The specification is a transmissive type color active matrix liquid crystal display (LCD) which uses amorphous thin film transistor (TFT) as switching devices. This product is composed of a TFT-LCD panel, driver ICs and a backlight unit.

2. Module Parameter

Features	Details	Unit
Display Size(Diagonal)	10.4"	
LCD type	IPS TFT	
Display Mode	Transmissive / Normally Black	
Resolution	1024 RGB x 768	Pixels
View Direction	FULL VIEW	Best Image
Module Outline	236(H) x 174.3(V) x 7.4(T) (Note1)	mm
Active Area	211.2(H) x 158.4(V)	mm
Pixel Size	206.25 x 206.25	um
Pixel Arrangement	RGB Vertical Stripe	
Surface treatment	Antiglare	
Display Colors	16 M	
Interface	LVDS	
With or Without Touch Panel	Without	-
Operating Temperature	-20~70	°C
Storage Temperature	-30~80	°C
Weight	(500)	g

Note 1: Exclusive hooks, posts, FFC/FPC tail etc.

3. Absolute Maximum Ratings

$V_{SS}=0V, T_a=25^{\circ}C$

Item	Symbol	Min.	Max.	Unit
Supply Voltage	DVDD	-0.3	5	V
	AVDD	-0.5	15	V
	VGH	-0.3	42	V
	VGL	-20	0.3	V
	VGH-VGL	-0.3	40	V
Storage temperature	T_{STG}	-30	+80	°C
Operating temperature	T_{OP}	-20	+70	°C

Note 1: If T_a below $50^{\circ}C$, the maximal humidity is 90%RH, if T_a over $50^{\circ}C$, absolute humidity should be less than 60%RH.

Note 2: The response time will be extremely slow when the operating temperature is around $-10^{\circ}C$, and the back ground will become darker at high temperature operating.

4. DC Characteristics

Item	Symbol	Min.	Typ.	Max.	Unit
Supply Voltage	DVDD	3.0	3.3	3.6	V
	AVDD		12.1		V
	VGH		23		V
	VGL		-10		V
	VCOM		5.275		V
Input signal voltage	ViH	0.8 DVDD	-	DVDD	
	ViL	0	-	0.2DVDD	
Differential Input High/Low threshold Voltage	Vth			100	mV
	Vtl	-100			mV
Common Mode Voltage Offset	Vcm	0.7	1.2	1.6	V
Power Supply Current for LCM	IDD	-	TBD	-	mA

Note:

- (1): VGH is TFT Gate operating Voltage.
- (2): VGL is TFT Gate operating Voltage.
- (3): VCOM must be adjusted to optimize display quality _ Flicker Pattern

5. Backlight Characteristic

5.1 Backlight Characteristic

Item	Symbol	Condition	Min.	Typ.	Max.	Unit
Backlight Voltage	VLED	Ta=25 °C, I _F =240mA		15	16	V
Backlight Current	ILED	-		240		mA
Power dissipation	P _D	-	-	3600	-	W
Uniformity	Avg	-	70	80	-	%
LED working life(25°C)	-		-	30,000	-	Hrs
Drive method	Constant current					

Note 1 : LED life time defined as follows: The final brightness is at 50% of original brightness.
The environmental conducted under ambient air flow, at Ta=25±2 °C,60%RH±5%, I_F=240mA.

5.2 Backlighting circuit

TBD

6. Touch Screen Panel Specifications

WITHOUT TP

7. Optical Characteristics

7.1. Optical Characteristics

Ta=25°C, DVDD=3.3V

	Item	Symbol	Condition	Specification			Unit
				Min.	Typ.	Max.	
Backlight On (Transmissive Mode)	Luminance on TFT ($I_f=240m$)	Lv	Normally viewing angle $\theta_x = \phi_y = 0^\circ$	480	600	-	cd/m ²
	Contrast ratio(See 6.3)	CR		600	900	-	
	Response time (See 6.2)	T _R		-	30	40	ms
		T _F					
	Chromaticity Transmissive (See 6.5)	Red	X _R		TBD		
			Y _R		TBD		
		Green	X _G		TBD		
			Y _G		TBD		
		Blue	X _B		TBD		
			Y _B		TBD		
	White	X _W		0.263	0.313	0.363	
		Y _W		0.279	0.329	0.379	
	Viewing Angle (See 6.4)	Horizontal	θ_{x+}	Center CR \geq 10	80	85	-
θ_{x-}			80		85	-	
Vertical		ϕ_{y+}	80		85	-	
		ϕ_{y-}	80		85	-	
	NTSC Ratio(Gamut)			-	70	-	%

7.2. Definition of Response Time

7.2.1. Normally Black Type (Negative)

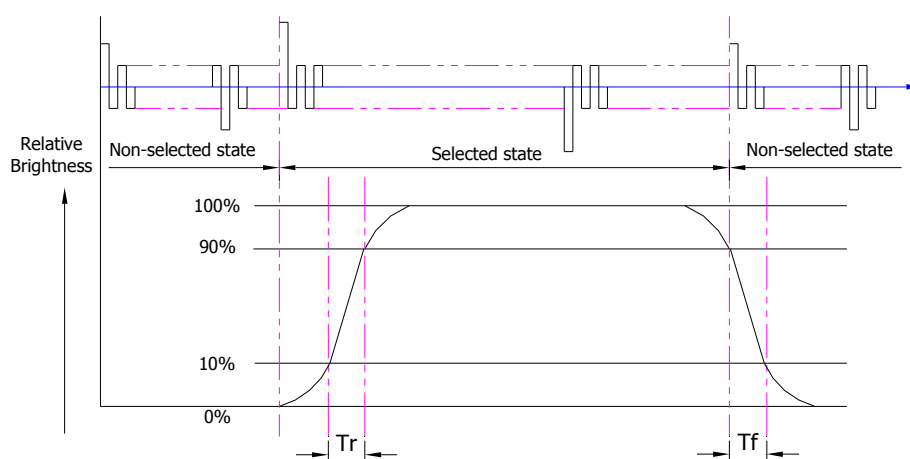

Tr is the time it takes to change from non-selected stage with relative luminance 10% to selected state with relative luminance 90%;

Tf is the time it takes to change from selected state with relative luminance 90% to non-selected state with relative luminance 10%.

Note: Measuring machine: LCD-5100

7.2.2. Normally White Type (Positive)

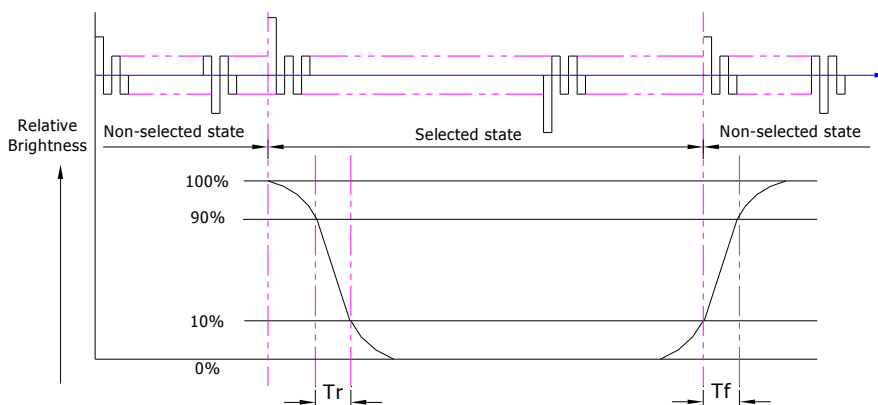

T_r is the time it takes to change from non-selected stage with relative luminance 90% to selected state with relative luminance 10%;

T_f is the time it takes to change from selected state with relative luminance 10% to non-selected state with relative luminance 90%;

Note: Measuring machine: LCD-5100 or EQUI

7.3. Definition of Contrast Ratio

Contrast is measured perpendicular to display surface in reflective and transmissive mode.

The measurement condition is:

Measuring Equipment	Eldim or Equivalent
Measuring Point Diameter	3mm//1mm
Measuring Point Location	Active Area centre point
Test pattern	A: All Pixels white
	B: All Pixel black
Contrast setting	Maximum

Definitions: CR (Contrast) = Luminance of White Pixel / Luminance of Black Pixel

7.4. Definition of Viewing Angles

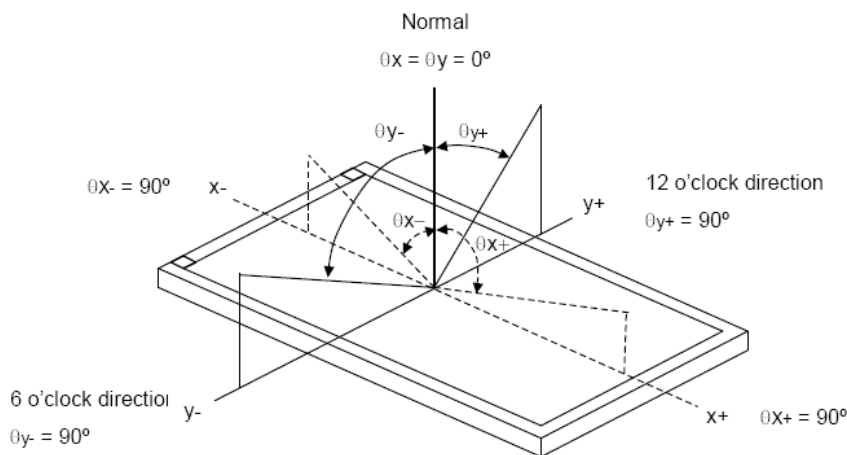

Measuring machine: LCD-5100 or EQUI

7.5. Definition of Color Appearance

R, G, B and W are defined by (x, y) on the IE chromaticity diagram

NTSC=area of RGB triangle/area of NTSC triangleX100%

Measuring picture: Red, Green, Blue and White (Measuring machine: BM-7)

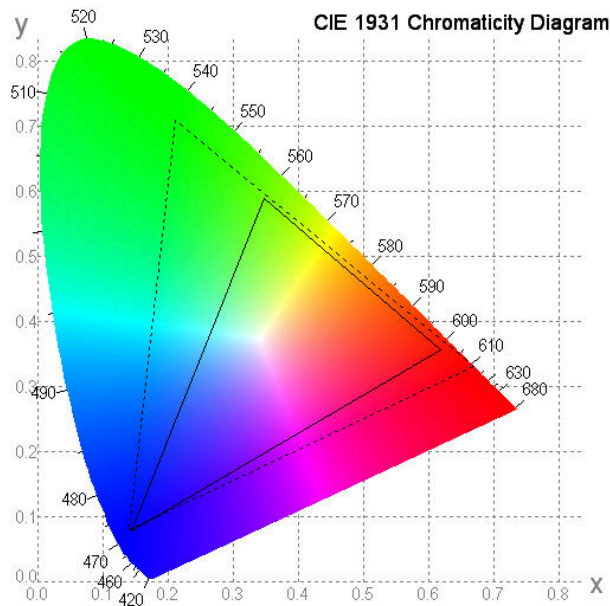

7.6. Definition of Surface Luminance, Uniformity and Transmittance

Using the transmissive mode measurement approach, measure the white screen luminance of the display panel and backlight.

7.6.1. Surface Luminance: $L_V = \text{average}(L_{P1}; L_{P9})$

7.6.2. Uniformity = $\text{Minimal}(L_{P1}; L_{P9}) / \text{Maximal}(L_{P1}; L_{P9}) * 100\%$

7.6.3. Transmittance = $L_V \text{ on LCD} / L_V \text{ on Backlight} * 100\%$

Note: Measuring machine: BM-7

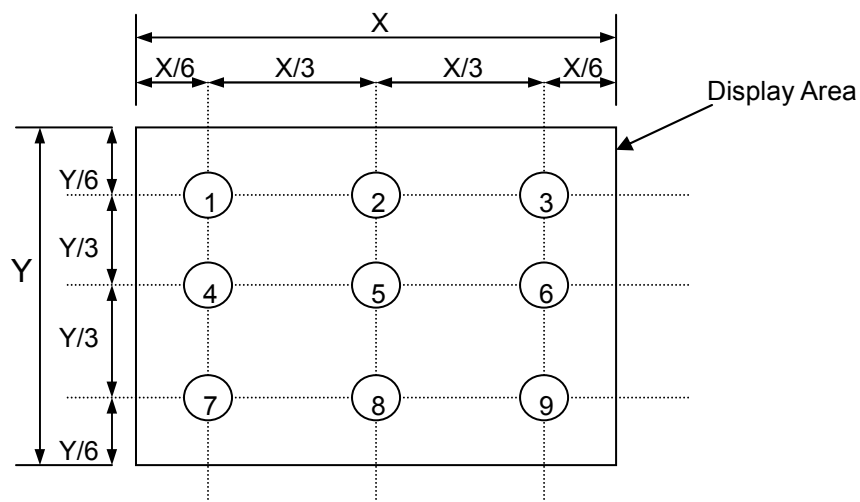

8. Block Diagram and Power Supply

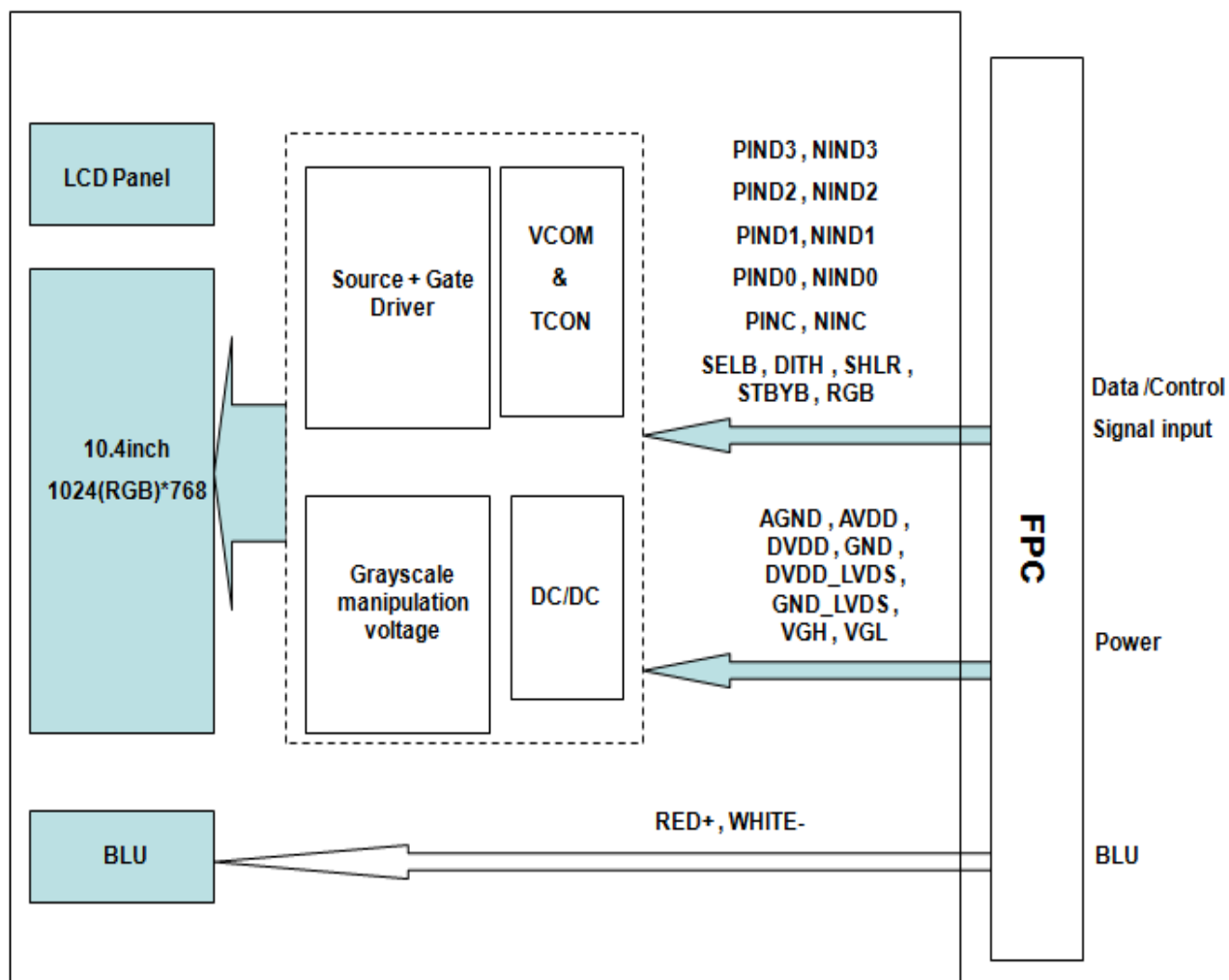

9. Interface Pins Definition

No.	Symbol	Function	Remark
1	AGND	Analog ground	
2	AVDD	Analog power	
3	DVCC	Digital power	
4	GND	Digital ground	
5	VCOM	Not connect	
6	DVDD	Digital power	
7	GND	Digital ground	
8	V14	Not connect	
9	V13	Not connect	
10	V12	Not connect	
11	V11	Not connect	
12	V10	Not connect	
13	V9	Not connect	
14	V8	Not connect	
15	GND	Digital ground	
16	DVDD_LVDS	LVDS power	
17	GND	Digital ground	
18	PIND3	Positive LVDS differential data input	
19	NIND3	Negative LVDS differential data input	
20	GND	Digital ground	
21	PINC	Positive LVDS differential clock input	
22	NINC	Negative LVDS differential clock input	
23	GND	Digital ground	
24	PIND2	Positive LVDS differential data input	
25	NIND2	Negative LVDS differential data input	
26	GND	Digital ground	
27	PIND1	Positive LVDS differential data input	
28	NIND1	Negative LVDS differential data input	
29	GND	Digital ground	
30	PIND0	Positive LVDS differential data input	
31	NIND0	Negative LVDS differential data input	
32	GND	Digital ground	
33	GND_LVDS	LVDS ground	
34	GRB	Global reset pin. Active low to enter reset state. Suggest to connecting with an RC reset circuit for stability. Normally pull high. (R=10K_,C=0.1uF)	
35	STBYB	Standby mode, normally pull high STBYB= 1, normal operation STBYB=0 ,timing control, source driver will turn off, all output are high-Z	
36	SHLR	Left or right display control	NOTE1

37	DVDD	Digital power	
38	UPDN	Up / down display control	NOTE1
39	AGND	Analog ground	
40	AVDD	Analog power	
41	VCOM	Not connect	
42	DITH	Dithering function enable control. Normally pull low DITHER= "1", Enable internal dithering function DITHER= "0", Disable internal dithering function	
43	GND	Digital ground	
44	DVDD	Digital Power	
45	GND	Digital ground	
46	V7	Not connect	
47	V6	Not connect	
48	V5	Not connect	
49	V4	Not connect	
50	V3	Not connect	
51	V2	Not connect	
52	V1	Not connect	
53	GND	Digital ground	
54	DVDD	Digital Power	
55	SELB	6bit/8bit mode select, SELB = "0", LVDS input data is 8bits SELB = "1": LVDS input data is 6bits	NOTE2
56	VGH	Positive power for TFT	
57	DVDD	Digital power for Gate IC	
58	VGL	Negative power for TFT	
59	GND	Digital ground for Gate IC	
60	NC	Not connect	

Note 1 : UPDN and SHLR control function

UPDN	SHLR	Data shifting
0	1	Normally display
0	0	Inverse Left and Right
1	1	Inverse Up and Down
1	0	Inverse Left and Right Inverse Up and Down

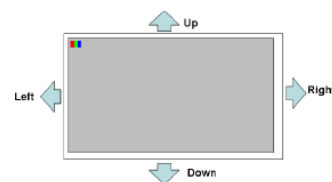
**Note 2 : If LVDS input data is 6 bits, SELB must be set to High**

If LVDS input data is 8 bits, SELB must be set to Low

DITH and SELB control function

DITH	SELB	Data shifting
0	1	Colors (262K)
0	0	Colors (262K)
1	1	Colors (262K)
1	0	Colors (16.2M)

10. AC characteristic

1) Bit LVDS input

6 bit LVDS input

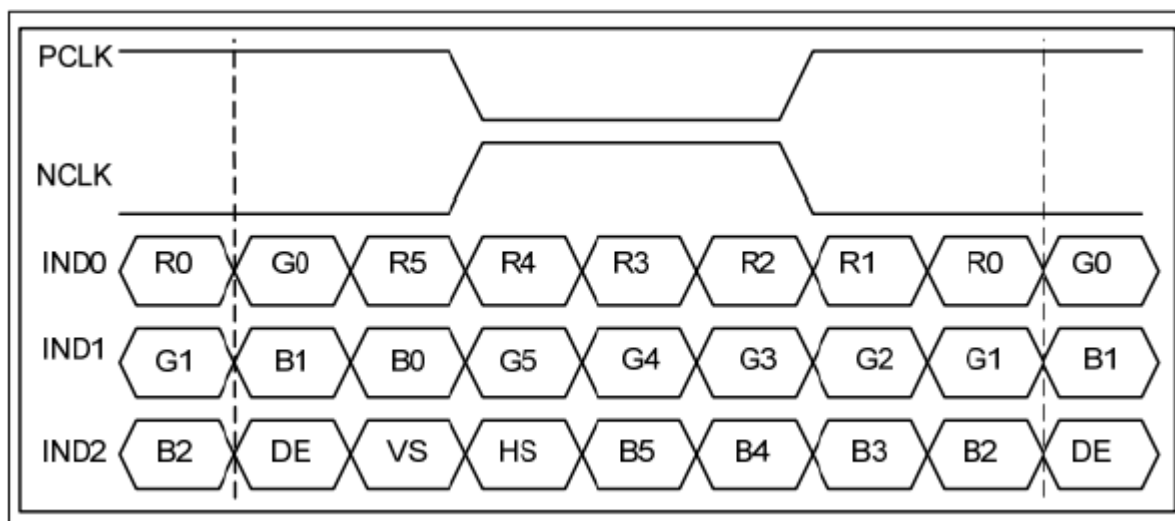

8 bit LVDS input

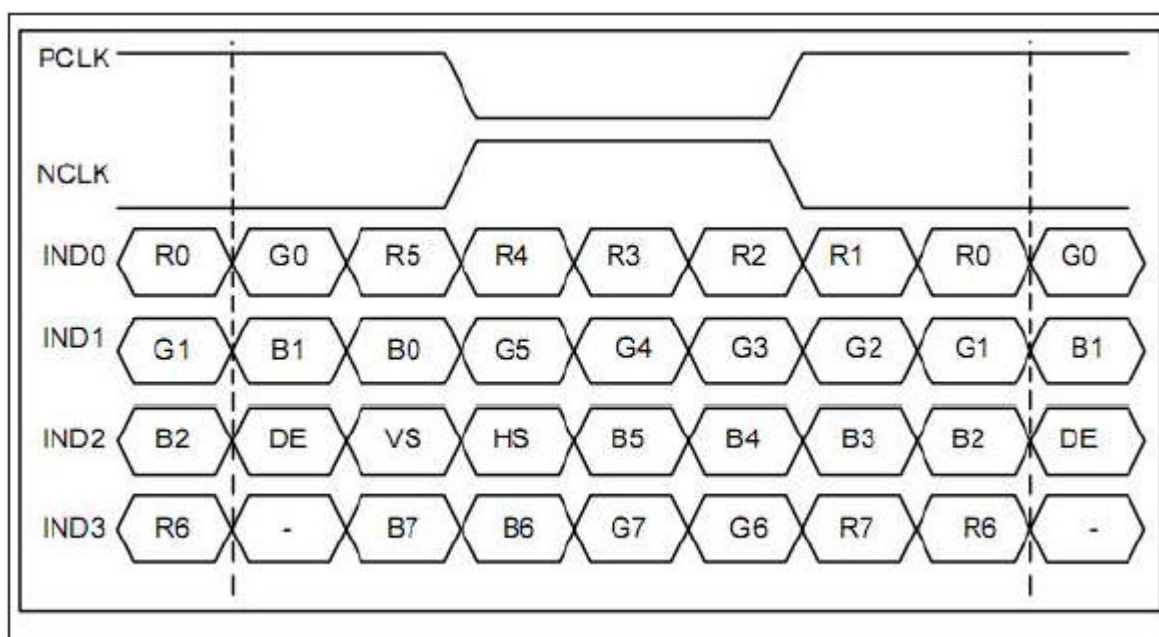

2) Interface Timing (DE mode)

DE mode					
Parameter	Symbol	Value			Unit
		Min.	Typ.	Max.	
DCLK frequency @Frame rate=60hz	fclk	52	65	71	Mhz
Horizontal display area	thd	1024			DCLK
HSYNC period time	th	1114	1344	1400	DCLK
HSYNC blanking	thb+thfp	90	320	376	DCLK
Vertical display area	tvd	768			H
VSYNC period time	tv	778	806	845	H
VSYNC blanking	tvb+tvfp	10	38	77	H

Vertical input timing :

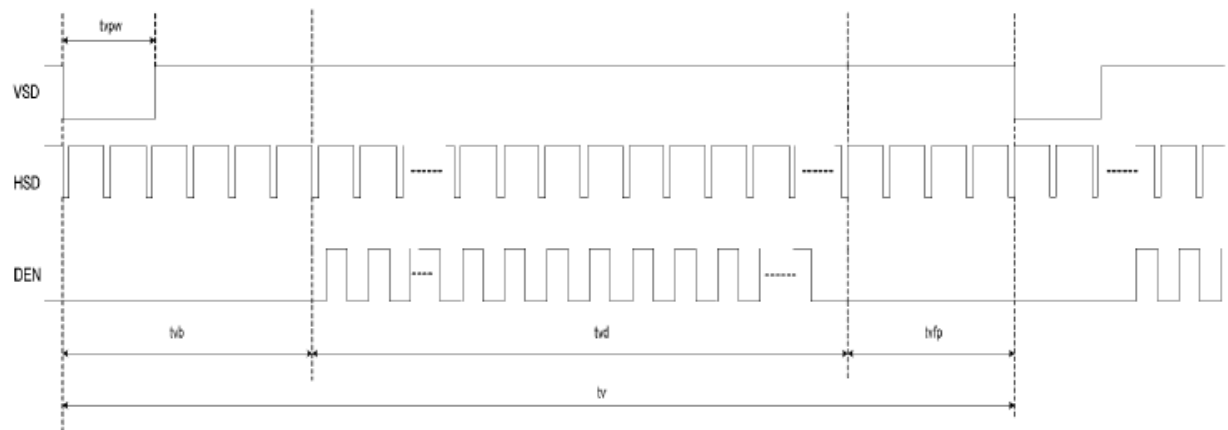

Horizontal input timing :

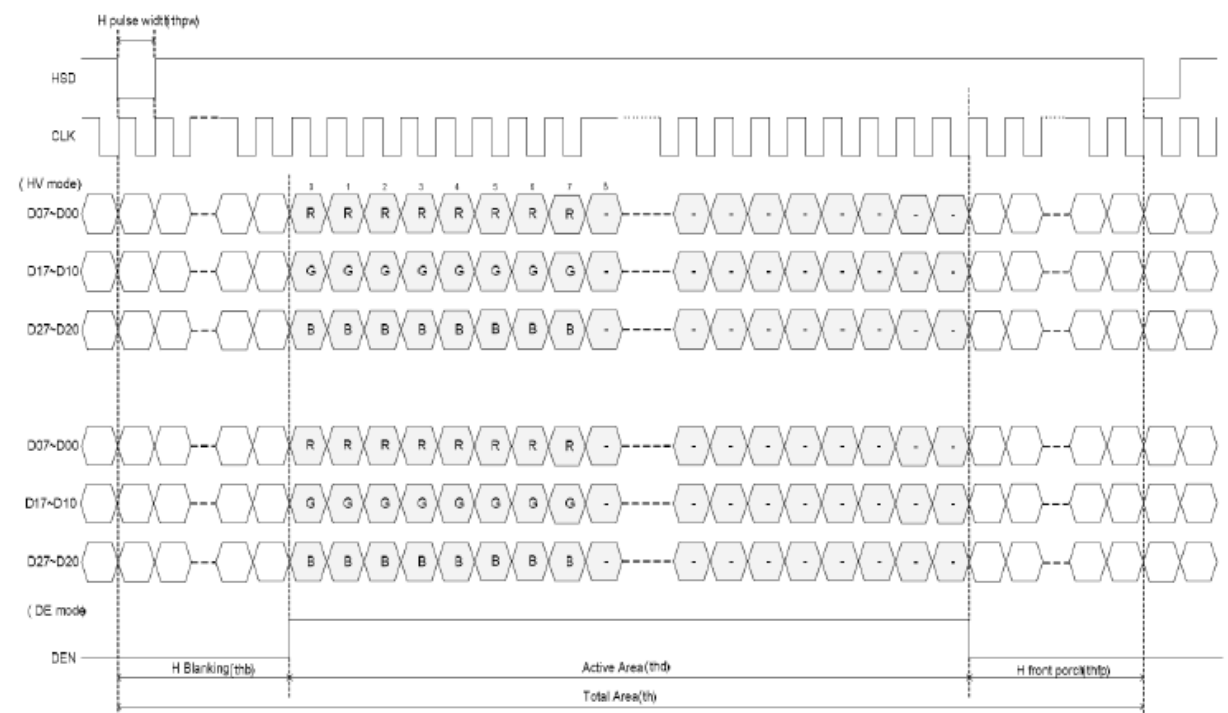

3) Power On / Off Sequence

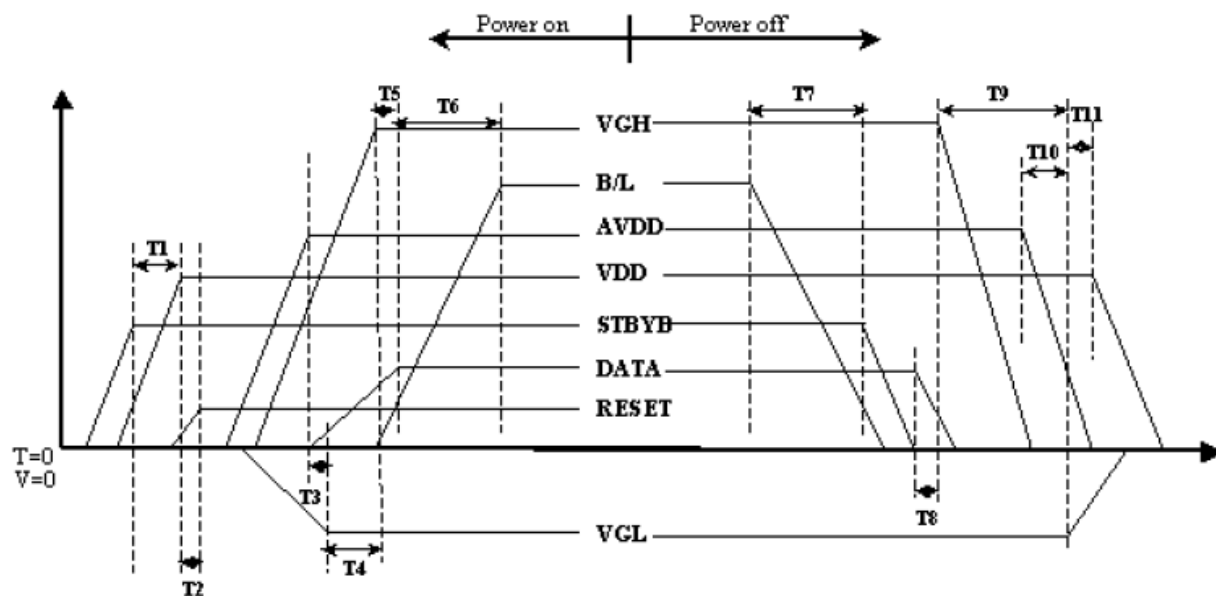

Item	Min.	Typ.	Max.	Unit
T1	0	--	--	ms
T2	50	--	--	ms
T3	5	--	--	ms
T4	10	--	--	ms
T5	20	--	--	ms
T6	50	--	--	ms
T7	20	--	--	ms
T8	10	--	--	ms
T9	20	--	--	ms
T10	10	--	--	ms
T11	20	--	--	ms

11. Quality Assurance

11.1. Purpose

This standard for Quality Assurance assures the quality of LCD module products supplied to customer.

11.2. Standard for Quality Test

11.2.1 Sampling Plan:

GB2828.1-2012

Single sampling, general inspection level II

11.2.2 Sampling Criteria:

Visual inspection: AQL 1.5%

Electrical functional: AQL 0.65%.

11.2.3 Reliability Test:

Detailed requirement refer to Reliability Test Specification.

11.3. Nonconforming Analysis & Disposition

11.3.1 Nonconforming analysis:

11.3.1.1 Customer should provide overall information of non-conforming sample for their complaints.

11.3.1.2 After receipt of detailed information from customer, the analysis of nonconforming parts usually should be finished in one week.

11.3.1.3 If cannot finish the analysis on time, customer will be notified with the progress status.

11.3.2 Disposition of nonconforming:

11.3.2.1 Non-conforming product over PPM level will be replaced.

11.3.2.2 The cause of non-conformance will be analyzed. Corrective action will be discussed and implemented.

11.4. Agreement Items

Shall negotiate with customer if the following situation occurs:

11.4.1 There is any discrepancy in standard of quality assurance.

11.4.2 Additional requirement to be added in product specification.

11.4.3 Any other special problem.

11.5. Standard of the Product Visual Inspection

11.5.1 Appearance inspection:

11.5.1.1 The inspection must be under illumination about 1000 – 1500 lx, and the distance of view must be at 30cm ± 2cm.

11.5.1.2 The viewing angle should be 45° from the vertical line without reflection light or follows customer's viewing angle specifications.

11.5.1.3 Definition of area: A Zone: Active Area, B Zone: Viewing Area,

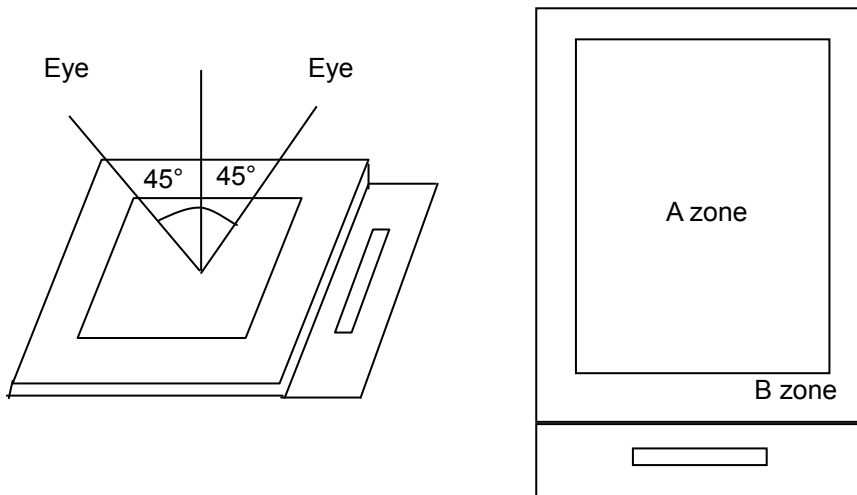

11.5.2 Basic principle:

11.5.2.1 A set of sample to indicate the limit of acceptable quality level must be discussed by both us and customer when there is any dispute happened.

11.5.2.2 New item must be added on time when it is necessary.

11.6. Inspection Specification

No.	Item	Criteria (Unit: mm)																		
01	Black / White spot Foreign material (Round type) Pinholes Stain Particles inside cell. (Minor defect)	<table border="1"> <thead> <tr> <th>Size</th> <th>Area</th> <th>Acc. Qty</th> </tr> </thead> <tbody> <tr> <td>$\phi \leq 0.20$</td> <td></td> <td>Ignore</td> </tr> <tr> <td>$0.20 < \phi \leq 0.50$</td> <td></td> <td>$N \leq 3$</td> </tr> <tr> <td>$0.50 < \phi$</td> <td></td> <td>0</td> </tr> </tbody> </table> <p>$\phi = (a + b) / 2$ Distance between 2 defects should more than 5mm apart.</p>	Size	Area	Acc. Qty	$\phi \leq 0.20$		Ignore	$0.20 < \phi \leq 0.50$		$N \leq 3$	$0.50 < \phi$		0						
Size	Area	Acc. Qty																		
$\phi \leq 0.20$		Ignore																		
$0.20 < \phi \leq 0.50$		$N \leq 3$																		
$0.50 < \phi$		0																		
02	Electrical Defect (Minor defect)	<table border="1"> <thead> <tr> <th>Bright dot</th> <th>Display Area</th> <th>Total</th> <th rowspan="3">Note1</th> </tr> </thead> <tbody> <tr> <td></td> <td>$N \leq 2$</td> <td>$N \leq 2$</td> </tr> <tr> <td>Dark dot</td> <td>$N \leq 4$</td> <td>$N \leq 4$</td> </tr> <tr> <td>Total dot</td> <td>$N \leq 4$</td> <td>$N \leq 4$</td> <td></td> </tr> <tr> <td>Mura</td> <td colspan="2">Not visible through 5% ND filters.</td> <td>Note 2</td> </tr> </tbody> </table> <p>Remark: 1. Bright dot caused by scratch and foreign object accords to item 1.</p>	Bright dot	Display Area	Total	Note1		$N \leq 2$	$N \leq 2$	Dark dot	$N \leq 4$	$N \leq 4$	Total dot	$N \leq 4$	$N \leq 4$		Mura	Not visible through 5% ND filters.		Note 2
Bright dot	Display Area	Total	Note1																	
	$N \leq 2$	$N \leq 2$																		
Dark dot	$N \leq 4$	$N \leq 4$																		
Total dot	$N \leq 4$	$N \leq 4$																		
Mura	Not visible through 5% ND filters.		Note 2																	

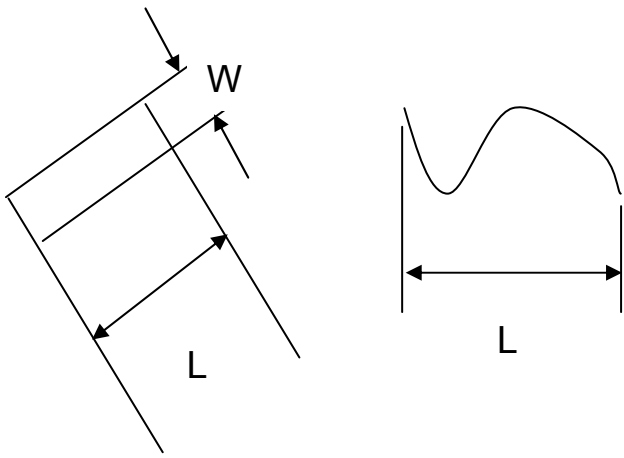
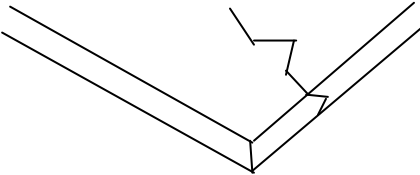
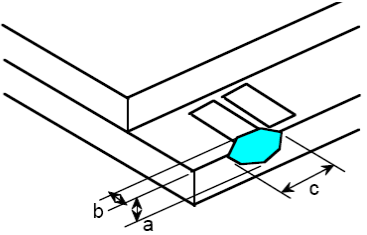
<p>03</p>	<p>Black and White line Scratch Foreign material (Line type) (Minor defect)</p>	 <table border="1" data-bbox="608 745 1235 1010"> <thead> <tr> <th>Length</th> <th>Width</th> <th>Acc Qty</th> </tr> </thead> <tbody> <tr> <td>/</td> <td>$W \leq 0.1$</td> <td>Ignore</td> </tr> <tr> <td>$L \leq 2.5$</td> <td>$0.1 < W \leq 0.2$</td> <td>3</td> </tr> <tr> <td>$L > 2.5$</td> <td>$0.2 < W$</td> <td>0</td> </tr> <tr> <td colspan="2">Total</td> <td>3</td> </tr> </tbody> </table> <p>Distance between 2 defects should more than 3mm apart. Scratches not viewable through the back of the display are acceptable.</p>	Length	Width	Acc Qty	/	$W \leq 0.1$	Ignore	$L \leq 2.5$	$0.1 < W \leq 0.2$	3	$L > 2.5$	$0.2 < W$	0	Total		3
Length	Width	Acc Qty															
/	$W \leq 0.1$	Ignore															
$L \leq 2.5$	$0.1 < W \leq 0.2$	3															
$L > 2.5$	$0.2 < W$	0															
Total		3															
<p>04</p>	<p>Glass Crack (Minor defect)</p>	 <p>Crack is potential to enlarge, any type is not allowed.</p>															
<p>05</p>	<p>Glass Chipping Pad Area: (Minor defect)</p> 	<table border="1" data-bbox="863 1641 1334 1816"> <thead> <tr> <th>Length and Width</th> <th>Acc. Qty</th> </tr> </thead> <tbody> <tr> <td>$c > 3.0, b < 1.0$</td> <td>1</td> </tr> <tr> <td>$c < 3.0, b < 1.0$</td> <td>3</td> </tr> <tr> <td colspan="2">$a < \text{Glass Thickness}$</td> </tr> </tbody> </table>	Length and Width	Acc. Qty	$c > 3.0, b < 1.0$	1	$c < 3.0, b < 1.0$	3	$a < \text{Glass Thickness}$								
Length and Width	Acc. Qty																
$c > 3.0, b < 1.0$	1																
$c < 3.0, b < 1.0$	3																
$a < \text{Glass Thickness}$																	

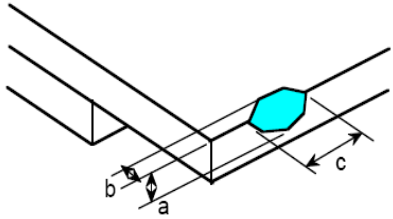
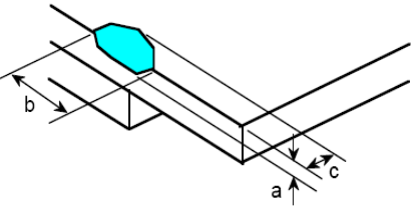
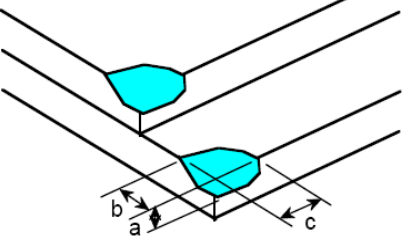
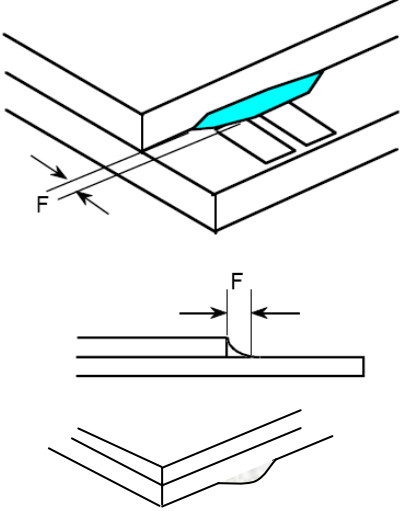
<p>06</p>	<p>Glass Chipping Rear of Pad Area: (Minor defect)</p> 	<table border="1"> <thead> <tr> <th>Length and Width</th> <th>Acc. Qty</th> </tr> </thead> <tbody> <tr> <td>$c > 3.0, b < 1.0$</td> <td>1</td> </tr> <tr> <td>$c < 3.0, b < 1.0$</td> <td>2</td> </tr> <tr> <td>$c < 3.0, b < 0.5$</td> <td>4</td> </tr> <tr> <td colspan="2" style="text-align: center;">$a < \text{Glass Thickness}$</td> </tr> </tbody> </table>	Length and Width	Acc. Qty	$c > 3.0, b < 1.0$	1	$c < 3.0, b < 1.0$	2	$c < 3.0, b < 0.5$	4	$a < \text{Glass Thickness}$	
Length and Width	Acc. Qty											
$c > 3.0, b < 1.0$	1											
$c < 3.0, b < 1.0$	2											
$c < 3.0, b < 0.5$	4											
$a < \text{Glass Thickness}$												
<p>07</p>	<p>Glass Chipping Except Pad Area: (Minor defect)</p> 	<table border="1"> <thead> <tr> <th>Length and Width</th> <th>Acc. Qty</th> </tr> </thead> <tbody> <tr> <td>$c > 3.0, b < 1.0$</td> <td>1</td> </tr> <tr> <td>$c < 3.0, b < 1.0$</td> <td>2</td> </tr> <tr> <td>$c < 3.0, b < 0.5$</td> <td>4</td> </tr> <tr> <td colspan="2" style="text-align: center;">$a < \text{Glass Thickness}$</td> </tr> </tbody> </table>	Length and Width	Acc. Qty	$c > 3.0, b < 1.0$	1	$c < 3.0, b < 1.0$	2	$c < 3.0, b < 0.5$	4	$a < \text{Glass Thickness}$	
Length and Width	Acc. Qty											
$c > 3.0, b < 1.0$	1											
$c < 3.0, b < 1.0$	2											
$c < 3.0, b < 0.5$	4											
$a < \text{Glass Thickness}$												
<p>08</p>	<p>Glass Corner Chipping: (Minor defect)</p> 	<table border="1"> <thead> <tr> <th>Length and Width</th> <th>Acc. Qty</th> </tr> </thead> <tbody> <tr> <td>$c < 3.0, b < 3.0$</td> <td>Ignore</td> </tr> <tr> <td colspan="2" style="text-align: center;">$a < \text{Glass Thickness}$</td> </tr> </tbody> </table>	Length and Width	Acc. Qty	$c < 3.0, b < 3.0$	Ignore	$a < \text{Glass Thickness}$					
Length and Width	Acc. Qty											
$c < 3.0, b < 3.0$	Ignore											
$a < \text{Glass Thickness}$												
<p>09</p>	<p>Glass Burr: (Minor defect)</p> 	<table border="1"> <thead> <tr> <th>Length</th> <th>Acc. Qty</th> </tr> </thead> <tbody> <tr> <td>$F < 1.0$</td> <td>Ignore</td> </tr> </tbody> </table> <p>Glass burr don't affect assemble and module dimension.</p>	Length	Acc. Qty	$F < 1.0$	Ignore						
Length	Acc. Qty											
$F < 1.0$	Ignore											

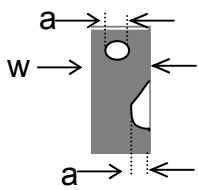
10	<p>FPC Defect: (Minor defect)</p> 	<p>10.1 Dent, pinhole width $a < w/3$. (w: circuitry width.) 10.2 Open circuit is unacceptable. 10.3 No oxidation, contamination and distortion.</p>								
11	<p>Bubble on Polarizer (Minor defect)</p>	<table border="1"> <thead> <tr> <th>Diameter</th> <th>Acc. Qty</th> </tr> </thead> <tbody> <tr> <td>$\varphi \leq 0.30$</td> <td>Ignore</td> </tr> <tr> <td>$0.30 < \varphi \leq 0.50$</td> <td>$N \leq 2$</td> </tr> <tr> <td>$0.50 < \varphi$</td> <td>$N=0$</td> </tr> </tbody> </table>	Diameter	Acc. Qty	$\varphi \leq 0.30$	Ignore	$0.30 < \varphi \leq 0.50$	$N \leq 2$	$0.50 < \varphi$	$N=0$
Diameter	Acc. Qty									
$\varphi \leq 0.30$	Ignore									
$0.30 < \varphi \leq 0.50$	$N \leq 2$									
$0.50 < \varphi$	$N=0$									
12	<p>Dent on Polarizer (Minor defect)</p>	<table border="1"> <thead> <tr> <th>Diameter</th> <th>Acc. Qty</th> </tr> </thead> <tbody> <tr> <td>$\varphi \leq 0.25$</td> <td>Ignore</td> </tr> <tr> <td>$0.25 < \varphi \leq 0.50$</td> <td>$N \leq 4$</td> </tr> <tr> <td>$0.50 < \varphi$</td> <td>None</td> </tr> </tbody> </table>	Diameter	Acc. Qty	$\varphi \leq 0.25$	Ignore	$0.25 < \varphi \leq 0.50$	$N \leq 4$	$0.50 < \varphi$	None
Diameter	Acc. Qty									
$\varphi \leq 0.25$	Ignore									
$0.25 < \varphi \leq 0.50$	$N \leq 4$									
$0.50 < \varphi$	None									
13	<p>Bezel</p>	<p>13.1 No rust, distortion on the Bezel. 13.2 No visible fingerprints, stains or other contamination.</p>								
14	<p>Touch Panel</p>	<p>D: Diameter W: width L: length 14.1 Spot: $D < 0.25$ is acceptable $0.25 \leq D \leq 0.4$ 2dots are acceptable and the distance between defects should more than 10 mm. $D > 0.4$ is unacceptable 14.2 Dent: $D > 0.40$ is unacceptable 14.3 Scratch: $W \leq 0.03$, $L \leq 10$ is acceptable, $0.03 < W \leq 0.10$, $L \leq 10$ is acceptable Distance between 2 defects should more than 10 mm. $W > 0.10$ is unacceptable.</p>								
15	<p>PCB</p>	<p>15.1 No distortion or contamination on PCB terminals. 15.2 All components on PCB must same as documented on the BOM/component layout. 15.3 Follow IPC-A-600F.</p>								
16	<p>Soldering</p>	<p>Follow IPC-A-610C standard</p>								

17	Electrical Defect (Major defect)	<p>The below defects must be rejected.</p> <p>17.1 Missing vertical / horizontal segment, 17.2 Abnormal Display. 17.3 No function or no display. 17.4 Current exceeds product specifications. 17.5 LCD viewing angle defect. 17.6 No Backlight. 17.7 Dark Backlight. 17.8 Touch Panel no function.</p>
----	-------------------------------------	--

Remark: LCD Panel Broken shall be rejected. Defect out of LCD viewing area is acceptable.

11.7. Classification of Defects

11.7.1 Visual defects (Except no / wrong label) are treated as minor defect and electrical defect is major.

11.7.2 Two minor defects are equal to one major in lot sampling inspection.

11.8. Identification/marketing criteria

Any unit with illegible / wrong /double or no marking/ label shall be rejected.

11.9. Packaging

11.9.1 There should be no damage of the outside carton box, each packaging box should have one identical label.

11.9.2 Modules inside package box should have compliant mark.

11.9.3 All direct package materials shall offer ESD protection

Note1: Bright dot is defined as the defective area of the dot is larger than 50% of one sub-pixel area.

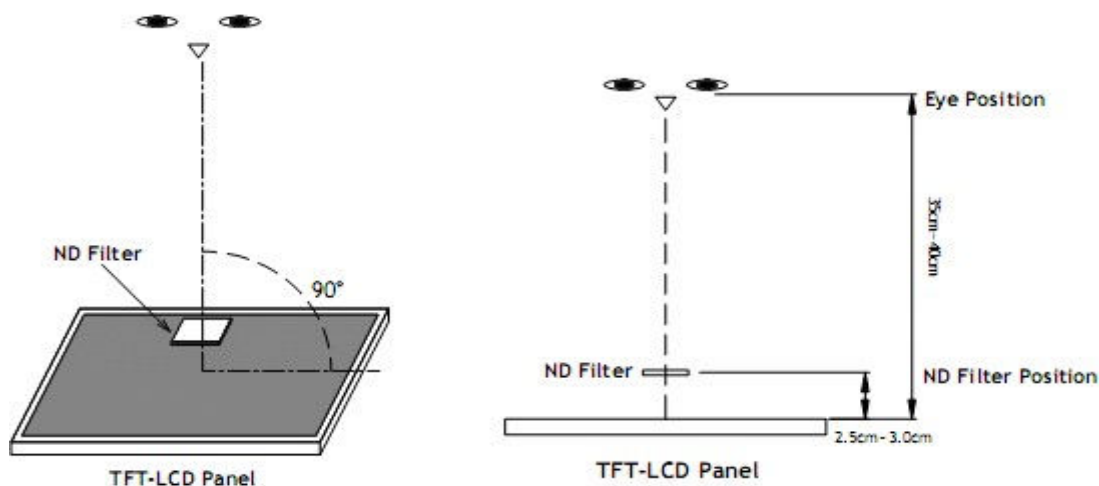

Bright dot: The bright dot size defect at black display pattern. It can be recognized by 2% transparency of filter when the distance between eyes and panel is $350\text{mm} \pm 50\text{mm}$.

Dark dot: Cyan, Magenta or Yellow dot size defect at white display pattern. It can be recognized by 5% transparency of filter when the distance between eyes and panel is $350\text{mm} \pm 50\text{mm}$.

Note2: Mura on display which appears darker / brighter against background brightness on parts of display area.

12. Reliability Specification

No	Item	Condition	Quantity	Criteria
1	High Temperature Operating	70°C, 96Hrs	2	GB/T2423.2-2008
2	Low Temperature Operating	-20°C, 96Hrs	2	GB/T2423.1-2008
3	High Humidity	50°C, 90%RH, 96Hrs	2	GB/T2423.3-2006
4	High Temperature Storage	80°C, 96Hrs	2	GB/T2423.2-2008
5	Low Temperature Storage	-30°C, 96Hrs	2	GB/T2423.1-2008
6	Thermal Cycling Test	-20°C, 60min~70°C, 60min, 20 cycles.	2	GB/T2423.22-2012
7	Packing vibration	Frequency range:10Hz~50Hz Acceleration of gravity:5G X, Y, Z 30 min for each direction.	2	GB/T5170.14-2009
8	Electrical Static Discharge	Air: ±4KV 150pF/330 Ω 5 times Contact: ±2KV 150pF/330 Ω 5 times	2	GB/T17626.2-2006
9	Drop Test (Packaged)	Height:80 cm,1 corner, 3 edges, 6 surfaces.	2	GB/T2423.8-1995

Note1. No deflection cosmetic and operational function allowable.

Note2. Total current Consumption should be below double of initial value

13. Precautions and Warranty

13.1. Safety

- 13.1.1. The liquid crystal in the LCD is poisonous. Do not put it in your mouth. If the liquid crystal touches your skin or clothes, wash it off immediately using soap and water.
- 13.1.2. Since the liquid crystal cells are made of glass, do not apply strong impact on them. Handle with care.

13.2. Handling

- 13.2.1. Reverse and use within ratings in order to keep performance and prevent damage.
- 13.2.2. Do not wipe the polarizer with dry cloth, as it might cause scratch. If the surface of the LCD needs to be cleaned, wipe it swiftly with cotton or other soft cloth soaked with petroleum IPA, do not use other chemicals.

13.3. Storage

- 13.3.1. Do not store the LCD module beyond the specified temperature ranges.
- 13.3.2. Strong light exposure causes degradation of polarizer and color filter

13.4. Metal Pin (Apply to Products with Metal Pins)

- 13.4.1. Pins of LCD and Backlight
 - 13.4.1.1. Solder tip can touch and press on the tip of Pin LEAD during the soldering
 - 13.4.1.2. Recommended Soldering Conditions
 - Solder Type: Sn96.3~94-Ag3.3~4.3-Cu0.4~1.1
 - Maximum Solder Temperature: 370℃
 - Maximum Solder Time: 3s at the maximum temperature
 - Recommended Soldering Temp: 350±20℃
 - Typical Soldering Time: ≤3s

13.4.1.3. Solder Wetting

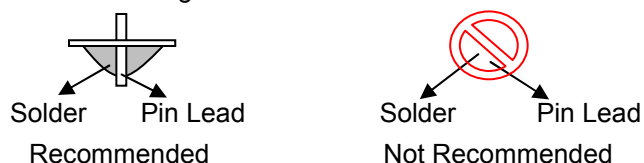

- 13.4.2. Pins of EL
 - 13.4.2.1. Solder tip can touch and press on the tip of EL leads during soldering.
 - 13.4.2.2. No Solder Paste on the soldering pad on the motherboard is recommended.
 - 13.4.2.3. Recommended Soldering Conditions
 - Solder type: Nippon Alimit Leadfree SR-34, size 0.5mm
 - Recommended Solder Temperature: 270~290℃
 - Typical Soldering Time: ≤2s
 - Minimum solder distance from EL lamp (body):2.0mm
 - 13.4.2.4. No horizontal press on the EL leads during soldering.
 - 13.4.2.5. 180° bend EL leads three times is not allowed.

13.4.2.6. Solder Wetting

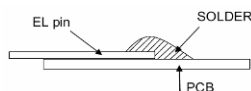

Recommended



Not Recommended

13.4.2.7. The type of the solder iron:

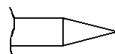

Recommended

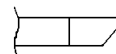

Not Recommended

13.4.2.8. Solder Pad

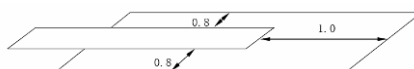
**13.5. Operation**

- 13.5.1. Do not drive LCD with DC voltage
- 13.5.2. Response time will increase below lower temperature
- 13.5.3. Display may change color with different temperature
- 13.5.4. Mechanical disturbance during operation, such as pressing on the display area, may cause the segments to appear "fractured".
- 13.5.5. Do not connect or disconnect the LCM to or from the system when power is on.
- 13.5.6. Never use the LCM under abnormal condition of high temperature & high humidity.
- 13.5.7. Module has high frequency circuits. Sufficient suppression to the electromagnetic interface shall be done by system manufacturers. Grounding and shielding methods may be important to minimize the interference.
- 13.5.8. Do not display the fixed pattern for long time (we suggest the time not longer than one hour) because it may develop image sticking due to the TFT structure.

13.6. Static Electricity

- 13.6.1. CMOS LSIs are equipped in this unit, so care must be taken to avoid the electro-static charge, by ground human body, etc.
- 13.6.2. The normal static prevention measures should be observed for work clothes and benches.
- 13.6.3. The module should be kept into anti-static bags or other containers resistant to static for storage.

13.7. Limited Warranty

- 13.7.1. Our warranty liability is limited to repair and/or replacement. We will not be responsible for any consequential loss.
- 13.7.2. If possible, we suggest customer to use up all modules in six months. If the module storage time over twelve months, we suggest that recheck it before the module be used.
- 13.7.3. After the product shipped, any product quality issues must be feedback within three months, otherwise, we will not be responsible for the subsequent or consequential events.

14. Packaging

TBD

QP-001-027

25/25

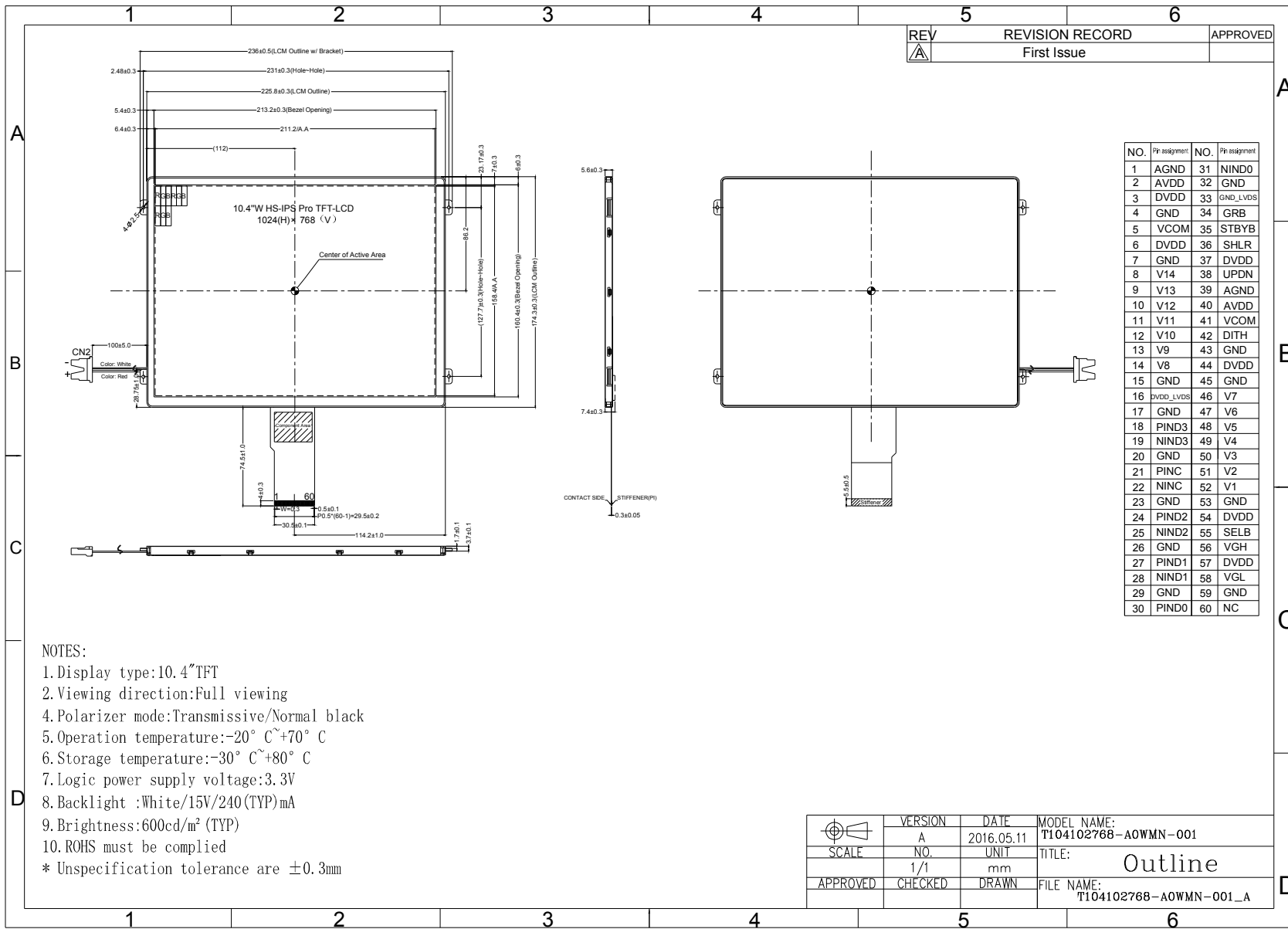

NOTES:

1. Display type:10.4\"/>TFT
 2. Viewing direction:Full viewing
 4. Polarizer mode:Transmissive/Normal black
 5. Operation temperature:-20° C~+70° C
 6. Storage temperature:-30° C~+80° C
 7. Logic power supply voltage:3.3V
 8. Backlight :White/15V/240(TYP)mA
 9. Brightness:600cd/m² (TYP)
 10. ROHS must be complied
- * Unspecification tolerance are ±0.3mm

REV	REVISION RECORD	APPROVED
A	First Issue	

NO.	Pri assignment	NO.	Pri assignment
1	AGND	31	NIND0
2	AVDD	32	GND
3	DVDD	33	GND_LVDS
4	GND	34	GRB
5	VCOM	35	STBYB
6	DVDD	36	SHLR
7	GND	37	DVDD
8	V14	38	UPDN
9	V13	39	AGND
10	V12	40	AVDD
11	V11	41	VCOM
12	V10	42	DITH
13	V9	43	GND
14	V8	44	DVDD
15	GND	45	GND
16	DVDD_LVDS	46	V7
17	GND	47	V6
18	PIND3	48	V5
19	NIND3	49	V4
20	GND	50	V3
21	PINC	51	V2
22	NINC	52	V1
23	GND	53	GND
24	PIND2	54	DVDD
25	NIND2	55	SELB
26	GND	56	VGH
27	PIND1	57	DVDD
28	NIND1	58	VGL
29	GND	59	GND
30	PIND0	60	NC

	VERSION	DATE	MODEL NAME:
	A	2016.05.11	T104102768-AOWMN-001
SCALE	NO.	UNIT	TITLE:
	1/1	mm	Outline
APPROVED	CHECKED	DRAWN	FILE NAME:
			T104102768-AOWMN-001_A

15. Outline Drawing

T104102768-AOWMN-001
Rev:1.1