

PRODUCT SPECIFICATION

5.0" TN TFT LCD MODULE

MODEL: T050800480-A3TMR-002 Ver:1.8



< ◇ > Preliminary Specification

< ◆ > Finally Specification

CUSTOMER'S APPROVAL	
CUSTOMER :	
SIGNATURE:	DATE:

APPROVED BY	PM REVIEWED	PD REVIEWED	PREPARED BY

Revision History

Revision	Date	Originator	Detail	Remarks
1.0	2013.11.26		Initial Release	
1.1	2014.01.17		Add Weight Add Touch Screen Panel Specifications Modify Chromaticity Transmissive	P4 P6 P7
1.2	2014.03.26		Add current Modify CLKIN Pin Definition Modify Inspection Specification Modify Reliability Specification	P5 P11 P20 P25
1.3	2014.09.29		Modify Data Input Format Modify Inspection Specification	P12,13,14 P20
1.4	2015.07.30	TQ	Modify Chromaticity Transmissive Modify Standard for Quality Test	P7 P16
1.5	2015.12.09	TQ	Modify Chromaticity Transmissive	P7
1.6	2016.06.17	ZFY	Modify IC (External Gamma enable) Modify Timing Characteristics	P14
1.7	2016.10.28	ZFY	Modify current	P5
1.8	2018.04.26	ZFY	Modify driver IC Add LED working life Modify many details	P4/P12/P13 P5 P6/P21/P22

Table of Contents

No.	Item	Page
1.	General Description.....	4
2.	Module Parameter.....	4
3.	Absolute Maximum Ratings.....	4
4.	DC Characteristics	5
5.	Backlight Characteristic.....	5
5.1.	Backlight Characteristics	5
5.2.	Backlighting circuit.....	5
6.	Touch Screen Panel Specifications	6
7.	Optical Characteristics	7
7.1.	Optical Characteristics	7
7.2.	Definition of Response Time	7
7.3.	Definition of Contrast Ratio	8
7.4.	Definition of Viewing Angles	8
7.5.	Definition of Color Appearance.....	9
7.6.	Definition of Surface Luminance, Uniformity and Transmittance	9
8.	Block Diagram and Power Supply.....	10
9.	Interface Pins Definition	11
10.	Timing Chart.....	12
10.1.	Parallel 24-bit RGB mode.....	12
10.2.	Input Clock and Data Timing Diagram.....	12
10.3.	Data Input Format.....	13
11.	Quality Assurance	14
11.1.	Purpose	14
11.2.	Standard for Quality Test	14
11.3.	Nonconforming Analysis & Disposition.....	14
11.4.	Agreement Items	14
11.5.	Standard of the Product Visual Inspection	14
11.6.	Inspection Specification.....	15
11.7.	Classification of Defects	19
11.8.	Identification/marketing criteria.....	19
11.9.	Packaging.....	19
12.	Reliability Specification.....	20
13.	Precautions and Warranty.....	21
13.1.	Safety	21
13.2.	Handling	21
13.3.	Storage	21
13.4.	Metal Pin (Apply to Products with Metal Pins).....	21
13.5.	Operation.....	22
13.6.	Static Electricity	22
13.7.	Limited Warranty	22
14.	Packaging.....	23
15.	Outline Drawing.....	24

1. General Description

The specification is a transmissive type color active matrix liquid crystal display (LCD) which uses amorphous thin film transistor (TFT) as switching devices. This product is composed of a TFT-LCD panel, driver Ics, a touch panel and a backlight unit.

2. Module Parameter

Features	Details	Unit
Display Size(Diagonal)	5.0"	
LCD type	TN TFT	
Display Mode	Normally White/Transmissive	
Resolution	800 RGB x 480	Pixels
View Direction	12 O'clock	Best Image
Gray Scale Inversion Direction	6 O'clock	
Module Outline	120.7 (H) x 75.8 (V) x 4.3(T) (Note 1)	mm
Active Area	108 (H) x 64.8(V)	mm
Pixel Size	135 (H) x 135(V)	um
Pixel Arrangement	R.G.B Vertical Stripe	
Polarizer Surface Treatment	Anti-Glare	
Display Colors	16.7M	
Drive IC	ILI6126C & ILI5960D	
Interface	24-bit RGB interface	
With or Without Touch Panel	With	
Operating Temperature	-20~70	°C
Storage Temperature	-30~80	°C
Weight	83	g

Note 1: Exclusive hooks, posts, FFC/FPC tail etc.

3. Absolute Maximum Ratings

$V_{SS}=0V, T_a=25^{\circ}C$

Item	Symbol	Min.	Max.	Unit
Supply Voltage	VDD	-0.5	5.0	V
Storage temperature	T_{STG}	-30	+80	°C
Operating temperature	T_{OP}	-20	+70	°C

Note 1: If T_a below $50^{\circ}C$, the maximal humidity is 90%RH, if T_a over $50^{\circ}C$, absolute humidity should be less than 60%RH.

Note 2: The response time will be extremely slow when the operating temperature is around $-10^{\circ}C$, and the back ground will become darker at high temperature operating.

4. DC Characteristics

Item	Symbol	Min.	Typ.	Max.	Unit	
Supply Voltage	VDD	3.0	3.3	3.6	V	
Logic Low input voltage	V_{IL}	0	-	0.3*VDD	V	
Logic High input voltage	V_{IH}	0.7*VDD	-	VDD	V	
Logic Low output voltage	V_{OL}	-	-	VSS+0.4	V	
Logic High output voltage	V_{OH}	VDD-0.4	-	-	V	
Current Consumption All Black	Logic	$I_{CC+I_{IN}}$	-	110	200	mA
	Analog					

5. Backlight Characteristic

5.1. Backlight Characteristics

Item	Symbol	Condition	Min.	Typ.	Max.	Unit
Backlight Voltage	V_{LED}	$T_a=25\text{ }^\circ\text{C}$, $I_F=20\text{mA/LED}$	19.6	22.4	23.8	V
Backlight Current	I_{LED}	$T_a=25\text{ }^\circ\text{C}$, $V_F=3.2\text{V/LED}$	30	40	50	mA
Power dissipation	P_D		588	896	1190	mW
Uniformity	Avg		75	80	-	%
LED working life($25\text{ }^\circ\text{C}$)	-		20,000	30,000	-	Hrs
Drive method	Constant current					
LED Configuration	14 White LEDs(7 LEDs in one string and 2 groups in parallel)					

5.2. Backlighting circuit

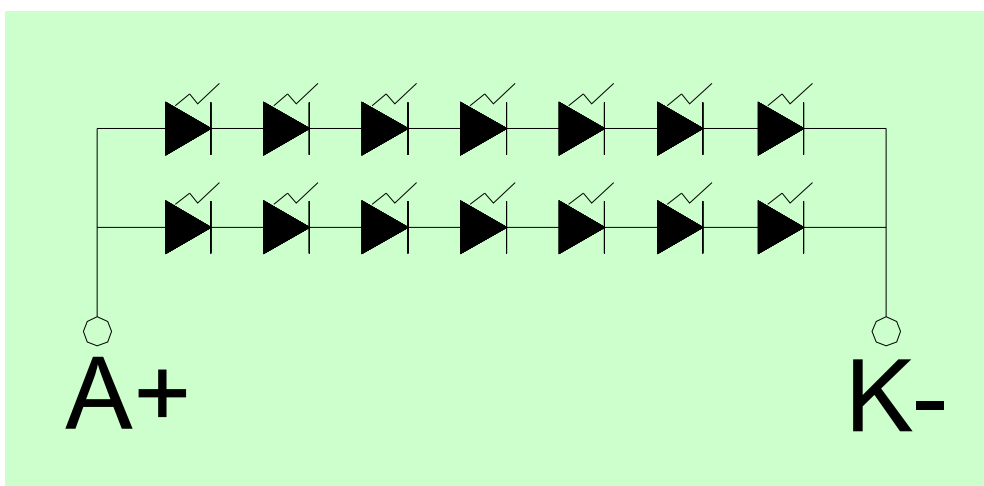

6. Touch Screen Panel Specifications

6.1 Electrical Characteristics

Item	Min.	Typ.	Max.	Unit	Note
Linearity	-1.5	-	1.5	%	Analog X and Y directions
Terminal resistance	350	-	1000	Ω	X (Film side)
	100	-	450	Ω	Y (Glass side)
Insulation resistance	20	-	-	M Ω	DC \leq 10V
Voltage	-	-	10	V	DC
Chattering	-	-	10	ms	

Caution (1) : Do not operate it with a thing except a polyacetal pen (tip R0.8mm or less) or a finger nail, especially those with hard or sharp tips such as a ball point pen or a mechanical pencil.

Caution (2) : RTP operation must be followed the parameter condition.

Caution (3) : If ask for use glare ITO film , it's will has newton issue

6.2 Mechanical & Reliability Characteristics

Item	Min.	Typ.	Max.	Unit	Note
Activation force	20	-	100	g	(1)
Durability-surface scratching	Write 20,000	-	-	characters	(2)
Durability-surface pitting	1,000,000	-	-	touches	(3)
Surface hardness	3	-	-	H	

Note (1) Stylus pen Input R0.8mm polyacetal pen or Finger nail

Note (2) Measurement for Surface area

- Force: 150-250gf
- Speed: 60mm/sec
- Stylus: R0.8 polyacetal pen or Finger nail

Note (3) Pit 1,000,000 times on the Film with a R3.75 silicon rubber.

- Force: Force: 2.45N
- Speed: 3times/sec

7. Optical Characteristics

7.1. Optical Characteristics

$T_a=25^{\circ}\text{C}$, $V_{DD}=3.3\text{V}$

	Item	Symbol	Condition	Specification			Unit	
				Min.	Typ.	Max.		
Backlight On (Transmissive Mode)	Luminance on TFT($I_f=20\text{mA/LED}$)	Lv	Normally viewing angle $\theta_x = \phi_y = 0^{\circ}$	190	240	-	cd/m ²	
	Contrast ratio(See 7.3)	CR		-	350	-		
	Response time (See 7.2)	T_R+T_F		-	20	-	ms	
	Chromaticity Transmissive (See 7.5)	Red	X _R	Center CR ≥ 10	0.556	0.606	0.656	
			Y _R		0.315	0.365	0.415	
		Green	X _G		0.275	0.325	0.375	
			Y _G		0.564	0.614	0.664	
		Blue	X _B		0.099	0.149	0.199	
			Y _B		0.056	0.106	0.156	
	White	X _W	0.230	0.280	0.330			
Y _W		0.275	0.325	0.375				
Viewing Angle (See 7.4)	Horizontal	θ_{x+}	Center CR ≥ 10	60	70	-	Deg.	
		θ_{x-}		60	70	-		
	Vertical	ϕ_{y+}		45	50	-		
		ϕ_{y-}		60	70	-		
NTSC Ratio(Gamut)				-	50	-	%	

7.2. Definition of Response Time

7.2.1. Normally Black Type (Negative)

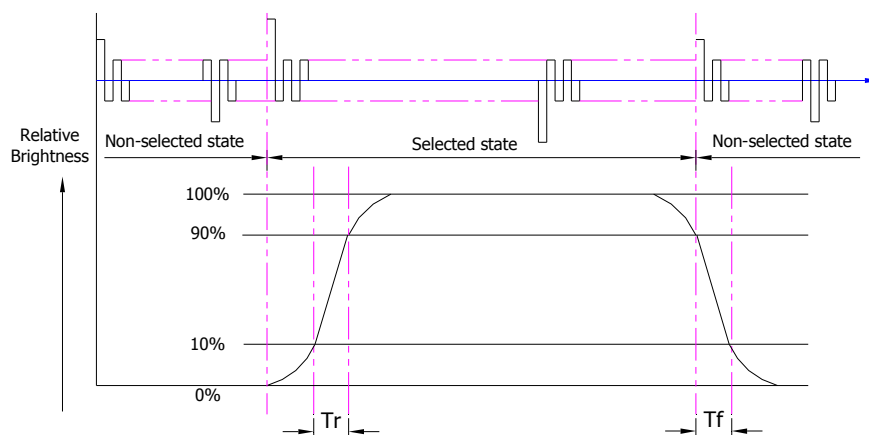

T_r is the time it takes to change from non-selected stage with relative luminance 10% to selected state with relative luminance 90%;

T_f is the time it takes to change from selected state with relative luminance 90% to

non-selected state with relative luminance 10%

Note : Measuring machine: LCD-5100

7.2.2. Normally White Type (Positive)

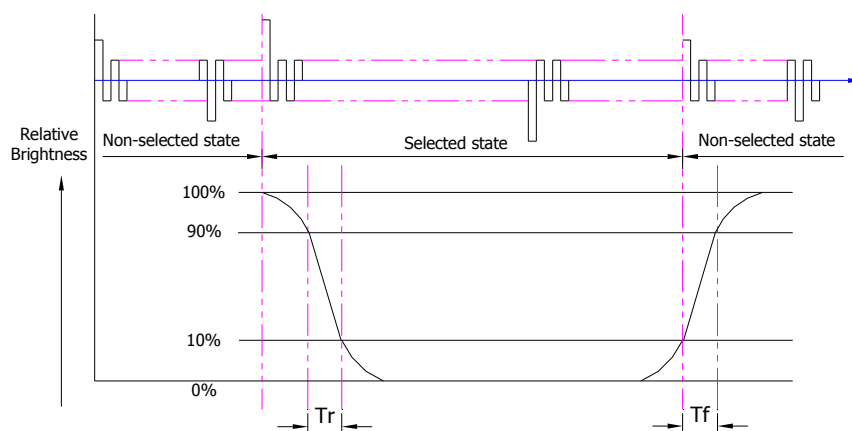

Tr is the time it takes to change from non-selected state with relative luminance 90% to selected state with relative luminance 10%;

Tf is the time it takes to change from selected state with relative luminance 10% to non-selected state with relative luminance 90%;

Note : Measuring machine: LCD-5100 or EQUI

7.3. Definition of Contrast Ratio

Contrast is measured perpendicular to display surface in reflective and transmissive mode.

The measurement condition is:

Measuring Equipment	Eldim or Equivalent
Measuring Point Diameter	3mm//1mm
Measuring Point Location	Active Area centre point
Test pattern	A: All Pixels white
	B: All Pixel black
Contrast setting	Maximum

Definitions: CR (Contrast) = Luminance of White Pixel / Luminance of Black Pixel

7.4. Definition of Viewing Angles

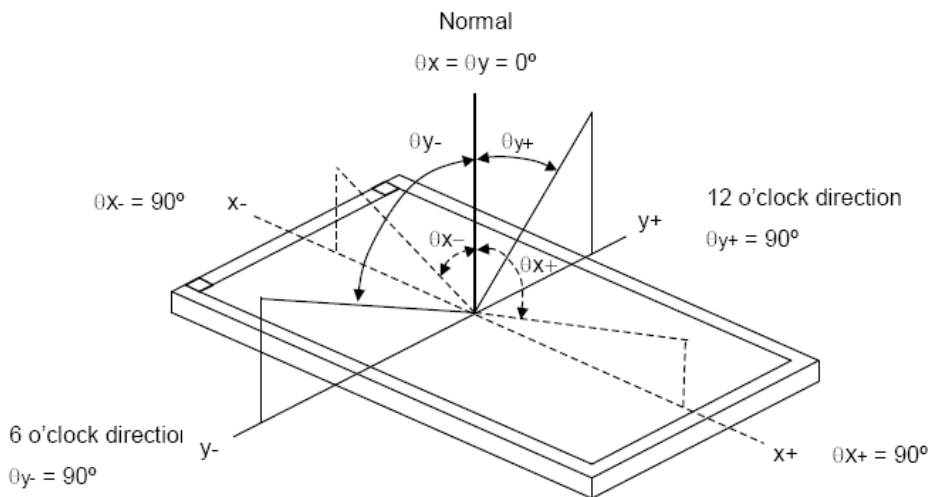

Measuring machine: LCD-5100 or EQUI

7.5. Definition of Color Appearance

R,G,B and W are defined by (x, y) on the IE chromaticity diagram

NTSC=area of RGB triangle/area of NTSC triangleX100%

Measuring picture: Red, Green, Blue and White (Measuring machine: BM-7)

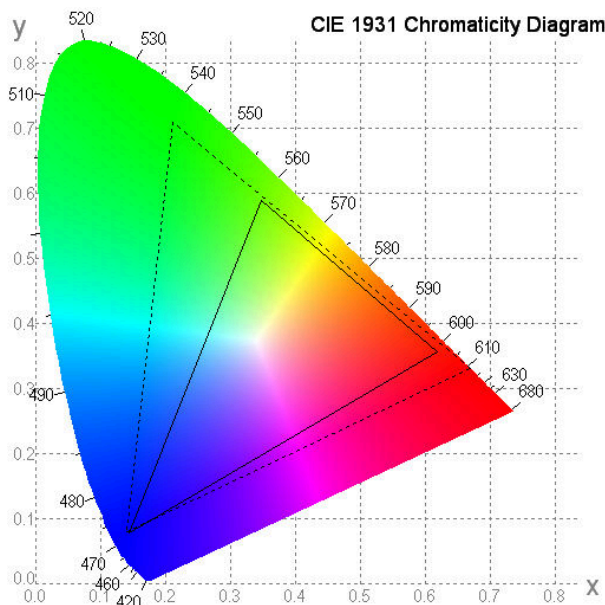

7.6. Definition of Surface Luminance, Uniformity and Transmittance

Using the transmissive mode measurement approach, measure the white screen luminance of the display panel and backlight.

7.6.1. Surface Luminance: $L_V = \text{average} (L_{P1}:L_{P9})$

7.6.2. Uniformity = Minimal ($L_{P1}:L_{P9}$) / Maximal ($L_{P1}:L_{P9}$) * 100%

7.6.3. Transmittance = L_V on LCD / L_V on Backlight * 100%

Note: Measuring machine: BM-7

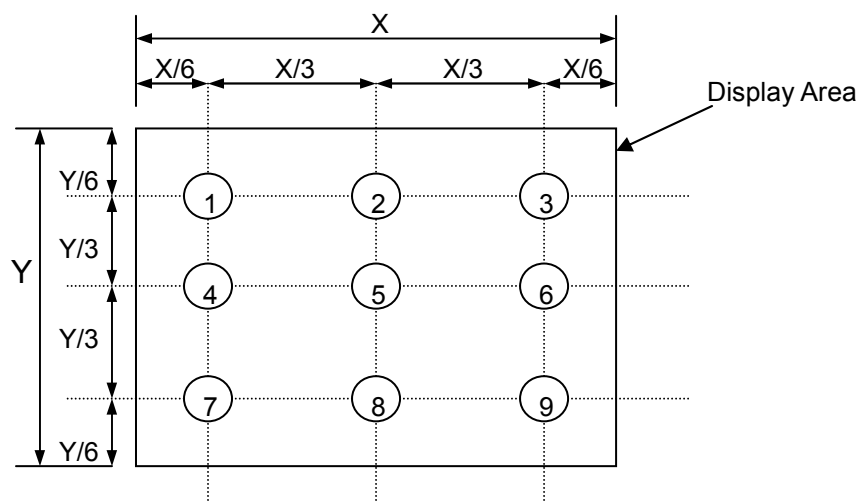

8. Block Diagram and Power Supply

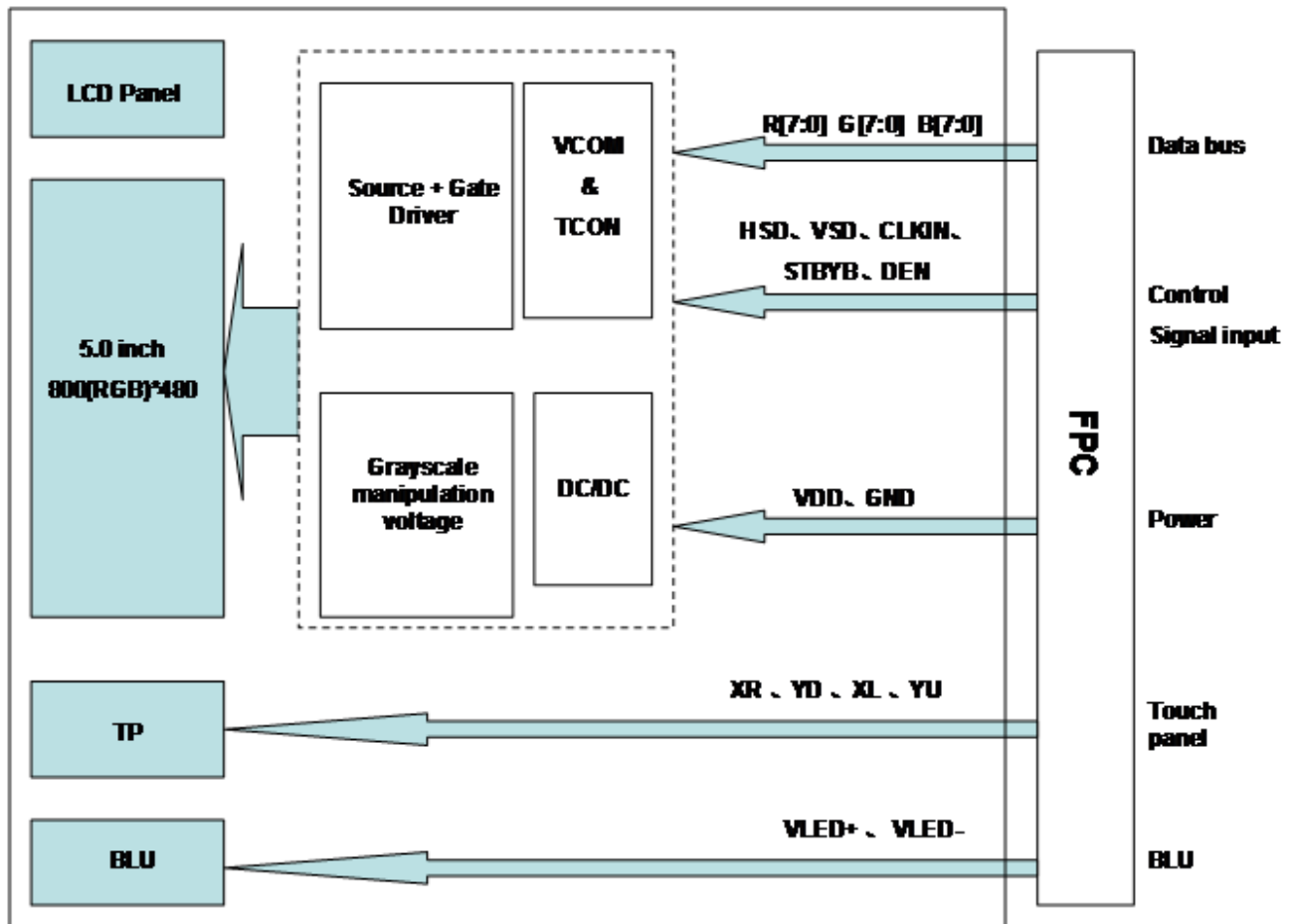

9. Interface Pins Definition

No.	Symbol	Function	Remark
1	VLED-	Ground (Cathode).	
2	VLED+	LED Input Terminal (Anode).	
3	GND	Ground.	
4	VDD	Power voltage.	
5	R0	Red data (LSB).	
6	R1	Red data.	
7	R2	Red data.	
8	R3	Red data.	
9	R4	Red data.	
10	R5	Red data.	
11	R6	Red data.	
12	R7	Red data (MSB).	
13	G0	Green data (LSB).	
14	G1	Green data.	
15	G2	Green data.	
16	G3	Green data.	
17	G4	Green data.	
18	G5	Green data.	
19	G6	Green data.	
20	G7	Green data (MSB).	
21	B0	Blue data (LSB).	
22	B1	Blue data.	
23	B2	Blue data.	
24	B3	Blue data.	
25	B4	Blue data.	
26	B5	Blue data.	
27	B6	Blue data.	
28	B7	Blue data (MSB).	
29	GND	Ground.	
30	CLKIN	Clock for input data. Data latched at falling edge of this signal.	
31	STBYB	Display on/off.	
32	HSD	Horizontal sync signal.	
33	VSD	Vertical sync signal.	
34	DEN	Data enable.	
35	NC	No connection.	
36	GND	Ground.	
37	XR	Touch panel terminal.	
38	YD	Touch panel terminal.	
39	XL	Touch panel terminal.	
40	YU	Touch panel terminal.	

10. Timing Chart

10.1.Parallel 24-bit RGB mode

Parameter	Symbol	Min.	Typ.	Max.	Unit	Conditions
CLKIN Frequency	Fclk	-	33	50	MHz	VDD = 2.7V ~3.6V
CLKIN Cycle Time	Tclk	20	30	-	ns	
CLKIN Pulse Duty	Tcwh	40	50	60	%	Tclk
Time from HSD to Source Output	Thso	-	64	-	CLKIN	
Time from HSD to LD	Thld	-	64	-	CLKIN	
Time from HSD to STV	Thstv	-	2	-	CLKIN	
Time from HSD to CKV	Thckv	-	20	-	CLKIN	
Time from HSD to OEV	Thoev	-	4	-	CLKIN	
LD Pulse Width	Twd	-	10	-	CLKIN	
CKV Pulse Width	Twckv	-	66	-	CLKIN	
OEV Pulse Width	Twoev	-	92	-	CLKIN	

10.2.Input Clock and Data Timing Diagram

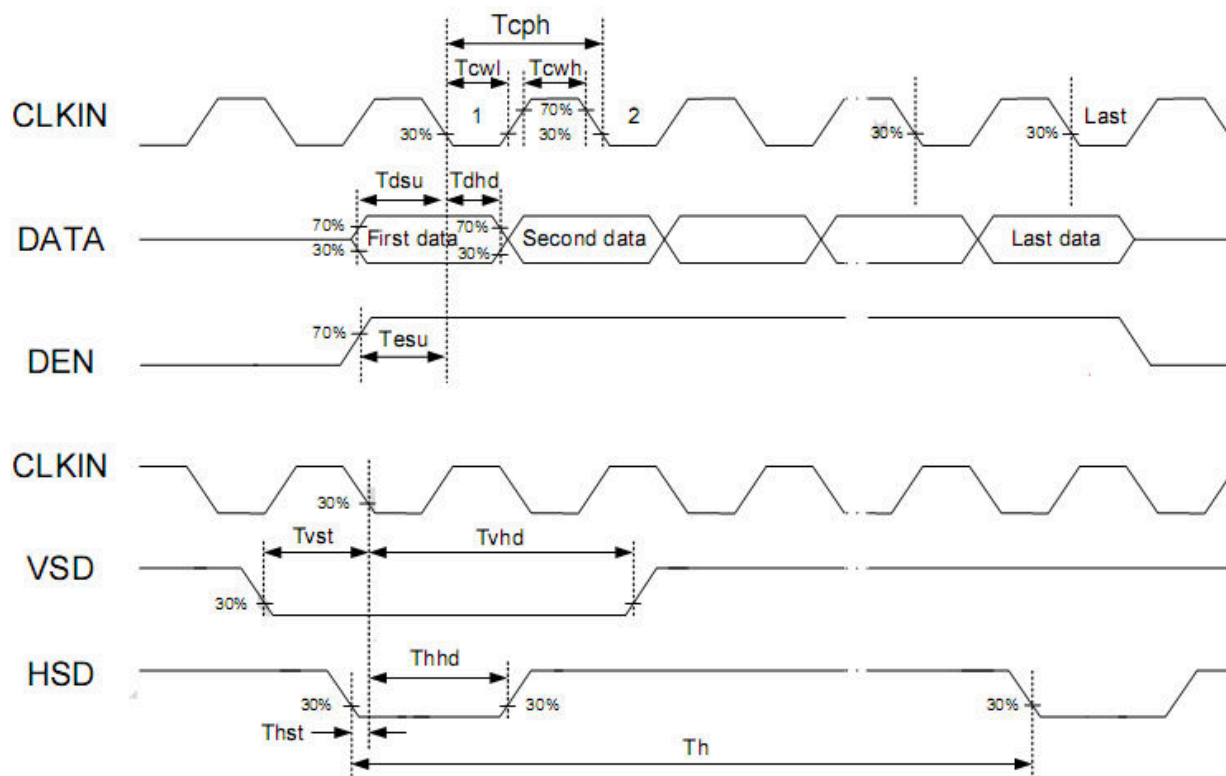

10.3.Data Input Format

Vertical Input Timing

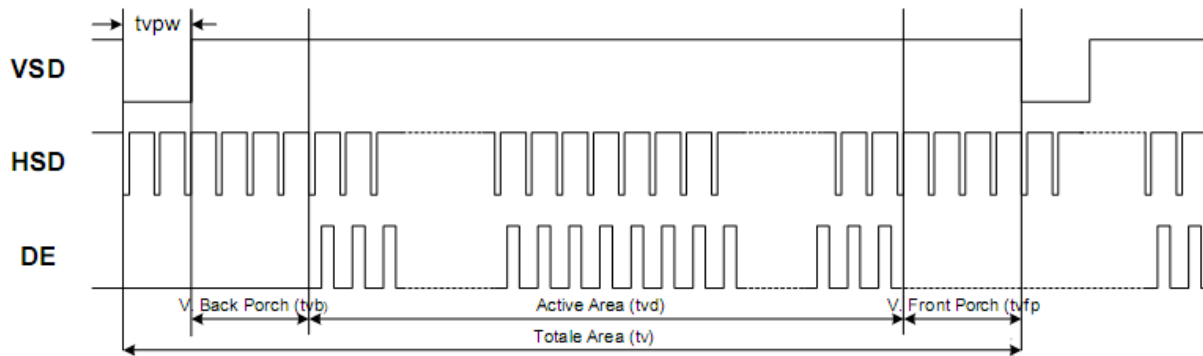

Horizontal Input Timing

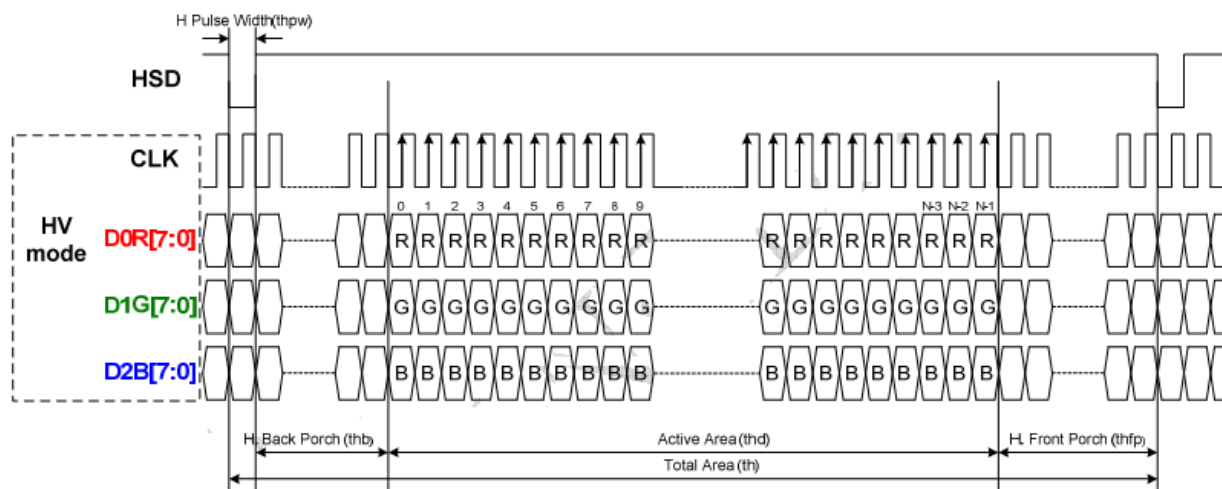

Timing Characteristics

Horizontal input timing

Parameter	Symbol	Value			Unit	Note
		Min.	Typ.	Max.		
Horizontal display area	thd	800			DCLK	
DCLK frequency	fclk	-	33.3	50	MHz	
1 Horizontal Line	th	908	928	1010	DCLK	thb+thpw=88 DCLK is fixed.
HSD pulse width	thpw	4	48	64		
HSD Back Porch (Blanking)	thb	20	40	84		
HSD Front Porch	thfp	20	40	122		

Vertical input timing

Parameter	Symbol	Value			Unit	Note
		Min.	Typ.	Max.		
Vertical display area	tvd	480			H	
VSD period time	tv	515	525	-	H	
VSD pulse width	tpw	1	3	31	H	tpw+tvb=32H is fixed
VSD Back Porch (Blanking)	tvb	1	29	31	H	
VSD Front Porch	tvfp	3	13	-	H	

11. Quality Assurance

11.1. Purpose

This standard for Quality Assurance assures the quality of LCD module products supplied to customer.

11.2. Standard for Quality Test

11.2.1 Sampling Plan:

GB2828.1-2012

Single sampling, general inspection level II

11.2.2 Sampling Criteria:

Visual inspection: AQL 1.5%

Electrical functional: AQL 0.65%.

11.2.3 Reliability Test:

Detailed requirement refer to Reliability Test Specification.

11.3. Nonconforming Analysis & Disposition

11.3.1 Nonconforming analysis:

11.3.1.1 Customer should provide overall information of non-conforming sample for their complaints.

11.3.1.2 After receipt of detailed information from customer, the analysis of nonconforming parts usually should be finished in one week.

11.3.1.3 If can not finish the analysis on time, customer will be notified with the progress status.

11.3.2 Disposition of nonconforming:

11.3.2.1 Non-conforming product over PPM level will be replaced.

11.3.2.2 The cause of non-conformance will be analyzed. Corrective action will be discussed and implemented.

11.4. Agreement Items

Shall negotiate with customer if the following situation occurs:

11.4.1 There is any discrepancy in standard of quality assurance.

11.4.2 Additional requirement to be added in product specification.

11.4.3 Any other special problem.

11.5. Standard of the Product Visual Inspection

11.5.1 Appearance inspection:

11.5.1.1 The inspection must be under illumination about 1000 – 1500 lx, and the distance of view must be at 30cm ± 2cm.

11.5.1.2 The viewing angle should be 45° from the vertical line without reflection light or follows customer's viewing angle specifications.

11.5.1.3 Definition of area: A Zone: Active Area, B Zone: Viewing Area,

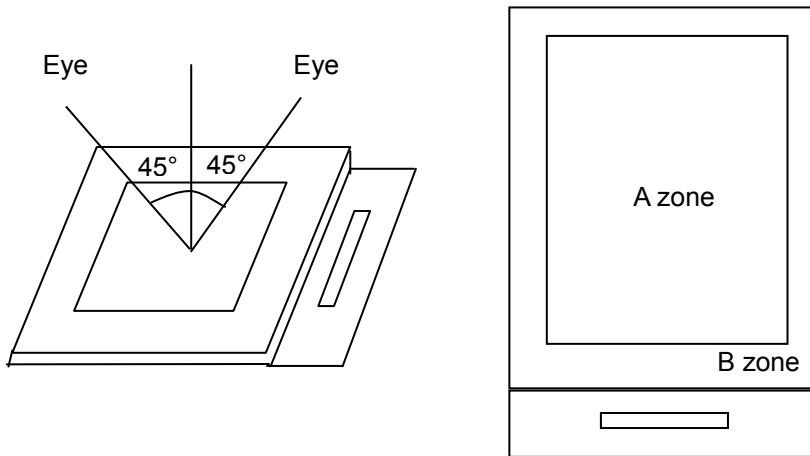

11.5.2 Basic principle:

11.5.2.1 A set of sample to indicate the limit of acceptable quality level must be discussed by both us and customer when there is any dispute happened.

11.5.2.2 New item must be added on time when it is necessary.

11.6. Inspection Specification

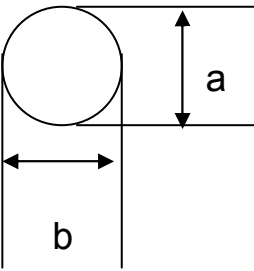
No.	Item	Criteria (Unit: mm)																	
01	Black / White spot Foreign material (Round type) Pinholes Stain Particles inside cell. (Minor defect)	 $\phi = (a + b) / 2$ Distance between 2 defects should more than 5mm apart.	<table border="1"> <thead> <tr> <th>Size</th> <th>Area</th> <th>Acc. Qty</th> </tr> </thead> <tbody> <tr> <td>$\phi \leq 0.20$</td> <td></td> <td>Ignore</td> </tr> <tr> <td>$0.20 < \phi \leq 0.50$</td> <td></td> <td>$N \leq 3$</td> </tr> <tr> <td>$0.50 < \phi$</td> <td></td> <td>0</td> </tr> </tbody> </table>	Size	Area	Acc. Qty	$\phi \leq 0.20$		Ignore	$0.20 < \phi \leq 0.50$		$N \leq 3$	$0.50 < \phi$		0				
Size	Area	Acc. Qty																	
$\phi \leq 0.20$		Ignore																	
$0.20 < \phi \leq 0.50$		$N \leq 3$																	
$0.50 < \phi$		0																	
02	Electrical Defect (Minor defect)	<table border="1"> <thead> <tr> <th rowspan="3">Bright dot</th> <th>Display Area</th> <th>Total</th> <th rowspan="3">Note1</th> </tr> </thead> <tbody> <tr> <td>$N \leq 2$</td> <td>$N \leq 2$</td> </tr> <tr> <th>Dark dot</th> <td>$N \leq 4$</td> <td>$N \leq 4$</td> </tr> <tr> <th>Total dot</th> <td>$N \leq 4$</td> <td>$N \leq 4$</td> </tr> <tr> <th>Mura</th> <td colspan="2">Not visible through 5% ND filters.</td> <th>Note2</th> </tr> </tbody> </table> <p>Remark: 1. Bright dot caused by scratch and foreign object accords to item 1.</p>		Bright dot	Display Area	Total	Note1	$N \leq 2$	$N \leq 2$	Dark dot	$N \leq 4$	$N \leq 4$	Total dot	$N \leq 4$	$N \leq 4$	Mura	Not visible through 5% ND filters.		Note2
Bright dot	Display Area	Total	Note1																
	$N \leq 2$	$N \leq 2$																	
	Dark dot	$N \leq 4$		$N \leq 4$															
Total dot	$N \leq 4$	$N \leq 4$																	
Mura	Not visible through 5% ND filters.		Note2																

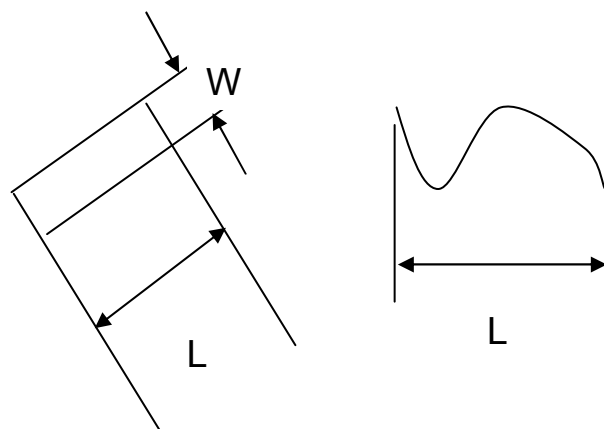
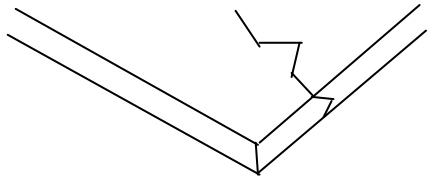
<p>03</p>	<p>Black and White line Scratch Foreign material (Line type) (Minor defect)</p>	 <table border="1" data-bbox="598 705 1220 974"> <thead> <tr> <th>Length</th> <th>Width</th> <th>Acc. Qty</th> </tr> </thead> <tbody> <tr> <td>/</td> <td>$W \leq 0.1$</td> <td>Ignore</td> </tr> <tr> <td>$L \leq 2.5$</td> <td>$0.1 < W \leq 0.2$</td> <td>3</td> </tr> <tr> <td>$L > 2.5$</td> <td>$0.2 < W$</td> <td>0</td> </tr> <tr> <td colspan="2">Total</td> <td>3</td> </tr> </tbody> </table> <p>Distance between 2 defects should more than 3mm apart. Scratches not viewable through the back of the display are acceptable.</p>	Length	Width	Acc. Qty	/	$W \leq 0.1$	Ignore	$L \leq 2.5$	$0.1 < W \leq 0.2$	3	$L > 2.5$	$0.2 < W$	0	Total		3
Length	Width	Acc. Qty															
/	$W \leq 0.1$	Ignore															
$L \leq 2.5$	$0.1 < W \leq 0.2$	3															
$L > 2.5$	$0.2 < W$	0															
Total		3															
<p>04</p>	<p>Glass Crack (Minor defect)</p>	 <p>Crack is potential to enlarge, any type is not allowed.</p>															

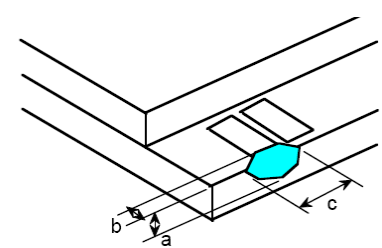
<p>05</p>	<p>Glass Chipping Pad Area: (Minor defect)</p> 	<table border="1" data-bbox="861 1724 1332 1904"> <thead> <tr> <th>Length and Width</th> <th>Acc. Qty</th> </tr> </thead> <tbody> <tr> <td>$c > 3.0, b < 1.0$</td> <td>1</td> </tr> <tr> <td>$c < 3.0, b < 1.0$</td> <td>3</td> </tr> <tr> <td colspan="2">$a < \text{Glass Thickness}$</td> </tr> </tbody> </table>	Length and Width	Acc. Qty	$c > 3.0, b < 1.0$	1	$c < 3.0, b < 1.0$	3	$a < \text{Glass Thickness}$	
Length and Width	Acc. Qty									
$c > 3.0, b < 1.0$	1									
$c < 3.0, b < 1.0$	3									
$a < \text{Glass Thickness}$										

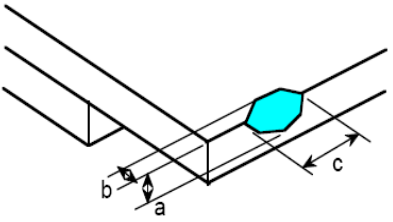
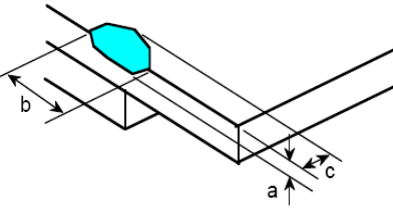
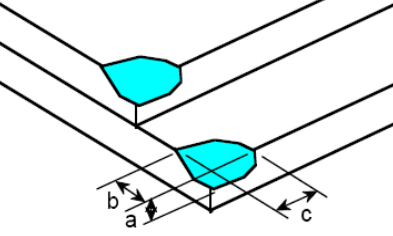
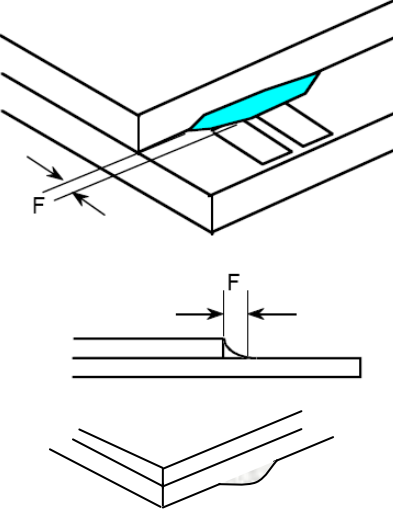
<p>06</p>	<p>Glass Chipping Rear of Pad Area: (Minor defect)</p> 	<table border="1"> <thead> <tr> <th>Length and Width</th> <th>Acc. Qty</th> </tr> </thead> <tbody> <tr> <td>$c > 3.0, b < 1.0$</td> <td>1</td> </tr> <tr> <td>$c < 3.0, b < 1.0$</td> <td>2</td> </tr> <tr> <td>$c < 3.0, b < 0.5$</td> <td>4</td> </tr> <tr> <td colspan="2" style="text-align: center;">$a < \text{Glass Thickness}$</td> </tr> </tbody> </table>	Length and Width	Acc. Qty	$c > 3.0, b < 1.0$	1	$c < 3.0, b < 1.0$	2	$c < 3.0, b < 0.5$	4	$a < \text{Glass Thickness}$	
Length and Width	Acc. Qty											
$c > 3.0, b < 1.0$	1											
$c < 3.0, b < 1.0$	2											
$c < 3.0, b < 0.5$	4											
$a < \text{Glass Thickness}$												
<p>07</p>	<p>Glass Chipping Except Pad Area: (Minor defect)</p> 	<table border="1"> <thead> <tr> <th>Length and Width</th> <th>Acc. Qty</th> </tr> </thead> <tbody> <tr> <td>$c > 3.0, b < 1.0$</td> <td>1</td> </tr> <tr> <td>$c < 3.0, b < 1.0$</td> <td>2</td> </tr> <tr> <td>$c < 3.0, b < 0.5$</td> <td>4</td> </tr> <tr> <td colspan="2" style="text-align: center;">$a < \text{Glass Thickness}$</td> </tr> </tbody> </table>	Length and Width	Acc. Qty	$c > 3.0, b < 1.0$	1	$c < 3.0, b < 1.0$	2	$c < 3.0, b < 0.5$	4	$a < \text{Glass Thickness}$	
Length and Width	Acc. Qty											
$c > 3.0, b < 1.0$	1											
$c < 3.0, b < 1.0$	2											
$c < 3.0, b < 0.5$	4											
$a < \text{Glass Thickness}$												
<p>08</p>	<p>Glass Corner Chipping: (Minor defect)</p> 	<table border="1"> <thead> <tr> <th>Length and Width</th> <th>Acc. Qty</th> </tr> </thead> <tbody> <tr> <td>$c < 3.0, b < 3.0$</td> <td>Ignore</td> </tr> <tr> <td colspan="2" style="text-align: center;">$a < \text{Glass Thickness}$</td> </tr> </tbody> </table>	Length and Width	Acc. Qty	$c < 3.0, b < 3.0$	Ignore	$a < \text{Glass Thickness}$					
Length and Width	Acc. Qty											
$c < 3.0, b < 3.0$	Ignore											
$a < \text{Glass Thickness}$												
<p>09</p>	<p>Glass Burr: (Minor defect)</p> 	<table border="1"> <thead> <tr> <th>Length</th> <th>Acc. Qty</th> </tr> </thead> <tbody> <tr> <td>$F < 1.0$</td> <td>Ignore</td> </tr> </tbody> </table> <p>Glass burr don't affect assemble and module dimension.</p>	Length	Acc. Qty	$F < 1.0$	Ignore						
Length	Acc. Qty											
$F < 1.0$	Ignore											

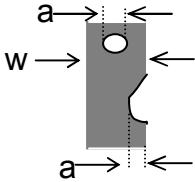
10	<p>FPC Defect: (Minor defect)</p> 	<p>10.1 Dent, pinhole width $a < w/3$. (w: circuitry width.) 10.2 Open circuit is unacceptable. 10.3 No oxidation, contamination and distortion.</p>								
11	Bubble on Polarizer (Minor defect)	<table border="1" data-bbox="743 577 1214 748"> <thead> <tr> <th>Diameter</th> <th>Acc. Qty</th> </tr> </thead> <tbody> <tr> <td>$\phi \leq 0.30$</td> <td>Ignore</td> </tr> <tr> <td>$0.30 < \phi \leq 0.50$</td> <td>$N \leq 2$</td> </tr> <tr> <td>$0.50 < \phi$</td> <td>$N = 0$</td> </tr> </tbody> </table>	Diameter	Acc. Qty	$\phi \leq 0.30$	Ignore	$0.30 < \phi \leq 0.50$	$N \leq 2$	$0.50 < \phi$	$N = 0$
Diameter	Acc. Qty									
$\phi \leq 0.30$	Ignore									
$0.30 < \phi \leq 0.50$	$N \leq 2$									
$0.50 < \phi$	$N = 0$									
12	Dent on Polarizer (Minor defect)	<table border="1" data-bbox="743 801 1214 972"> <thead> <tr> <th>Diameter</th> <th>Acc. Qty</th> </tr> </thead> <tbody> <tr> <td>$\phi \leq 0.25$</td> <td>Ignore</td> </tr> <tr> <td>$0.25 < \phi \leq 0.50$</td> <td>$N \leq 4$</td> </tr> <tr> <td>$0.50 < \phi$</td> <td>None</td> </tr> </tbody> </table>	Diameter	Acc. Qty	$\phi \leq 0.25$	Ignore	$0.25 < \phi \leq 0.50$	$N \leq 4$	$0.50 < \phi$	None
Diameter	Acc. Qty									
$\phi \leq 0.25$	Ignore									
$0.25 < \phi \leq 0.50$	$N \leq 4$									
$0.50 < \phi$	None									
13	Bezel	<p>13.1 No rust, distortion on the Bezel. 13.2 No visible fingerprints, stains or other contamination.</p>								
14	Touch Panel	<p>D: Diameter W: width L: length 14.1 Spot: $D < 0.25$ is acceptable $0.25 \leq D \leq 0.4$ 2dots are acceptable and the distance between defects should more than 10 mm. $D > 0.4$ is unacceptable 14.2 Dent: $D > 0.40$ is unacceptable 14.3 Scratch: $W \leq 0.03$, $L \leq 10$ is acceptable, $0.03 < W \leq 0.10$, $L \leq 10$ is acceptable Distance between 2 defects should more than 10 mm. $W > 0.10$ is unacceptable.</p>								
15	LCD Ripple	<p>Touch the touch panel, cannot see the LCD ripple. Pen: R 0.8mm silicon rubber. Operation Force:100g</p>								
16	PCB	<p>16.1 No distortion or contamination on PCB terminals. 16.2 All components on PCB must same as documented on the BOM/component layout. 16.3 Follow IPC-A-600F.</p>								
17	Soldering	Follow IPC-A-610C standard								

18	Electrical Defect (Major defect)	<p>The below defects must be rejected.</p> <p>18.1 Missing vertical / horizontal segment, 18.2 Abnormal Display. 18.3 No function or no display. 18.4 Current exceeds product specifications. 18.5 LCD viewing angle defect. 18.6 No Backlight. 18.7 Dark Backlight. 18.8 Touch Panel no function.</p>
----	-------------------------------------	------------------------------------------------------------------------------------------------------------------------------------------------------------------------------------------------------------------------------------------------------------------------------------------------------------------------------------

Remark: LCD Panel Broken shall be rejected. Defect out of LCD viewing area is acceptable.

11.7. Classification of Defects

11.7.1 Visual defects (Except no / wrong label) are treated as minor defect and electrical defect is major.

11.7.2 Two minor defects are equal to one major in lot sampling inspection.

11.8. Identification/marketing criteria

Any unit with illegible / wrong /double or no marking/ label shall be rejected.

11.9. Packaging

11.9.1 There should be no damage of the outside carton box, each packaging box should have one identical label.

11.9.2 Modules inside package box should have compliant mark.

11.9.3 All direct package materials shall offer ESD protection

Note1: Bright dot is defined as the defective area of the dot is larger than 50% of one sub-pixel area.

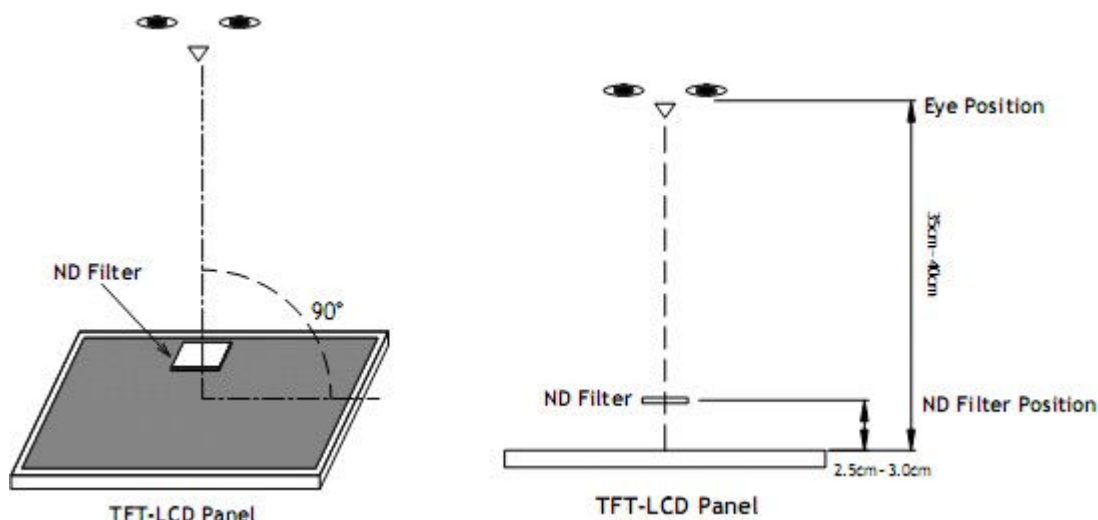

Bright dot: The bright dot size defect at black display pattern. It can be recognized by 2% transparency of filter when the distance between eyes and panel is $350\text{mm} \pm 50\text{mm}$.

Dark dot: Cyan, Magenta or Yellow dot size defect at white display pattern. It can be recognized by 5% transparency of filter when the distance between eyes and panel is $350\text{mm} \pm 50\text{mm}$.

Note2: Mura on display which appears darker / brighter against background brightness on parts of display area.

12. Reliability Specification

No	Item	Condition	Quantity	Criteria
1	High Temperature Operating	70°C, 96Hrs	2	GB/T2423.2-2008
2	Low Temperature Operating	-20°C, 96Hrs	2	GB/T2423.1-2008
3	High Humidity	50°C, 90%RH, 96Hrs	2	GB/T2423.3-2006
4	High Temperature Storage	80°C, 96Hrs	2	GB/T2423.2-2008
5	Low Temperature Storage	-30°C, 96Hrs	2	GB/T2423.1-2008
6	Thermal Cycling Test	-20°C, 60min~70°C, 60min, 20 cycles.	2	GB/T2423.22-2012
7	Packing vibration	Frequency range:10Hz~50Hz Acceleration of gravity:5G X, Y, Z 30 min for each direction.	2	GB/T5170.14-2009
8	Electrical Static Discharge	Air: ±8KV 150pF/330 Ω 5 times Contact: ±4KV 150pF/330 Ω 5 times	2	GB/T17626.2-2006
9	Drop Test (Packaged)	Height:80 cm,1 corner, 3 edges, 6 surfaces.	2	GB/T2423.8-1995

Note1. No deflection cosmetic and operational function allowable.

Note2. Total current Consumption should be below double of initial value

13. Precautions and Warranty

13.1. Safety

13.1.1 The liquid crystal in the LCD is poisonous. Do not put it in your mouth. If the liquid crystal touches your skin or clothes, wash it off immediately using soap and water.

13.1.2 Since the liquid crystal cells are made of glass, do not apply strong impact on them. Handle with care.

13.2. Handling

13.2.1 Reverse and use within ratings in order to keep performance and prevent damage.

13.2.2 Do not wipe the polarizer with dry cloth, as it might cause scratch. If the surface of the LCD needs to be cleaned, wipe it swiftly with cotton or other soft cloth soaked with petroleum IPA, do not use other chemicals.

13.3. Storage

13.3.1. Do not store the LCD module beyond the specified temperature ranges.

13.3.2. Strong light exposure causes degradation of polarizer and color filter

13.4. Metal Pin (Apply to Products with Metal Pins)

13.4.1 Pins of LCD and Backlight

13.4.1.1 Solder tip can touch and press on the tip of Pin LEAD during the soldering

13.4.1.2 Recommended Soldering Conditions

Solder Type: Sn96.3~94-Ag3.3~4.3-Cu0.4~1.1

Maximum Solder Temperature: 370℃

Maximum Solder Time: 3s at the maximum temperature

Recommended Soldering Temp: 350±20℃

Typical Soldering Time: ≤3s

13.4.1.3 Solder Wetting

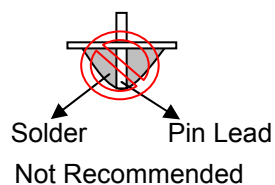
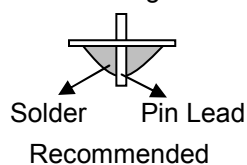

13.4.2 Pins of EL

13.4.2.1 Solder tip can touch and press on the tip of EL leads during soldering.

13.4.2.2 No Solder Paste on the soldering pad on the motherboard is recommended.

13.4.2.3 Recommended Soldering Conditions

Solder type: Nippon Alimit Leadfree SR-34, size 0.5mm

Recommended Solder Temperature: 270~290℃

Typical Soldering Time: ≤2s

Minimum solder distance from EL lamp (body):2.0mm

13.4.2.4 No horizontal press on the EL leads during soldering.

13.4.2.5 180° bend EL leads three times is not allowed.

13.4.2.6 Solder Wetting

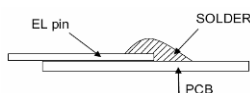

Recommended



Not Recommended

13.4.2.7 The type of the solder iron:

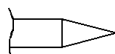

Recommended

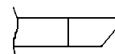

Not Recommended

13.4.2.8 Solder Pad

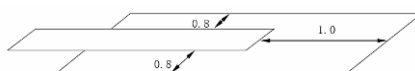

13.5. Operation

- 13.5.1. Do not drive LCD with DC voltage
- 13.5.2. Response time will increase below lower temperature
- 13.5.3. Display may change color with different temperature
- 13.5.4. Mechanical disturbance during operation, such as pressing on the display area, may cause the segments to appear "fractured".
- 13.5.5. Do not connect or disconnect the LCM to or from the system when power is on.
- 13.5.6. Never use the LCM under abnormal condition of high temperature and high humidity.
- 13.5.7. Module has high frequency circuits. Sufficient suppression to the electromagnetic interface shall be done by system manufacturers. Grounding and shielding methods may be important to minimize the interference.
- 13.5.8. Do not display the fixed pattern for long time (we suggest the time not longer than one hour) because it may develop image sticking due to the TFT structure.

13.6. Static Electricity

- 13.6.1. CMOS LSIs are equipped in this unit, so care must be taken to avoid the electro-static charge, by ground human body, etc.
- 13.6.2. The normal static prevention measures should be observed for work clothes and benches.
- 13.6.3. The module should be kept into anti-static bags or other containers resistant to static for storage.

13.7. Limited Warranty

- 13.7.1 Our warranty liability is limited to repair and/or replacement. We will not be responsible for any consequential loss.
- 13.7.2 If possible, we suggest customer to use up all modules in six months. If the module storage time over twelve months, we suggest that recheck it before the module be used.
- 13.7.3 After the product shipped, any product quality issues must be feedback within three months, otherwise, we will not be responsible for the subsequent or consequential events.

14. Packaging

TBD

15. Outline Drawing

